

# **TM 11-5820-357-35**

**DEPARTMENT OF THE ARMY TECHNICAL MANUAL**

---

## **FIELD AND DEPOT MAINTENANCE MANUAL**

### **RADIO RECEIVER R-390/URR**

---

This copy is a reprint which includes  
current pages from Changes 1 and 2.

**HEADQUARTERS DEPARTMENT OF THE ARMY  
9 MARCH 1962**

## **WARNING**

### **DANGEROUS VOLTAGES EXIST IN THIS EQUIPMENT**

Be careful when working on the plate power circuits or on the 115/230-volt ac line connections.

### **DON'T TAKE CHANCES!**

## **WARNING**

When selenium rectifiers fail, because of burn-out or arc-over, poisonous fumes and compounds are released. The fumes have a strong odor; they should not be inhaled. *Provide adequate ventilation immediately; do not handle the rectifier until it has cooled.* Rectifier CR801 in Power Supply PP-621/URR is a selenium rectifier.

## Field and Depot Maintenance Manual

## RADIO RECEIVER R-390/URR

TM 11-5820-357-35

DEPARTMENT OF THE ARMY

WASHINGTON, D. C., 1 January 1989

TM 11-5820-357-35, 9 March 1962 is changed as follows:

Page 131, paragraph 101i. -50 volts  
is changed to read -5 volts

Page 131. Paragraph 101j is superseded as follows:

j. Increase Signal Generator Output above the reference level by amount indicated on table and then detune the Signal Generator until the diode load voltage again reads (-5) volts. The Bandwidth shall be -IT the specified amount.

BANDWIDTH Switch (kc)	Specific standard (DB)	Deviation (not more than)(kc)
1	6	1.5
1	20	3.0
1	40	5.0
16	6	16.0
16	20	19.0
16	40	24.0

Page 135, paragraph 114i. 300 times is changed to read 6 times.

By Order of the Secretary of the Army:

CARL E. VUONO  
*General, United States Army*  
*Chief of Staff*

Official:

WILLIAM J. MEEHAN II  
*Brigadier General, United States Army*  
*The Adjutant General*

**DISTRIBUTION:**

To be distributed in accordance with DA Form 12-51 DS/GS requirements for R-390/URR.

Field and Depot Maintenance Manual

RADIO RECEIVER 51-390/URR

TM 11-5820-357-35  
TO 31R2-2URR-412

DEPARTMENTS OF THE ARMY  
AND THE AIR FORCE  
WASHINGTON 25, D.C., 25 October 1962

TM 11-5820-357-35 9 March 1962, is changed as follows:

Add the following caution in the places listed below:

*Caution:* To prevent damage to the receiver be sure to turn the DIAL LOCK control clockwise until it stops before turning the KILOCYCLE CHANGE control. Do not force the DIAL LOCK control beyond its normal stops in either direction.

Page 38. After chapter heading.

Page 77. After chapter heading.

Page 101, paragraph 87c, before chart.

Page 130. After chapter heading.

Page 67, after paragraph 58b(5). Insert the following:

*Caution:* When turning the ZERO ADJ knob, do not force the control beyond its stops. The shaft can be turned to a point at which its end plate is forced off.

Page 75, paragraph 71. Add paragraph 71.1 after paragraph 71.

#### 71.1. Adjustment of ZERO ADJ Control

Check the adjustment of the ZERO ADJ control as follows:

*Caution:* When turning the ZERO ADJ control do not force the control beyond its stop. The shaft can be turned to a point at which its end plate is

forced off.

a. Turn the ZERO ADJ control fully counterclockwise. Slowly turn the control clockwise and observe the free play. The free play should be approximately 1/8 turn (par. 58b(6)).

b. If there is no free play or if it is excessive, remove the knob.

c. With the thumb and forefinger, adjust the shaft for approximately 1/8-turn free play

d. Replace the knob so that the stop on the rear of the knob is directly to the right of, and touching the finger on, the ZERO ADJ control locking washer on the front panel. Tighten the knob.

e. Turn the ZERO ADJ control fully clockwise to the stop, and check to see that the clutch gear (fig. 43) is disengaged. Do this by rocking the KILOCYCLE CHANGE control back and forth while observing the reading of the frequency indicator to see that it does not change

f. Turn the ZERO ADJ control fully counterclockwise to the stop and recheck for approximately 1/8-turn free play.

g. Repeat the procedures given in b through f above if the free play and clutch disengagement are not as specified.

By Order of the Secretaries of the Army and the Air Force:

Official:

J. C. LAMBERT,  
Major General, United States Army,  
The Adjutant General

EARLE G. WHEELER,  
General, United States Army,  
Chief of Staff.

Official:

R. J. PUGH,  
Colonel, United States Air Force,  
Director of Administrative Services.

CURTIS E. LEMAY,  
Chief of Staff,  
United States Air Force.

Distribution:

Active Army:

- DASA (6)
- USASA (2)
- CNGB (1)
- CSigO (5)
- CofEngrs (1)
- CofT (1)
- TSG (1)
- USA Engr CD Agcy (1)
- USA CBR CD Agcy (1)
- USA Comm Elct CD Agcy (1)
- USA Med Svc CD Agcy (1)
- USA Orb CD Agcy (1)
- USA QM CD Agcy (1)
- USA Trans CD Agcy (1)
- USA AD CD Agcy (2)
- USA Armor CD Agcy (2)
- USA Arty CD Agcy (1)
- USA Inf CD Agcy (1)
- USA Intel CD Agcy (1)
- USA Avn CD Agcy (1)
- USA SPWAR CD Agcy (1)
- USAATBD (1)
- ARADCOM (2)
- ARADCOM Rgn (2)
- OS Maj Comd (8)
- OS Base Comd (2)
- LOGCOMD (2)
- MDW (1)
- Armies (2)
- Corps (2)
- Instl. (2) except  
Ft Monmouth (68)
- USATC AD (2)
- USATC Engr (2)
- USATC Inf (2)
- USATC FA (2)
- USATC Armor (2)

- Svc Colleges (2)
- Br Svc Sch (2) except  
USASCS (100)
- USMA (2)
- GENDEP (OS) (2)
- Sig Sec. GENDEP (OS) (5)
- A Dep (2) except  
Atlanta (None)
- Dep (OS) (2)
- Sig Fld Maint Shops (3)
- USAOMC (4)
- WRAMC (1)
- USA Trans Tml Comd (1)
- Army Tml (1)
- OSA (1)
- POE (1)
- USAEPPG (2)
- AFIP (1)
- AMS (1)
- Army Pictorial Cen (2)
- EMC (1)
- Yuma Test Sta (2)
- USASSA (26)
- USA Carib Sig Agcy (1)
- USA Sig Msl Spt Agcy (13)
- Def Log Svc Can (1)
- QMRECOMD (2)
- USA Strat Comm Comd (4)
- USA Corps (8)
- JBUSMC (2)
- Units org under fol TOE:  
(2 copies each except as indicated)
- 11-7      11-117      11-587
- 11-16      11-1U      11-592
- 11-57      11-167      11-597
- 11-85      11-500 (AA-AE) (4)
- 11-98      11-557

NG: State AG (8); units-army as active army except allowance is one copy to

USAR: None .

For explanation of abbreviations sec AR 820-50

Technical Manual

HEADQUARTERS,  
DEPARTMENT OF THE ARMY  
WASHINGTON 25, D. C., 9 MARCH 1962

No. 11-5820-357-35

**RADIO RECEIVER R-390/URR**

		Paragraph	Page
CHAPTER 1.	Theory		
Section	I. General.....	1,2	3
	II. Theory of Radio receiver R-390/URR.....	3-30	4-30
	III. Theory of Power Supply PP-621/URR, voltage regulator, filament circuits, and oven heater circuits.....	31-37	30-35
	IV. Analysis of mechanical tuning system.....	38-40	35-37
CHAPTER 2.	THIRD ECHELON MAINTENANCE		
Section	I. General troubleshooting techniques.....	41-43	38
	II. Troubleshooting receiver.....	44-55	39-65
	III. Repairs .....	56-71	66-72
	IV. Adjustments.....	68-71	74,75
Chapter	3. FOURTH ECHELONS MAINTENANCE		
Section	I. Repairs and adjustments.....	72-74	77-90
	II. Alignment .....	75-82	91-98
	III. Testing procedures.....	83-93	98-123
Chapter	4. DEPOT INSPECTION PROCEDURES		
Section	I. Preparation.....	99-98	130
	II. Tests.....	99-116	131-135
APPENDIX.	REFERENCES .....		137
INDEX.....			165

---

\*This manual, together with TM 11-5820-357-10, 29 December 1960 and TM 11-5820-357-20, 23 March 1961 supersedes TM 11-856, 11 January 1955 including C1, 23 June 1955; C2, 29 September 1955; C3, 19 January 1956; C4, 22 December 1958; and C5. 31 December 1959.

# CHAPTER 1

## THEORY

### Section I. GENERAL

#### 1. Scope

a. This manual covers field and depot maintenance for Radio Receiver R-390/URR. It includes instructions appropriate to third, fourth and fifth echelons for troubleshooting, testing, aligning, and repairing the equipment, and replacing maintenance parts. It also lists tools, materials, and test equipment for third, fourth, and fifth echelon maintenance. Detailed functions of the equipment are covered in the theory sections.

b. The complete technical manual for this equipment includes seven other publications (appx I).

c. Refer to DA Pamphlet 310-4 to determine what changes to or revisions of the publication are current.

d. Forward comments concerning this manual to the Commanding Officer, U. S. Army Signal Materiel Support Agency, ATTN: SIGMS-PA2d, Fort Monmouth, N. J.

Note: For applicable forms and records see paragraph 2, TM 11-5820-257-10.

#### 2. Internal Differences in Models

During production, modifications were made to the receiver. When these modifications were performed, the subchassis affected were stamped with a

modification (MOD) number.

a. *Changes to Rf Gear Train.* In unmodified radio frequency (rf) gear trains, the green coded offset gear has the green face to ward the rear of the receiver and is not meshed with the clutch gear. In gear trains stamped MOD 1, the green face is mounted toward the front of the receiver and is meshed with the clutch gear.

b. *Changes to Variable Frequency Oscillator Subchassis.* Refer to figure 5 for differences between unmodified variable frequency oscillator subchassis and those bearing MOD number 1.

c. *Changes to Rf Tuning Coils and Transformers.* Beginning with rf subchassis MOD 2, the cores of antenna coils T201 through T206 are made of different material to improve tracking. The cores on tuning circuits Z206, Z212, and Z218 are smaller in size to increase the tuning range of the high-frequency band. Coils or transformers that have identical functions are interchangeable for all models, providing that the change is made complete with tuning cores. When a tuning core alone is replaced, the correct one of the two types available must be selected for proper operation of the coil.

d. *Other Differences.* Other changes to the receiver during production are listed in the chart below.

Item	Subchassis	No MOD	MOD 1	MOD 2	MOD 3	MOD 4
R609, between junction of R604 and R608	Af.	18 ohms	18 ohms	Not used	Not used	Not used
R558	If.	1 megohm	1.2 megohms	1.2 megohms	1.2 megohms	1.2 megohms
C246	Crystal oscillator	130 uuf	120 uuf	120 uuf	120 uuf	120 uuf
C439	Crystal oscillator	Not used	Not used	5, 000 uuf	5, 000 uuf	5, 000 uuf
C440	Crystal oscillator	Not used	Not used	5, 000 uuf	5, 000 uuf	5, 000 uuf
C905	Crystal oscillator	150 uuf	200 uuf	200 uuf	200 uuf	200 uuf
C914	Crystal oscillator	Not used	0.01 uf	0.01 uf	0.01 uf	0.01 uf

Item	Subchassis	No MOD	MOD 1	MOD 2	MOD 3	MOD 4
L903	Calibration oscillator	Not used	0.5 mh	0.5 mh	0.5 mh	0.5 mh
R221	Rf	27 ohms	68 ohms	68 ohms	68 ohms	68 ohms
C307	Rf	1 uuf	1 uuf	0.75 uuf	0.75 uuf	0.75 uuf
C310	Rf	1 uuf	1 uuf	0.75 uuf	0.75 uuf	0.75 uuf
C207	Rf	22 uuf	22 uuf	150 uuf	150 uuf	150 uuf
C248	Rf	24 uuf	24 uuf	75 uuf	75 uuf	75 uuf
C271	Rf	24 uuf	24 uuf	27 uuf	27 uuf	27 uuf
C302	Rf	24 uuf	24 uuf	27 uuf	27 uuf	27 uuf
C249	Rf	56 uuf	56 uuf	51 uuf	51 uuf	51 uuf
C279	Rf	56 uuf	56 uuf	180 uuf	180 uuf	180 uuf
C303	Rf	56 uuf	56 uuf	51 uuf	51 uuf	51 uuf
C274	Rf	510 uuf	510 uuf	330 uuf	330 uuf	330 uuf
C289	Rf	68uuf	68uuf	39 uuf	39 uuf	39 uuf
R203	Rf	100 ohms	100 ohms	220 ohms	220 ohms	220 ohms
C221B connected between	Rf	Terminals 3 and 5 of T206	Terminals 3 and 5 of T206	Terminals 3 and 5 of T206	Terminals 3 and 5 of T206	Terminals 3 and 5 of T206
C242	Rf	Not used	Not used	24 uuf	24 uuf	24 uuf
C343	Rf	Not used	Not used	Not used	2,000 uuf	2,000 uuf
C344	Rf	Not used	Not used	Not used	Not used	5,000 uuf
R635	Af	Not used	27 ohms	27 ohms	27 ohms	27 ohms
C612	Af	Not used	Not used	8 uf	8 uf	8 uf

## Section II. THEORY OF RADIO RECEIVER R-390/URR

### 3. Block Diagram

(fig. 56)

Radio Receiver R-390/URR provides for the reception of voice, continuous wave (cw), single-sideband (ssb), and frequency-shift signals over a frequency range of 0.5 to 32 megacycles (mc). The receiver is a super-heterodyne of the multiple-conversion type. Triple conversion is used for the lower frequencies (0.5 to 8 mc), and double conversion is used for the higher frequencies (8 to 32 mc). The block diagram shows each stage from antenna input to audio frequency (af) and intermediate frequency (if.) output. A schematic diagram (fig. 74) shows details of the circuits in the same order.

*a. Antenna Circuits.* Radio frequency signals are fed to the receiver from either a balanced or unbalanced antenna. If the balanced antenna input is used, the rf signals pass through one of several antenna transformers (selection of which is determined by the operating frequency of the receiver) and are fed to first rf amplifier V201. If the unbalanced antenna input is used, the signals are capacitor-coupled to the secondary of the antenna transformers and are applied to first rf amplifier

V201. Antenna relay K101 grounds the antenna input for break-in operation, during calibration and standby operation.

*b. Calibration Oscillator V901A, Multivibrator V902, and Buffer Amplifier V901B.* This circuit supplies a signal at every 100-kilocycle (kc) point within the frequency range of the receiver. The signal for synchronizing multi vibrator stage V902 at 100 kc is provided by 1,000-kc calibration-oscillator stage V901A. Buffer-amplifier stage V901B isolates the multivibrator from the loading effects of the rf circuit and increases the strength of the 100-kc harmonics. B+ voltage is fed to the calibration-oscillator circuits only when the FUNCTION switch is in the CAL position.

*c. Rf Amplifiers.* The output of first rf amplifier V201 is coupled to second rf amplifier V202. The gain of the first and second rf amplifiers is controlled manually by the RF GAIN control and automatically by the automatic gain control (age) voltage. The output of the second rf amplifier (0.5 to 32 mc) is fed to either the first or second mixer (V203 and V204), depending on the MEGACYCLE CHANGE control setting.

*d. Mixers.*

- (1) First mixer V203 receives heterodyning signals from the second rf amplifier and, in the range of 0.5 to 8 me, from first crystal oscillator V401. A variable if. signal is produced which has a range of 9 to 18 me.
- (2) (2)Second mixer V204 heterodynes the first variable if. signals ((1) above) and those in the range from 8 to 32 me from second crystal oscillator V402. The range of the second if. is from 3 to 2 me. This frequency decreases as the input signal frequency increases.
- (3) Third mixer V205 heterodynes the second variable if. signals ((2) above) and those in the range from 3.455 to 2.455 from variable frequency oscillator (vfo) V701. The resulting fixed if. output is always 455 kc.

*e. If Amplifiers.* The 455-kc output signal from the third mixer is applied to first if amplifier V501 either directly or through crystal filter Z501, depending on the bandwidth desired. For the 0.1- and 1-kc narrow bandpass positions, the crystal filter is used. Four additional degrees of selectivity that do not use the crystal filter are accomplished in the if. stages by the BANDWIDTH switch which varies the coupling between the primary and secondary circuits of the if. transformers. The if. amplifier consists of six stages, V501 through V506, which, with associated transformers, provide the required bandpass. The 455-kc output of V505 is applied to sixth if. amplifier V506, age amplifier V509, and cathode follower V511B. The output signal from the sixth if. amplifier is demodulated in detector circuit V507A. Provision is made on the rear panel for connecting an external diode load.

*f. Age Circuit.* With the FUNCTION switch set to AGC, the gain of rf amplifiers V201 and V202 and if. amplifiers V501 and V505 is automatically controlled by age rectifier V510A, which receives its signal from age amplifier V509. The response rate of the age circuits can be controlled by a three-position front-panel control which changes the time constant through tube V511B. For manual gain control (mgc) operation, the age bus is grounded by the FUNCTION switch.

*g. Cathode Follower.* Stage V511B provides a low-impedance connection (50 ohms) from the output of the fifth if. stage for use when the receiver is used for operation of frequency-shift teletypewriter or single-sideband converters.

*h. Beat-Frequency Oscillator.* For reception of radiotelegraph (cw) signals and calibration signals, beat-frequency oscillator (bfo) V508 provides a signal in the frequency range of 452 to 458 kc. The 455-kc if. output signal from the sixth if. amplifier is mixed with the bfo signal to produce an audible beat note in the detector output. The pitch of the beat note can be varied by a front-panel control. For receiving ssb signals, the bfo is used to replace the carrier that was suppressed at the transmitter.

*i. Detector.* The detector demodulates the 455-kc signal for the reception of voice and tone-modulated signals. For receiving cw signals, it heterodynes the 455-kc carrier signal and the output of the bfo to produce audible tones.

*j. Negative- an Positive-Peak Limiters.* The limiter circuits reduce noise in the receiver output. A front-panel control disables the limiter or provides different degrees of limiting. The negative-peak limiter is V507B; the positive-peak limiter is V510B.

*k. Af Amplifiers.* The output of the limiters is coupled to af amplifier V601, which amplifies the audio input and supplies audio signals to the local and line af amplifiers. The local af amplifier stages, V602A and V603, supply audio power to drive the headset and the loudspeaker. The line af amplifier stages, V602B and V604, supply audio power to a balanced line for remote listening. The inputs to these audio amplifiers are shorted to ground by squelch relay K601 (*l* below) and break-in relay K602 (*m* below) when these relays are actuated.

*l. Squelch Circuit.* With the FUNCTION switch set to SQUELCH, a signal is fed to squelch tube V601B from detector V507A. The output of the squelch tube varies in proportion to the average signal level. When the signal drops below a level predetermined by the RF GAIN control setting, squelch relay

K601 grounds the input to af amplifier V601.

*m. Break-In Relay.* When the receiver is used in conjunction with a radio transmitter, the receiver is usually wired for break-in operation. This means that the receiver is disabled while the transmitter is in operation. To disable the receiver, control circuits complete the circuit to break-in relay K602 to energize it and to close its contacts, thus grounding the output of af amplifier V601A. At the same time, antenna relay K101 is energized, closing its contacts and grounding both antenna input circuits.

*n. Power Supply PP-621/URR.* The PP-621/URR provides direct current (dc) for antenna and break-in relays, alternating current (ac) for the filament and oven circuits, and dc B+ voltage for the voltage regulator circuits. The voltage regulator circuits consist of series voltage regulators V605 and V606, tic amplifier V607, and voltage reference tubes V608 and V609. The PP-621/URR consists of a transformer and rectifiers V801 and V802. Voltage for the break-in relay circuits is provided by dry-disk rectifier CR801.

#### **4. Antenna Circuit (fig. 57)**

The antenna circuit matches antennas that have different characteristic impedance to the input of first rf amplifier V201.

*a.* Antennas that have a balanced, terminal impedance of 50 to 200 ohms and terminate in two conductor cables are connected through J108 to the primary winding of one of six antenna transformers. One lead is connected through J110, P210, and S202; the other lead is connected through J111, P211, and S201. Six transformers (T201 through T206) are used to cover the frequency range of 0.5 to 32 mc. The transformer in use is selected by the operation of switches S201 through S205. The operation is similar for all bands; therefore only the 0.5- to 1-me band is shown in figure 57. This type of coverage will be used in all succeeding stages unless otherwise indicated.

*b.* The primary winding of T201 is balanced to ground by fixed capacitor C202 and variable capacitor C201A. The secondary winding is shunted by variable capacitor C201B, fixed

capacitor C203, and ANT. TRIM capacitor C225. Transformer T201 contains an adjustable powdered-iron core. The KILOCYCLE CHANGE control moves this core and other tuning cores in the receiver.

*c.* The voltage developed across the secondary of T201 is applied through C227 to the control grid of first rf amplifier V201. When an unbalanced antenna, such as a whip, is used, the input to V201 is applied from J107 through J109 and P209, S204, C204, S205 (rear), and C227. Capacitor C201 is adjusted during alignment. Switch S203 connects either section A or B or both of C224 in parallel with C203. The secondary winding of T201 and R201 provides a dc path for biasing the grid of the first rf amplifier. To prevent reactive effects between the transformer in use and the transformer next lower in frequency, the latter is shorted by S205 (front). In the 0.5- to 1-me band (fig. 57), there is no lower frequency range; therefore, the secondary winding of T203 is shorted instead.

*d.* When antenna relay K101 is operated through the break-in relay circuit, both antenna-input circuits are grounded.

*e.* Resistor R126 and lamp 1103 prevent damage to the receiver from static electrical charges or rf energy from a nearby transmitter. A gradual accumulation of a static charge is prevented by R126. Sudden charges cause 1103 to conduct, discharging them to ground.

*f.* Switches S201 through S205 are sections of a six-position band switch which is operated by the MEGACYCLE CHANGE control. When the band switch is rotated to a new position, the following operations occur simultaneously:

- (1) One of the six antenna transformers is inserted into the input circuit (depending on the selected operating frequency).
- (2) Both, or either, of the two sections of ANT. TRIM capacitor C225 are added to the antenna circuit.
- (3) One of the unused transformer secondary windings is short-circuited.

*g.* The antenna circuit covers a range of 0.5 to 32 me in six bands; 0.5 to 1 me (T201), 1 to 2 mc (T202), 2 to 4 mc (T203),

4 to 8 mc(T204), 8 to 16 mc (T205), and 16 to 32 mc (T206).

### 5. First Rf Amplifier V201

(fig. 57)

The rf input signal from the antenna circuit is amplified by first rf amplifier V201 and applied to second rf amplifier V202. Since the operation of this stage is similar on all bands, only the 0.5- to 1-mc band will be covered.

a. The input signal is applied to the control grid of V201. The plate circuit is completed through contacts 7 and 8 of S206 to plate load Z201. The signal voltage developed across the plate load is coupled through contacts 7 and 8 to S207 and C251 to the control grid of V202. The output voltage is taken from the junction of C233 and C333, which form a voltage divider for rf. This maintains a of Z201 which is higher than it would be if the signal were taken from the top of the tuned circuit.

b. The grid bias for the first and second rf amplifiers is developed across RF GAIN control R123. Agc voltage is supplied to the control grid through R202, the secondary of T201, S205, and R201. Resistor R201 and capacitor C227 develop a bias voltage when strong off-tune signals are present and prevent this bias voltage from affecting the age line.

c. Voltage for the plate and screen circuits is applied through FUNCTION switch S107 (front) in all positions except STAND BY and OFF. An external rf gain control may be connected between terminals 1 and 7 (ground)of TB 102 (TM 11-5820-357-20).

d. The functions of the remaining parts are listed in the chart below.

Part	Function
R202 and C343 .....	Agc decoupling network.
R203 .....	Cathode bias.
R205 .....	Screen-dropping resistor.
R206 .....	Plate-dropping resistor.
C229 .....	Cathode bypass.
C230 .....	Screen bypass.
C231 .....	Rf gain noise filter.
C250 .....	Plate decoupling.
C341 .....	High-frequency bypass.
L246 and C339 .....	Low-pass filter for B+ circuits..
E206 .....	Test point for grid voltage measurement.

### 6. Second Rf Amplifier V202

(fig. 58)

Second rf amplifier V202 amplifies the output signal from the first rf amplifier. The gain of this stage is controlled by RF GAIN control R123 and by the age voltage front the age circuit.

a. The input signal is applied through C251 and parasitic suppressor R221 to the control grid of V202. Agc voltage is applied to the control grid through R208, R207, and R221. The amplified signal appearing at the plate is applied through S208 to tuned circuit Z207. The junction of voltage divider capacitors C256 and C335 is coupled through C274 to the grid of the first mixer and to Z213 which is identical with Z207.

b. To prevent inductive coupling between them, tuned circuits Z207 and Z213 are individually shielded; a separate slug for each circuit is mounted on the 0.5- to 1-mc, tuning rack. Trimmer capacitors C225 and C276 are adjusted during alignment.

c. In addition to tuned circuits Z207 and Z213, which cover the 0.5- to 1-mc range, five pairs of inductors(fig. 74) cover the additional ranges. Varying the degree of insertion of powdered-iron cores tunes the circuits to resonance.

d. The functions of the remaining parts are listed below.

Parts	Function
R207 .....	Grid resistor.
R208 and C252 .....	Ago decoupling circuit.
R209 and C253 .....	Cathode bias resistor and bypass capacitor.
R210 and R211 .....	Screen voltage divider.
C254 .....	Screen bypass capacitor.
E207 .....	Alignment test point.

### 7. First Mixer V203

(fig. 59)

The first mixer stage is used only on the 0.5- to 8-mc ranges. The output from first crystal oscillator V401 (para 8) is heterodyned with the signal from the second rf amplifier in the mixer stage to produce a signal variable between 9 and 18 mc.

a. The input signal is applied to the control grid of V203 through parasitic suppressor R214. The injection signal from the first crystal oscillator is applied through

T401 to the cathode of V203. The plate circuit of V203 is tuned over the 9- to 18-mc range when the positions of the cores in Z219 through Z221 are changed. The 9- to 18-mc signal is fed through C307 and C310 to S210.

*Note:* Tuned circuits Z219 through Z221 are high-Q tuned circuits, capacitively coupled by C307 and C310. The combination results in narrow bandpass, effective image rejection, and high signal-to-noise ratio.

b. Switch S210 (rear) connects the first mixer output to second mixer V204 for the 0.5- to 8-me range (four bands), and connects the output of second rf amplifier V202 to the second mixer for the 8- to 32-mc range (two hands). In the 8- to 32-mc range, switch S210 (front) grounds the output of V203.

c. The functions of the remaining parts are listed below.

Part	Function
E208	Test point for test and alignment.
R213	Grid resistor for V203.
R215 and C304	Plate decoupling network.
R404 and C404	Cathode bias resistor and cathode bypass capacitor.
C303 and C308	Part of plate tuned circuits
C306, C309, C311	Alignment adjustments
L24G anal C339	B+ decoupling network.

## 8. First Crystal Oscillator V401

The first crystal oscillator provides injection voltages to first mixer V203. The tube operates as an electron-coupled oscillator; the screen grid functions as the anode. Oscillations are coupled to the plate circuit through the electron stream of the tube. The stage is operative only for the 0.5- to 8-me input signal range, the area where triple conversion is used in the receiver.

a. The crystal is connected between the control grid and ground. Because capacitor C438 grounds the screen grid for rf, the feedback path between the control grid circuit and the screen grid is complete. The ratio of the values of C401 and C402 determines the amount of feedback that is applied to the control grid; the signal is taken from C401.

b. Minimum bias is developed by cathode bias resistor R402; grid leak bias developed by R401 and the series combination of capacitors C401 and C402. The cathode is kept above ground rf potential by choke L401.

c. The plate load is T401, to which B+ voltage is applied through the decoupling network made up of R403, L406, C403, C436, and C440. Transformer T401 is tuned by C414 and C415 when crystal Y401 is in use. When other crystals are switched into the circuit, S404 selects capacitors other than C415 (*d* below). The secondary of T401, C404, and R404 form the cathode circuit of first mixer V203 (para 7).

d. To cover the eight steps in the incoming signal range of 0.5 to 8 me, five crystals and five sets of tuning capacitors are selected by S402 and S404 respectively. The tuning capacitors, with the primary of T401, form a tuned circuit that is the plate load for V401. The chart below shows the crystal in use for each step, together with the tuning capacitors selected and the contacts used on S402 and S404. The contact numbers are the same as the megacycle indication on the front-panel frequency indicator.

Crystal	Fundamental frequency	Trimmer selection	Contact on S402
Y401	9 mc	C414 and C415	0 and 6.
Y402	8 mc	C414 and C418	1 and 5
Y403	10 mc	C414 and C416	2 and 7
Y404	12.6 mc	C414	3.
Y405	7 mc	C414 and C417	4.

*Note:* Capacitor C414 is made up of five variable capacitors.

## 9. Second Mixer V204

(fig. 2)

The second mixer stage is used on all frequency bands. On the eight lower-frequency bands, signals from first mixer V203 are applied to the second mixer. On the 8- to 32-mc range, signals from the second rf amplifier are applied to the second mixer. The input signals mix with the output of the second crystal oscillator stage to produce a signal of 2.5 to 2 me when the receiver is set to the 0.5- to 1-me band, and 3 to 2 me, on all other bands. These variable frequencies are the difference between the two input signals.

a. Input signals are applied through C312 to the control grid of V204. The injection signal from the second crystal oscillator is applied to the cathode through T402. The output signal at the mixer plate is applied through capacitors C316, C319, and C322 to the grid of third mixer V205.

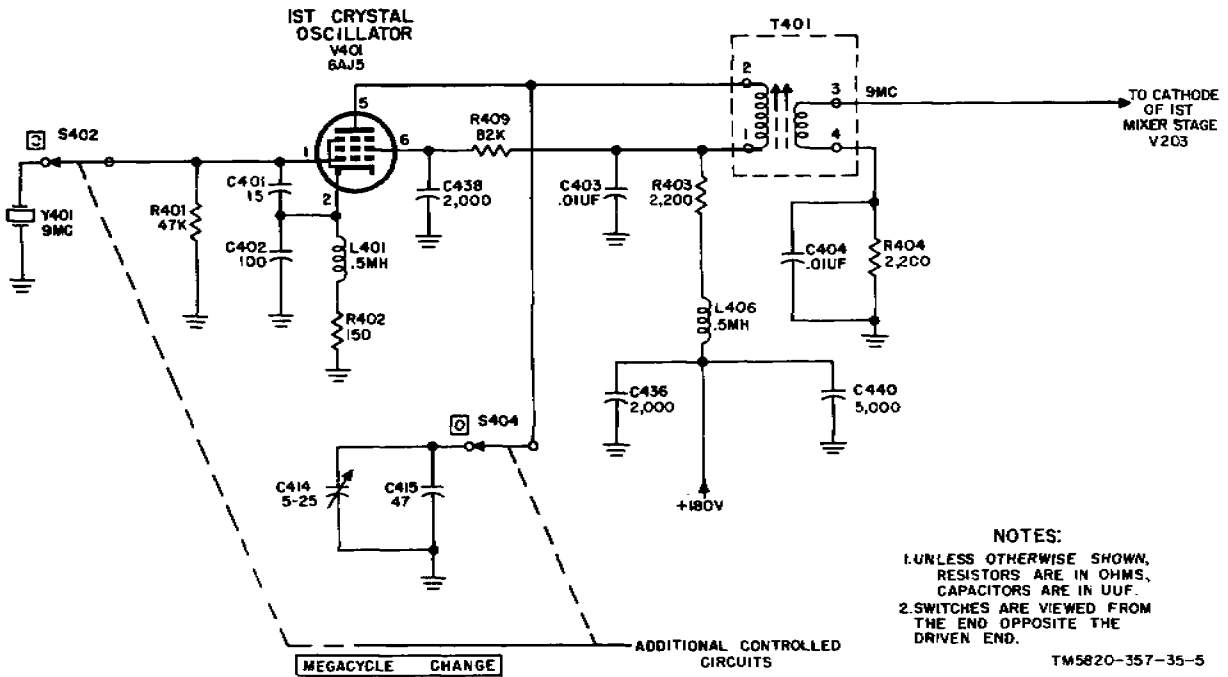

Figure 1. First crystal oscillator, simplified schematic diagram.

b. Positioning the powdered-iron cores in coils Z222, Z223, and Z224 varies the plate circuit over a range of 3 to 2 mc.

c. The functions of the remaining parts are listed below.

Parts	Function
R216	Grid resistor.
L246, R217, C313, and C339	Plate circuit decoupling.
R408 and C408	Cathode bias network.
C315, C318, and C321	Part of plate-tuned circuits.
C314, C317, and C320	Alignment trimmers.

### 10. Second Crystal Oscillator V402

(fig. 3)

a. The second crystal oscillator provides an injection signal to second mixer V204 on all bands. Except for part reference designation, this stage is the same as the first crystal oscillator (para 8); therefore, only the crystals, trimmers, and switch positions used to obtain various frequency ranges will be covered.

b. The chart below shows the crystal reference designation, its fundamental frequency, and the position of the wiper contact on S401. This position corresponds to the reading of the two left-hand digits

on the front panel frequency indicator. For example, when the switch contact is in position 2, the first two left-hand digits indicate 02.

Crystal Symbol	Fundamental freq in mc	Position of S401 wiper contact
Y406	12	0, 1, 9, 21
Y407	15	2, 12
Y408	6, 2	3
Y409	14	4, 11, 25
Y410	8	5, 13
Y411	9	6, 15, 24
Y412	10	7, 17, 27
Y413	11	8, 19, 30
Y414	13	10, 23
Y415	8.5	14
Y416	11.333	31
Y417	10.666	29
Y418	10.333	28
Y419	9.666	26
Y420	12.5	22
Y421	11.5	22
Y422	10.5	18
Y423	9.5	16

c. The chart below lists the trimmer sections of C420 and the fixed capacitors that are

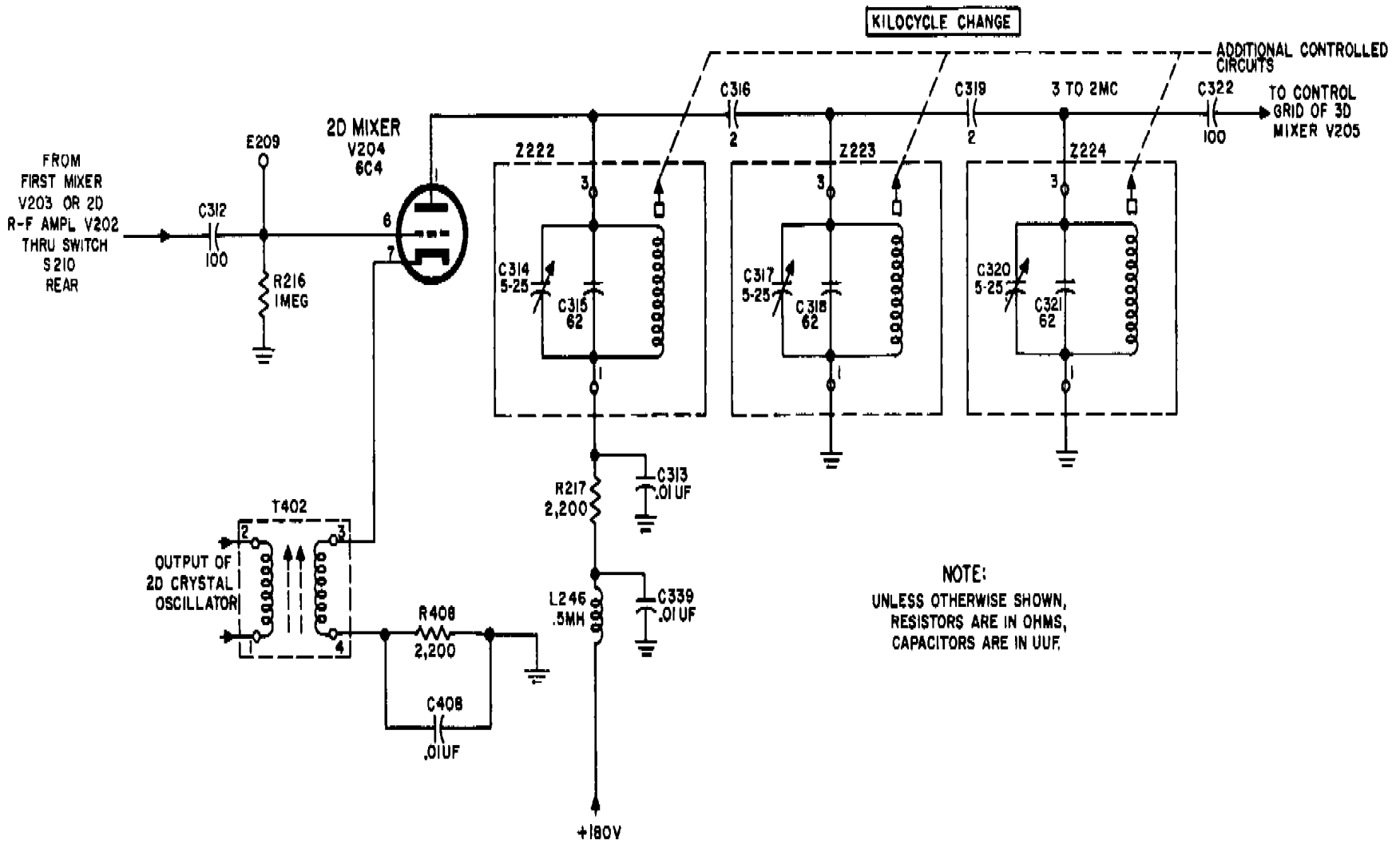

Figure 2. Second mixer stage, simplified schematic diagram.

connected into the plate circuit of V402 when switch S403 is rotated.

Position of S403 wiper contact	Capacitors connected into plate circuit of V403
0. 1, and 9.....	C420A and C419.
2 and 12.....	C420B and C421.
3, 6, and 15.....	C433, C420C, and C422.
4 and 11.....	C420D and C423.
5 and 13.....	C420E and C424.
7 and 17.....	C420F and C425.
8.....	C420G and C426.
10.....	C402H and C427.
14.....	C420I and C428.
16.....	C420J and C429.
18.....	C420K and C430..
19.....	C420L and C431.
20.....	C420M and C432
21.....	C420N.
22.....	C420P.
23.....	C420P.
24.....	C420Q.
25.....	C420R.
26.....	C420S.
27.....	C420T.
28.....	C420U.
29.....	C420V.
30.....	C420W.
31.....	C420X.

d. The 24 trimmers contained within C420 are adjustable and are used during alignment. Paragraph 51 lists the crystals, their fundamental frequencies, and the bands on which they operate. Frequency tripling can be obtained by use of series capacitor C433 to decrease the total capacitance introduced into the tuned primary of T402.

### 11. Third Mixer V205

(fig. 4)

The third mixer receives signals from second mixer V204 and variable frequency oscillator V701 to produce a 455-kc difference or intermediate frequency signal.

a. The 3- to 2-me output signal of second mixer V204 is coupled to the third mixer grid through C322. The 3.455- to 2.455-mc vfo signal is applied to the cathode through T701. The plate circuit of the third mixer consists of T207 (composed of capacitor C324, primary winding L240, an d secondary winding L241). Transformer T207 has a broad bandpass at 455-kc and an adjustable core for alignment purposes. The 455-kc signal from the third mixer is applied to first if. amplifier V501, through the crystal filter circuit (para 13).

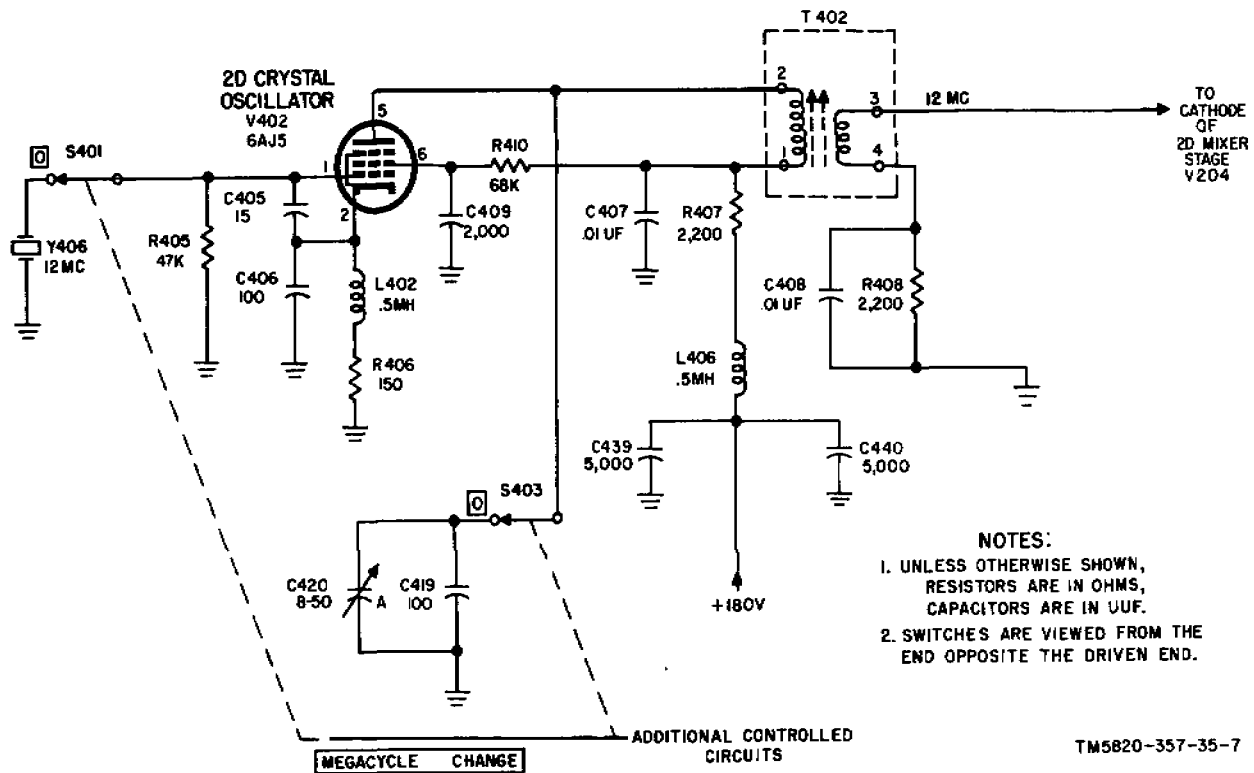

Figure 3. Second crystal oscillator, simplified schematic diagram.

b. The parts comprising Z702 are covered in paragraph 12. The functions of the remaining parts are listed below.

Part	Function
R218	Grid resistor.
R219 and C323	Cathode bias network.
R220 and C325	Plate decoupling network.
L246 and C339	B+ decoupling network.

## 12. Variable Frequency Oscillator V701

(fig. 5)

The variable frequency oscillator is a Hartley-type oscillator that produces the necessary injection signal for the third mixer stage. The frequency range is from 2.455 to 3.455 kc. Tuning unit Z701 is completely enclosed in a hermetically sealed can that contains a heating unit to maintain the temperature at 75° C. The temperature is controlled by thermostat switch S701 (fig. 66). Certain changes were made to vfo's stamped MOD 1. Aside from some value changes, the differences are in the output circuits. These differences are apparent in figure 5.

a. The oscillator tank circuit is made up of C701 and the series combination of L701 and L702. Capacitors C702 and C703 are temperature-compensating capacitors to maintain frequency stability with changes in temperature.

- (1) Feedback is provided by induction from the portion of L702 between the tap and ground. Plate current flows through this portion.
- (2) The screen grid functions as the anode of the oscillator; it is held at rf ground potential by C705. Grid leak bias is developed by coupling capacitor C704 and grid resistor R701. Screen grid voltage is dropped by R702.
- (3) The output of the stage appears across the secondary of T701, which is in series with the cathode of third mixer V205.
- (4) In the unmodified model (A, fig. 5), the primary of T701 is untuned. The components in the secondary circuit provide for proper bandpass characteristics. In MOD 1 versions, (B, fig. 5), the primary is tuned and the secondary circuit is simplified.

b. As the receiver is tuned from the lowest to the highest frequency in any particular band, a powdered-iron slug within L702 moves to change the frequency of the vfo over its range. The slug covers its range in exactly ten turns of a lead screw that is turned by the KILOCYCLES CHANGE control. Coil L701 is an end-point adjustment to obtain a 1-mc range for ten turns of the lead screw and to permit the vfo to track with the other tuned circuits in the receiver.

c. In A, figure 5, R703, C706, and C707 decouple the oscillator from the power supply. This function is performed by L703 and C706 in B, figure

## 13. Crystal Filter

(fig. 6)

The crystal filter is part of the bandwidth control system that provides varying degrees of selectivity. A narrow bandpass of 0.1 and a narrow 1-kc bandpass are provided by Z501. A 455-kc crystal is used in this circuit.

a. The circuit consists of one-half of the secondary of L241 (between terminals 3 and 4), crystal Y501, resistors R502, and R561, and capacitor C502. Inductance L and capacitance C form a tuned circuit that is resonant at the crystal frequency. A variable capacitor is connected between one end of the crystal holder for Y501 and the other half of secondary L241 (terminals 2 and 3). This capacitor supplies an out-of-phase voltage to the control grid of V501 to neutralize the capacitance of the crystal holder.

b. When BANDWIDTH switch S501 is in the .1 and 1 KC positions, the 455-kc signal is applied to Z501; on the remaining four positions of the control marked 2, 4, 8, and 16 KC, the signal is applied directly to the control grid of V501 through C503. With the switch in the last four positions, C503 provides an rf short-circuit for Y501. In the first two positions, C503 serves as a low-impedance connection at the intermediate frequency to R561.

c. With S501 in the .1 KC position, the crystal is loaded by R502 and C502; R561 is hunted across R502 through C503. With S501 in the 1 KC position, the circuit is loaded by R502 and C502; R561 is removed from the circuit.

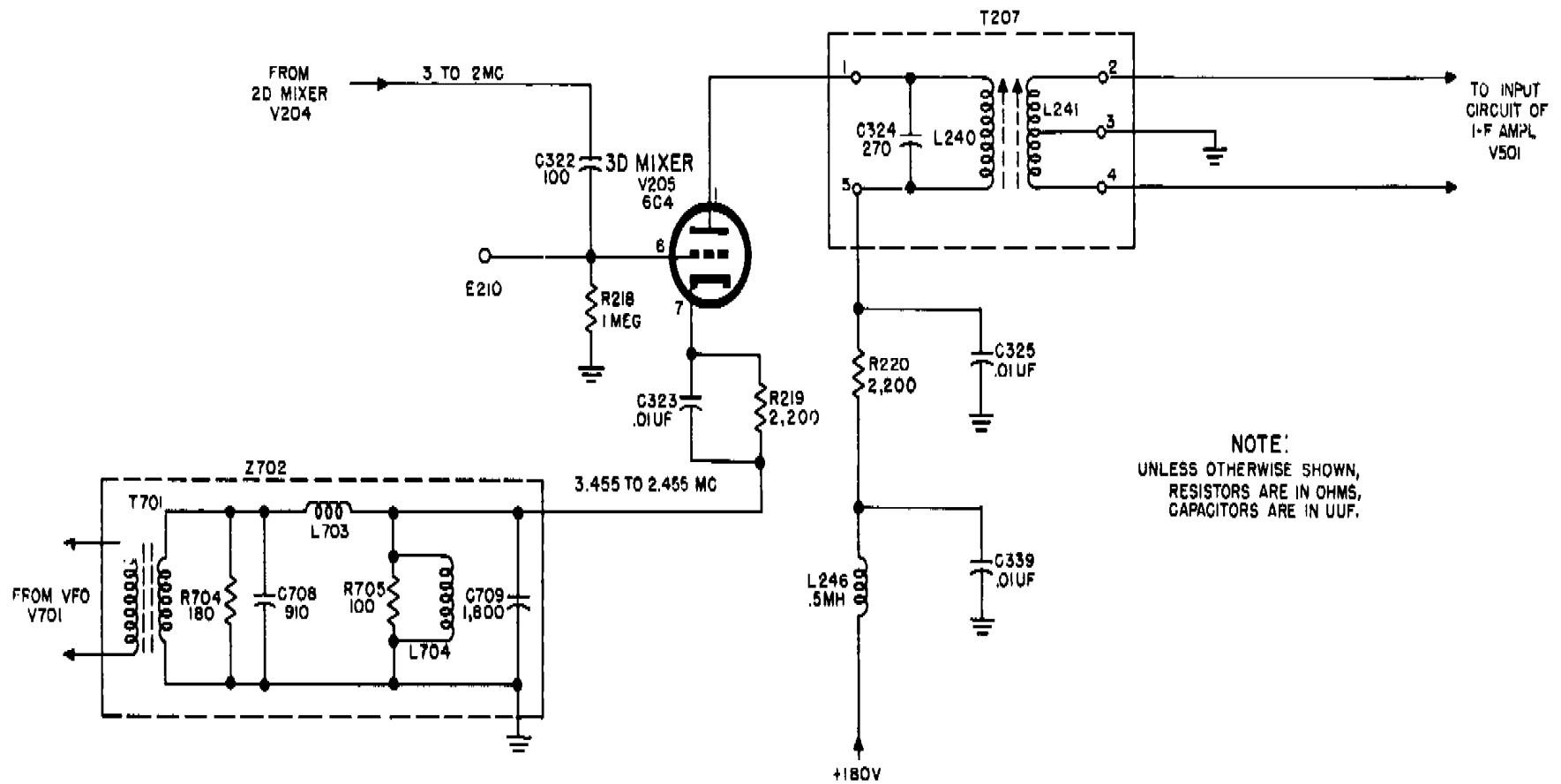

TM5820-357-35-8

Figure 4. Third mixer, simplified schematic diagram.

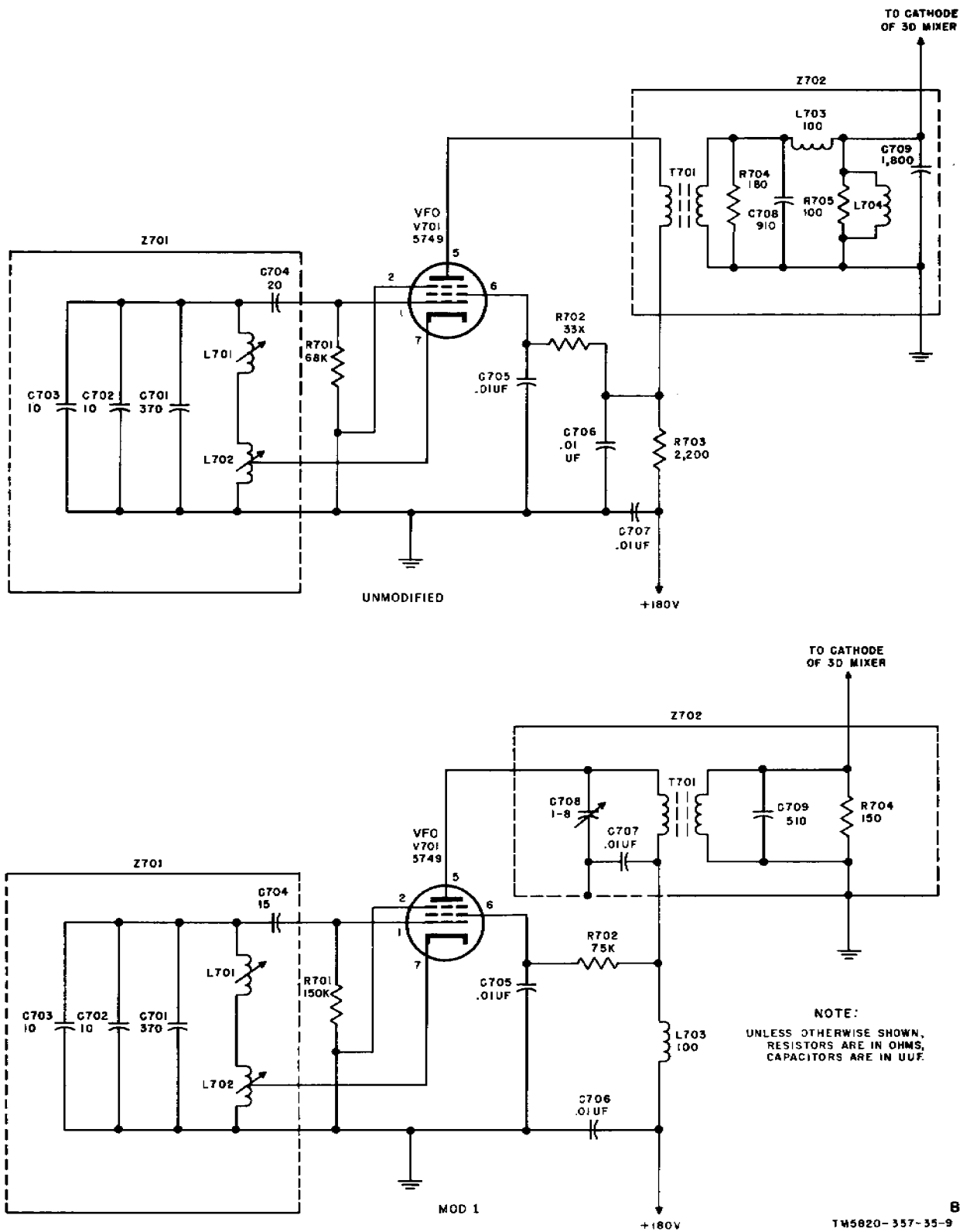

Figure 5. Variable frequency oscillator, simplifies schematic diagram.

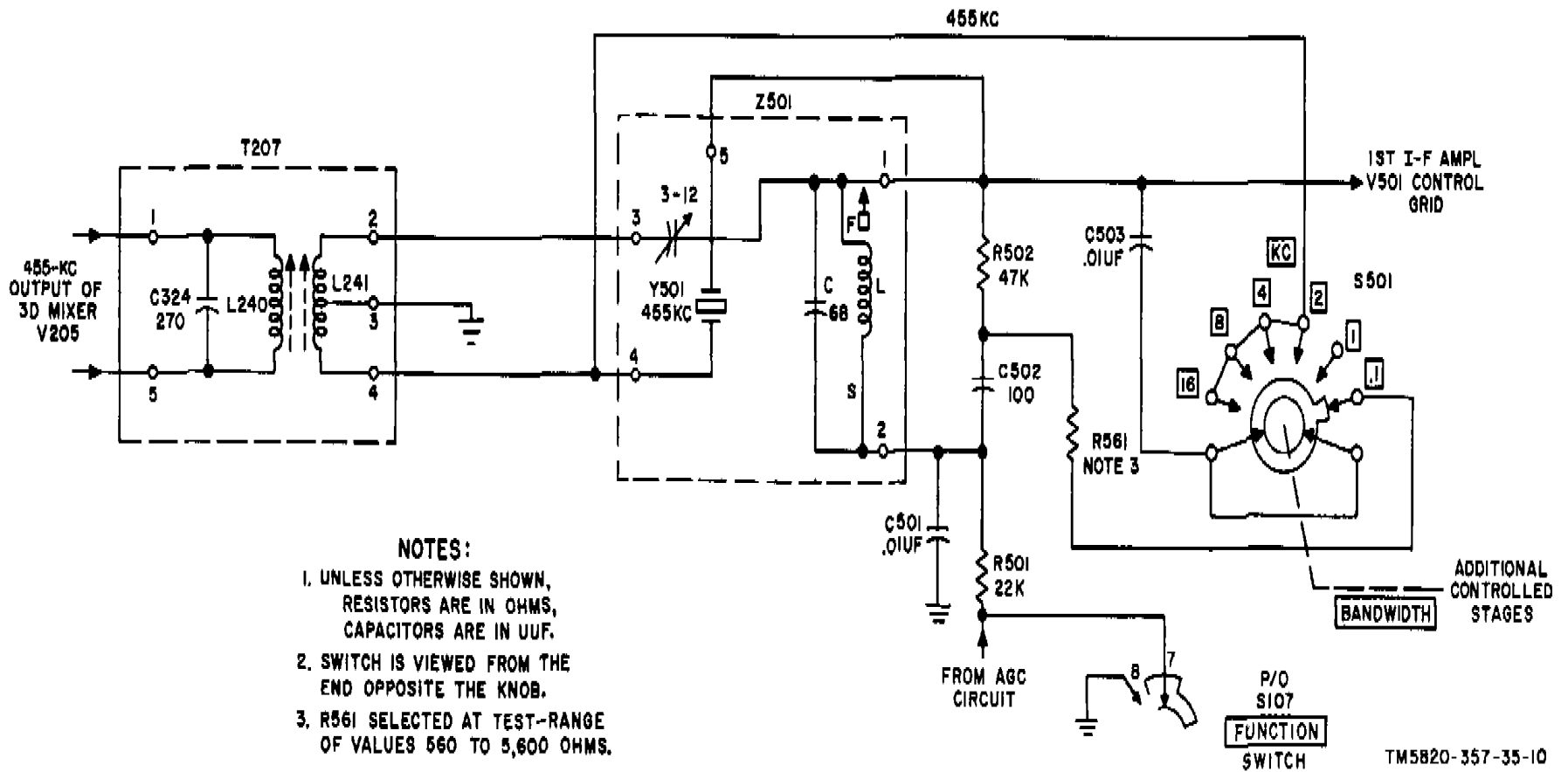

Figure 6. Crystal filter, simplifies schematic diagram.

## 14. Intermediate Amplifiers V50, through V506

(fig. 74)

*a. General.* The if. subchassis consists of six stages. The output of the fifth if. stage is applied to age amplifier V509, age rectifier V510, and through cathode follower V511, to output jack J512. The sixth if. stage forms part of the CARRIER LEVEL meter circuit; its output is applied to detector V507A. The gain of the if amplifier section is controlled manually by the RF GAIN control when the FUNCTION switch is set to MGC, CAL, and SQUELCH. The gain is also controlled automatically by the age circuits when the FUNCTION switch is in the AGC, CAL, or SQUELCH position. The BANDWIDTH switch controls the degrees of selectivity of the if. transformers.

*b. If. Selectivity.* The bandpass of the if. amplifier system can be varied in six steps by the BANDWIDTH control over a range extending from .1 KC to 16 KC. This range is obtained by crystal filter Z501 (para 13) and by control of the mutual coupling between the windings of the inter stage transformers (T501 through T505). The degree of coupling in the transformers is controlled by the use of additional coils wound on the same form as the primary or secondary winding. Three of these coils are used in T501(fig.74) while four are used in the remaining if. transformers. One coil is connected to each transformer at a time to produce a given degree of coupling. A series coupling circuit, that includes contacts of BANDWIDTH switch, a selected coil, and a capacitor and resistor in parallel, is connected across each secondary winding to obtain the desired bandwidth. Resistors are included in series with the coupling coils, when needed, to increase the bandwidth. The transformer windings in use for the various positions of the BANDWIDTH switch are described in (1) through(4)below.

- (1) When the BANDWIDTH switch is in the position marked .1, 1, or 2 KC, transformer coupling circuits remain unchanged; narrow bandwidths for the .1 KC and 1 KC positions depend on circuit changes in crystal filter Z501 (para 13). In these three positions of the BANDWIDTH switch, the

coupling coil in T501 is phase-aiding; it is the one mounted at the greatest distance from the primary winding. The coupling coils in T502 through T505 are also phase-aiding; they are third in distance from the primary winding.

- (2) When the switch is in the 4 KC position, the coupling circuit of T501 remains the same. Coupling coils that are phase-aiding and located at the greatest distance from the primary windings of T502 Trough T505 are used (fig. 74).
- (3) When the switch is in the 8 KC position, the middle coupling coil of T501 and resistor R507 are connected into the coupling circuit. The coupling coils in the second positions from the primary windings of T502 through T505 (fig.74) R514, R524, R529, and R534 are included in the remaining coupling circuits. In this switch position, the windings of T501 are not coupled as closely as the windings of T502 through T5G5.
- (4) When me switch is in the 16 KC position, the coupling coils nearest the primary windings of all transformers are included in the coupling circuits. Resistor R508 is in series with the coupling coil of transformer T501; R515, R525, R530, and R535 are m series with the coupling coils of T502 through T505 respectively.

## 15. First If. Amplifier V501

(fig. 7)

Depending on the position of the BANDWIDTH switch, the 455-kc it signal from third mixer V205is fed to the first if. amplifier through crystal filter Z501, or directly from the third mixer stage. The amplified if signals are coupled to second if amplifier V502 for further amplification.

*a.* The 455-kc if. input signal is fed to the control grid of V501. The grid circuit is returned to the age circuit (para 22) through Z501 and R501 (fig. 6).

*b.* In addition to the age voltage (para 22) applied to V501, the gain of the first if amplifier can be manually controlled by variation of the value of cathode bias with RF GAIN

control R123. External control of the rf gain can be achieved by removal of the Jumper between RF GAIN terminals 1 and 2 of TB102 and connection of 5,000-ohm potentiometer between terminal 1 and ground.

c. The plate circuit is completed to B+ through the primary of T501. The screen grid is connected to the junction of R504 and R505 which, with GAIN ADJ control R562, form a voltage divider across the 180-volt supply.

d. Three degrees of selectivity are obtainable by connection of one of three additional coils in T601, through the contacts of S502 (para 14b).

e. The functions of the remaining parts are listed below.

Part	Function
R503 and C505 .....	Cathode bias network.
R506 and C507 .....	Plate decoupling network.
C506 .....	Screen grid bypass capacitor.
L501 and C504 .....	Isolation from cathode circuits of other controlled stages.
L503, L530, and C531 .....	Plate decoupling network for V501 and V502.

### 16. Second If. Amplifier V502 (fig. 7)

The output of the first if. amplifier is coupled to the second if amplifier through T501. The signal input is amplified and applied to the third if amplifier.

a. The control grid is returned to ground through a portion of the secondary winding of T501. The plate circuit is completed to B+ through the primary winding of T502. Four degrees of selectivity are available by connection of one of the four additional coils in T502, through the contacts of S503 (para 14b). GAIN ADJ control R562 provides for presetting the if. gain by adjusting the cathode bias on V502.

b. The functions of the remaining parts are listed below.

Part	Function
R510, R562, and C509 R512	Cathode bias network. Screen grid voltage dropping resistor

Part	Function
C510	Screen grid bypass capacitor.
C511 and R513	Plate decoupling network.

### 17. Third and Fourth If. Amplifiers V503 and V504 (fig. 60)

The third and fourth if amplifier stages amplify the 455-kc signal from the second if. stage and apply this signal to the input circuit of the fifth if. amplifier.

a. The if. signal from the second if amplifier is coupled, through C512, to the control grid of V503. The signal voltage is developed across grid resistor R516. The signal at the plate of V503 is coupled by T503 to the control grid of V504. The fourth if stage is similar to the third if stage. Corresponding components serve similar functions.

b. Four degrees of selectivity are available by connection of one of four windings in transformers T503 and T504, through BANDWIDTH switches S505 and S506 (para 14b).

c. When S504 is in the .1, 1, or 2 KC position, the common cathode bias circuit for V503 and V504 is completed through R521. As the bandwidth is increased (through the 4, 8, or 16 KC positions of S504), successively lower value resistors, R520, R519, or R518 are substituted. The lower cathode bias thus produces results in increased gain of the two stages, offsetting the reduction in gain from increased bandwidth.

d. The functions of the remaining parts are listed below.

### 18. Fifth If. Amplifier V505 (fig. 61)

The fifth if amplifier amplifies the 455-kc if signal and applies it to the control grids of sixth if amplifier V506, age amplifier V509, and if cathode follower V511.

a. The RF GAIN control operation is the same as for the first if. stage. The input signal is coupled to the control grid of V505 through T604.

b. The functions of the remaining parts are listed below.

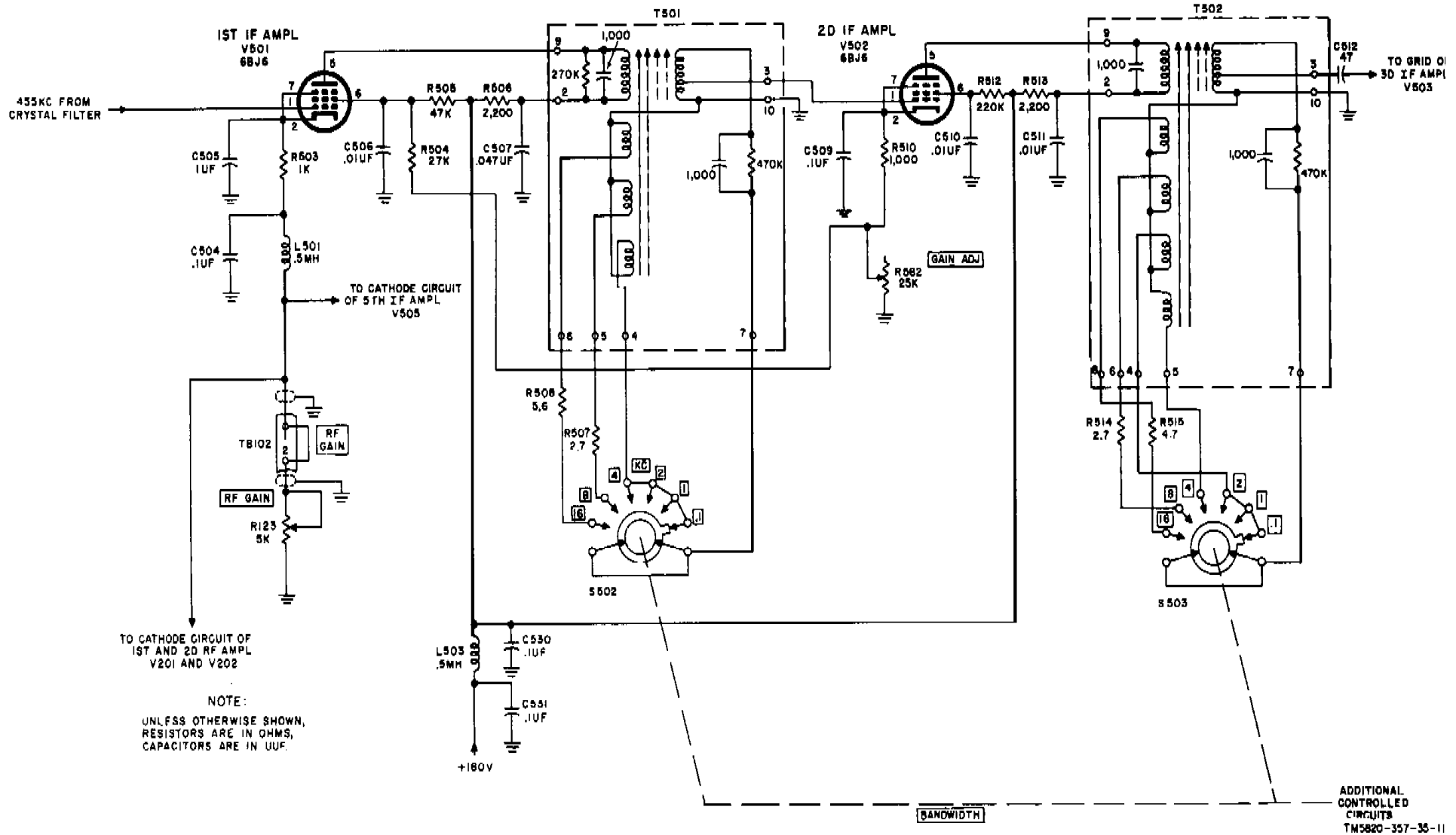

Figure 7. First and second if. amplifiers, simplified schematic diagram.

Part	Function
R509 and C508	Agc isolation network.
R511 and R532	Voltage divider network.
R531 and C520	Cathode bias network.
R533 and C522	Plate decoupling network.
C521	Screen grid bypass

### 19. Sixth If. Amplifier V506

(fig. 61)

The sixth if amplifier amplifies the 455-kc signal from the fifth if. amplifier and applies it to detector V507A. The bandwidth of the sixth if. amplifier will permit any bandwidth selected by the BANDWIDTH switch to pass without attenuation.

a. Capacitor C525 neutralizes interelectrode capacitance between the plate and control grid. This prevents the output signal from beat-frequency oscillator V508 (which is applied to the secondary of T506) from appearing at the input to cathode follower V511.

b. The cathode circuit of V506 forms part of the circuit that operates the CARRIER LEVEL meter (para 22e).

c. The functions of the remaining parts are listed below.

Part	Function
R536 and C523	Cathode bias network.
R538 and C524	Plate and screen decoupling network.
C539	Coupling to V509

### 20. Detector and limiter Circuits V507 and V510

(fig. 8)

The detector rectifies the 455-kc if. signal and the limiter reduces interference by removing noise peaks that exceed the level of the received signal. The output of the limiters is applied to af amplifier V601.

a. *Detector.*

- (1) The plate and control grid of V507A are connected to the secondary of T506. The resulting diode circuit includes the secondary of T506, L502, and diode load resistors R539 and R540.

- (2) The if. signal from the sixth if. amplifier is applied to the detector anode
- (3) through T506. Tube V507 rectifies the signal and an audio voltage is developed across R124, R539, and R540. Choke L502 and capacitor C526 filter the if. signals from the diode load. The audio voltage developed across R540 is applied, through a jumper connection on TB101 to the control grid of squelch tube V601B (para 27). LIMITER control R124, shunted across the load, adjusts the negative voltage to determine the threshold level of the limiters.

- (4) When the bfo is used, the output of V508 is coupled to the detector plate through C536. The output of V508 mixes with the if. input signal to produce a beat note (para 21).

b. *Limiter.* When LIMITER switch S105 is ON, the peak amplitude of the detector output is limited to eliminate noise peaks above the level determined by the setting of R124.

- (1) The limiter circuit consists of two triode tube sections connected as diode series limiters, to provide limiting of both positive- and negative-noise peaks. When LIMITER control R124 is turned to OFF, switch S105 (ganged to the limiter potentiometer) grounds the parallel-connected cathodes through R544. This action also removes the ground connection at the junction of R541 and R542 and applies +180 volts dc to the plate through L503 and R543, which causes the diodes to conduct. When an af signal is applied to the anode of V507B, the af voltage modulates the dc that flows through the diode. This signal appears across R544. Because R544 is common to both diode limiters, this signal is superimposed on the dc that flows through V51 OB and appears across R542. The audio output signal is then coupled through C529 to the control grid of the first af amplifier.
- (2) When LIMITER control R124 is turned clockwise, switch S105 grounds the junction of resistor R541 and R542 and removes ground from the

cathodes of the diodes. Both cathodes assume a negative potential, adjustable by R124. The diode snow function as negative and positive-peak limiters. When current flows through the diodes, the af signal is transferred through the diodes as before; however, any negative-going impulse that exceeds the threshold voltage across R124 will cut off the diode. A positive impulse applied to the plate of V607B will cause the tube to conduct. This action increases the voltage drop across R644. The voltage across R544 opposes threshold voltage, and thereby cuts off V510 and limits any positive impulse. As R124 is turned toward position 10, a less negative voltage is applied to the diodes, and greater limiting results. The threshold voltage varies with the amplitude of the diode load signal; therefore, limiting action is automatic.

- (3) The functions of the remaining parts are listed below.

Part	Function
R125 and C102	Decoupling circuit to decouple the limiter from the detector.
C550	Cathode voltage stabilizing capacitor.
L503, C530, and C531	Af filter for the +180-volt line.
R543 and C528	Plate decoupling network.
C551	If. bypass.
R125	Prevents excess diode loading when S105 is in OFF position.

## 21. Beat-Frequency Oscillator V508 (fig. 9)

The beat-frequency oscillator permits copying cw radiotelegraph signals and aids in the tuning of weak modulated continuous wave (mew) signals. With the BFO switch set to ON, the bfo generates a signal which mixes with the 455-kc if. signal in the detector circuit to produce an audible note in the output. The circuit is similar to the vfo (para 12). Because of its stability, the bfo permits the reception of ssb signals. Its output put replaces the carrier that was attenuated or suppressed at the transmitter. This output and the received sideband are heterodyned in

detector V507A to reproduce the transmitted intelligence.

*a.* The oscillator section of V508 operates as a triode with the screen grid functioning as the anode. Tuned circuit Z502 consists of a tank coil (two inductors in series) and a tank capacitor (three capacitors connected in parallel). Feedback voltage is induced by cathode current flow through the portion of the coil connected between the tap and ground. The oscillating voltage that appears across the rest of the coil is applied to the control grid through C532. The amplified signal at the plate is applied through C536 to the plate of detector V507A. When the BFO control is set to OFF, B+ voltage is removed at S103 from the bfo plate and screen circuits.

*b.* Capacitors C532 and C533 form a voltage-divider network which improves frequency stability by minimizing the effect of the tube input capacitance on the tank coil. The capacitors across the tank coil are temperature-compensating to insure frequency stability.

*c.* The BFO PITCH control varies the output over a range of 452 to 458 kc. When the BFO PITCH control is set to 0, the output frequency is exactly 455 kc (the if.) end no beat frequency is produced in the detector. The calibration points on the front-panel BFO PITCH control indicate the number of kc deviations ( $\pm 3$  kc) from 455 kc.

*d.* The functions of the remaining parts are listed below.

Part	Function
R545	Grid bias resistor.
R547	Plate load resistor.
R548 and C535	Plate decoupling network.
R546	Screen grid voltage-dropping resistor.
C534	Screen grid bypass.

## 22. Agc and CARRIER LEVEL Meter Circuits V509, V510, and V511 (fig. 10 and 62)

The agc circuit operates when FUNCTION switch S107 is turned to AGC, CAL, or SQUELCH. When the switch is in the MGC

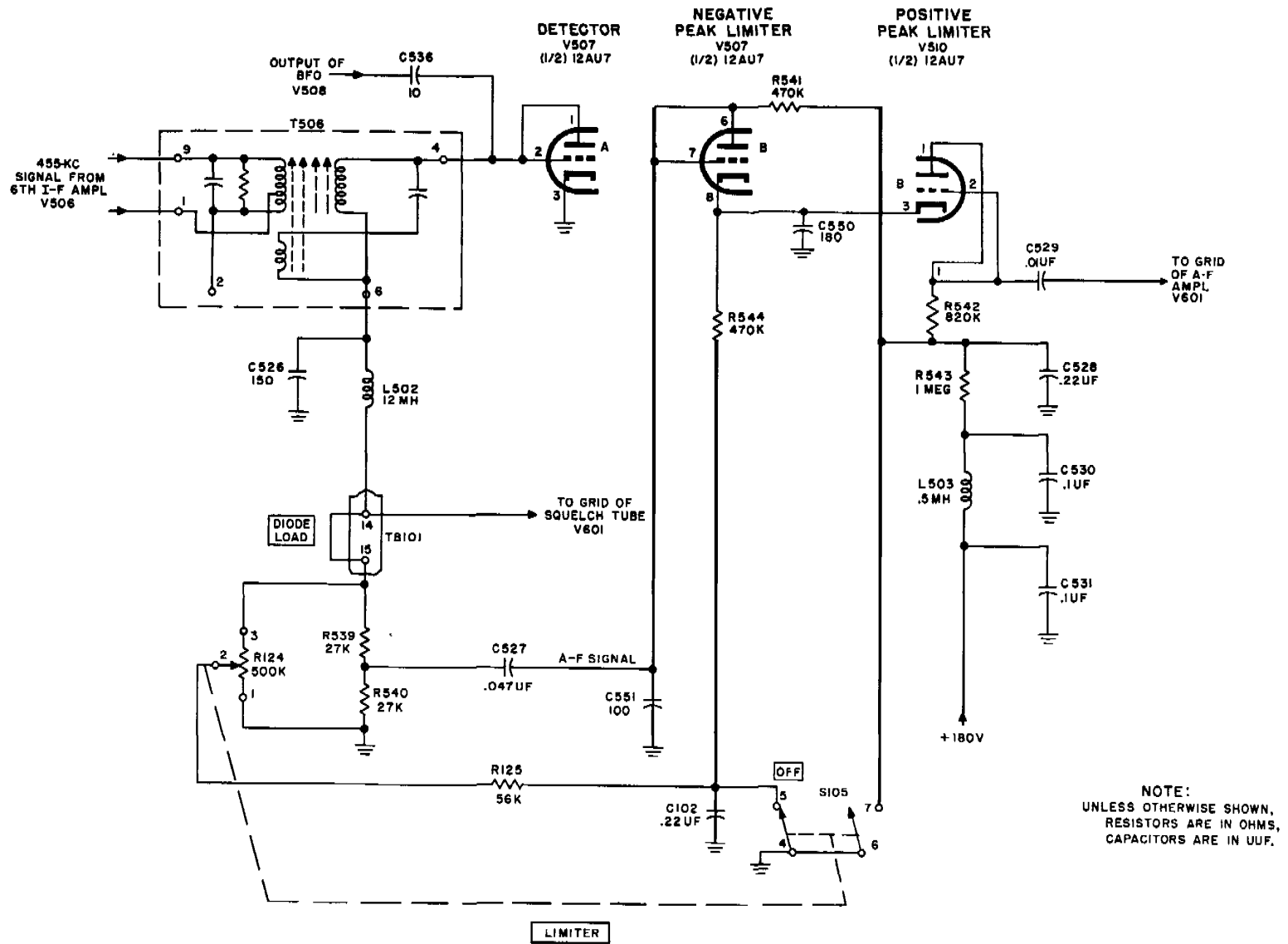

TM5820-357-35-14

Figure 8. Detector and limited circuits, simplified schematic diagrams.

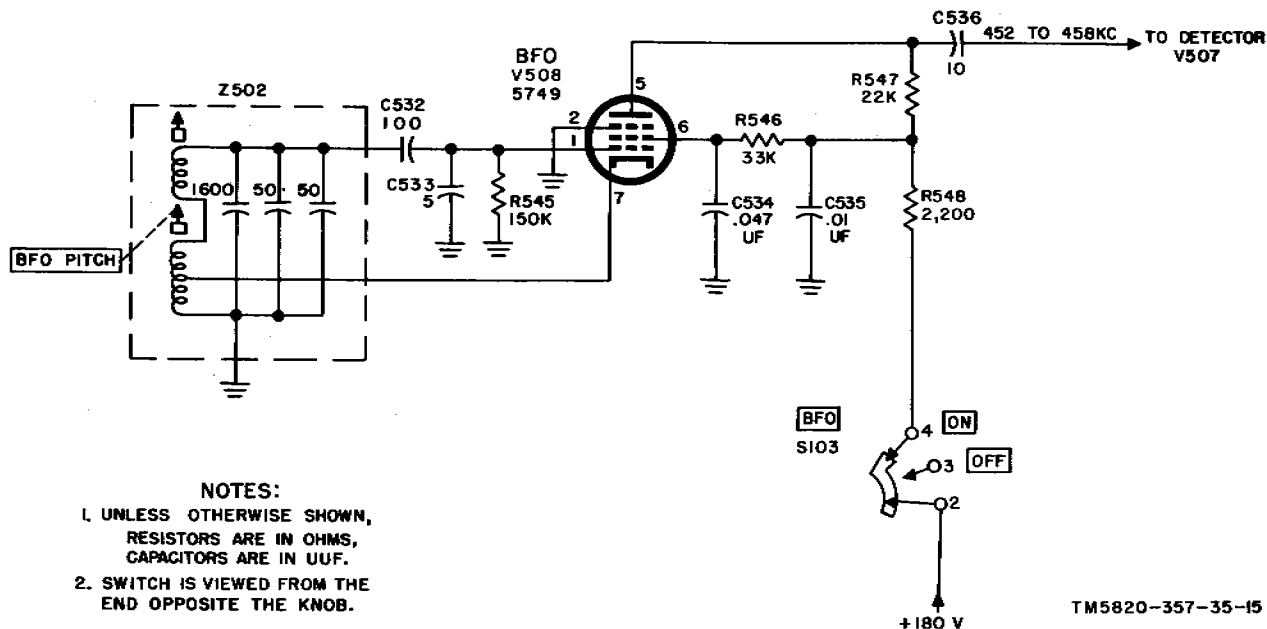

Figure 9. Beat-frequency oscillator, simplified schematic diagram.

position, the agc line is grounded, thus removing the control voltage. A delayed-action system prevents application of age bias voltage to the controlled tubes during the reception of weak signals. The AGC control can be set to FAST, MED. (medium), or slow, depending on the receiving conditions and the type of signal being received. The negative age voltage controls V201, V202, V501, and V505.

a. *Age Amplifier V509.* This stage is similar in operation to if amplifiers V501 through V506.

- (1) The 455-kc signal from the secondary of T505 is coupled to the control grid of V509 through C539. The signal is developed across grid resistor R551.
- (2) The plate receives B+ voltage through Z503. The output signal is developed across the tuned circuit of Z503 and is coupled through C543 to the plate and control grid of age rectifier V510A.

b. *Delayed Age System.* Delay of the age action prevents application of negative bias to the controlled tubes until the if. signal has sufficient strength to produce adequate input to detector V507.

- (1) The age function is made dependent on the strength of the signal. When a weak signal

is being received, a positive potential is applied to the age line. This voltage is too low to overcome the negative bias voltage produced by the cathode resistors of the controlled tubes. When a strong signal is applied to the age rectifier, a negative dc voltage is developed across R555. This negative voltage is applied through R556 and R557, the time constant circuit, and AGC NOR terminals 3 and 4 of TB102 to the controlled stages, which decreases the gain. The age line is grounded when FUNCTION switch S107 is turned to MGC position, and the gain is controlled only by RF GAIN control R123 (para 5).

- (2) When the receiver is used in a diversity receiving system (TM 11-5820-357-10), crystal CR101 prevents agc circuit loading of the controlling receiver by the age circuits of the other receivers.

c. *Time-Constant System.* The time constant of the age line is adjustable in three steps by AGC switch S104. In the FAST position,

the time constant is 0.01 second; in the MED. position, 0.5 second; and in the SLOW position, 4 seconds.

- (1) FAST. When the switch is in the FAST position, the negative age voltage from the if signal filter (R656 and C544) is applied to the second filter (R557 and C545). The time-constant is determined by the capacitance and resistance of the age line.
- (2) MED. When the switch is in the MED. position, C546 and C547 are connected across C545 by S104 to increase the time constant.
- (3) SLOW. When the switch is in the SLOW position, C546 and C547 determine the time constant and the total apparent capacitance is about 10 times as large as in the MED. position. Tube V511A has the control grid connected to the age line. The capacitance between the control grid and plate is multiplied by the gain of the tube and applies a larger apparent input capacitance between control grid and cathode that further increases the time constant of the circuit.

d. *Function.* The functions of the remaining parts are listed below.

Parts	Function
R202, R208, R501, R509, C226, C252, C343, C501, C508 R554 and C542	Decoupling networks to isolate if. and rf circuits from each other and from the age line. Plate decoupling network for V509.
R552 and C540 R553	Cathode bias network. Screen grid voltage dropping resistor.
R555, R556, R558 C541 C544 and C545	Voltage divider network. Screen bypass for V509. If. filters.

e. *CARRIER LEVEL Meter Circuit (fig. 10 and 62).* CARRIER LEVEL meter M102 indicates the relative strength of a received rf signal. Sixth if. amplifier V504, age time constant tube V511A, and their circuit components form a bridge circuit. Meter M102 indicates the bridge unbalance.

- (1) The resistors drawn in parallel with the tubes in figure 10 show that V506 appears as a constant resistance in the bridge circuit

and that V511A is the variable element. The changing resistance in V511 A is caused by variations in age voltage from age rectifier V510A.

- (2) With no received signal, and with the RF GAIN control turned fully clockwise (to produce zero age voltage), CARR-METER ADJ control R537 is adjusted until M102 indicates zero. At this point the voltages between each side of the meter and ground are equal; the bridge is balanced and no current flows through the meter.
- (3) When a signal is received, age voltage is applied to V511A; its plate current decreases and so does the voltage drop across R559. The bridge is now unbalanced and current flows through M102. The stronger the received signal, the larger is the age voltage applied to V511A and the greater is the pointer deflection on M102.
- (4) When the FUNCTION switch is set to MGC, the control grid of V511B is grounded; normally the meter will indicate zero. If a signal applied to V506 is strong enough to draw grid current and unbalance the bridge, the meter will show an indication. This is an overload; the RF GAIN control should be reduced until the meter indicates zero.
- (5) The functions of the remaining parts are listed below.

Part	Function
R536 C523 R537 R538	Minimum bias resistor for V506. Cathode bypass capacitor for V506. CARR-METER ADJ control. Decoupling resistor for the sixth if. amp.
R559 R560 C530 C531, and L503	Cathode bias resistor for V511. Plate load resistor for V511. Plate decoupling network.

### 23. If. Cathode Follower V511 (fig. 11)

The cathode follower stage couples the 455-kc if signals from the secondary winding of transformer T505 to a low-impedance cable. This is used for applying frequency shift, teletypewriter signals to conversion equipment.

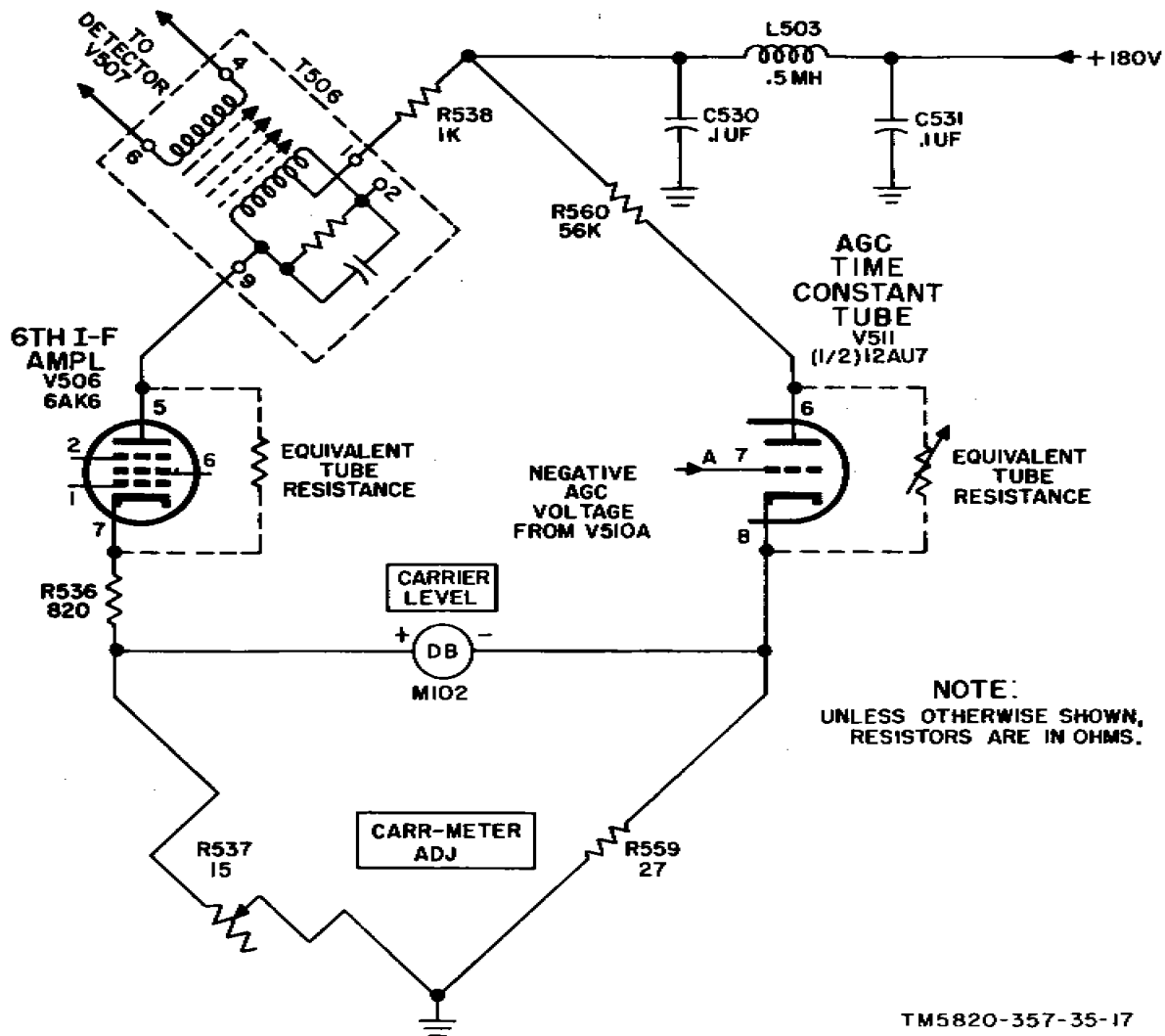

Figure 10. CARRIER LEVEL meter circuit, simplified schematic diagram.

a. The signals from fifth if. amplifier V505 are applied to the control grid of V511 through the secondary of T505. The plate dc path is, through chock L503 to B+. Because capacitor C537 offers a low-impedance path to the if. signal, the output signal is developed across cathode load R550 and applied to J106 IF OUTPUT 50 OHM through C538.

b. The functions of the remaining parts are listed below.

Parts	Function
R549 and C537	Cathode bias network.
L503, C530, and C531	Plate decoupling network.

## 24. At Amplifier V601A and Filter Circuits

(fig. 63)

Af amplifier V601 A amplifies the audio signal from the limiters for application to the local and line

audio channels. For best reception of certain types of transmissions, the audio signals are routed through a selected filter to eliminate unwanted frequencies.

a. The input signal is developed across grid resistor R601 and is applied to the control grid of V601A. The amplified signal, appearing across the secondary of T601, is routed through AUDIO RESPONSE switch S102 to resistors R105, R103, and R104. The input to local af amplifier V602A is taken from LOCAL GAIN control R104; the input to line af amplifier V602B is taken from LINE GAIN control R103.

b. When S102 is in the SHARP position, for reception of radiotelegraph signals accompanied by a high noise level, the circuit through FL601 is completed through contacts 2 and 3, and 8 and 9.

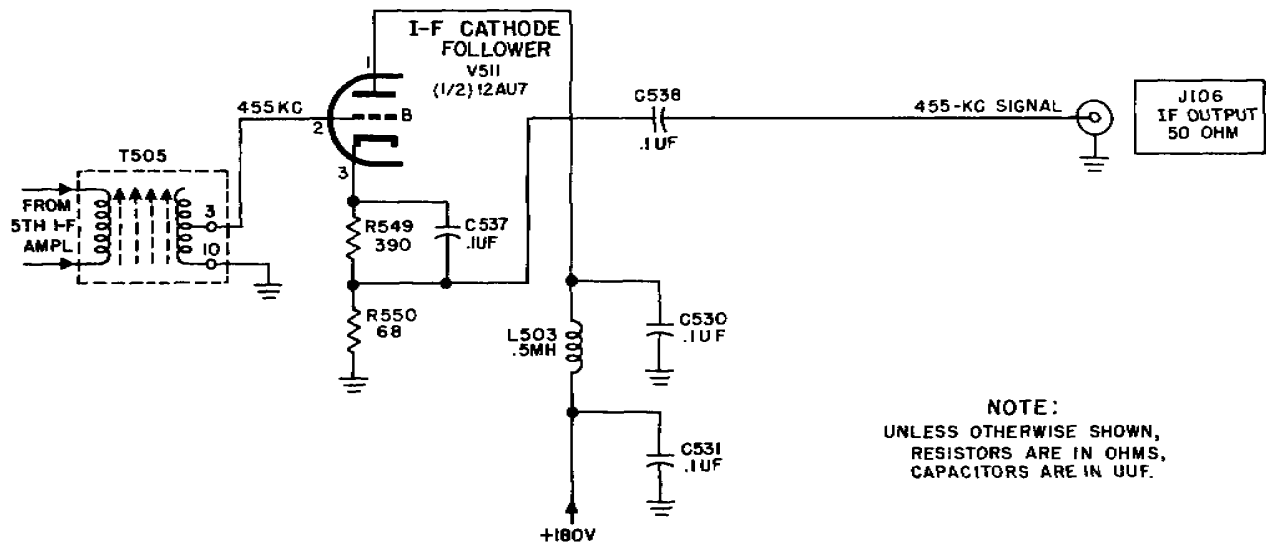

TM5820-357-35-18

Figure 11. If. cathode follower, simplified schematic diagram.

c. When S102 is in the MED. (medium) position, for reception of voice signals with noise above 3,500 cycles per second (cps) cut off, the circuit through FL602 is completed through contacts 2 and 4, and 8 and 10. Resistors R106, R107, and R108 form a pad to attenuate the signals to a level approximately equal to that produced when S102 is in the SHARP position.

d. When S102 is in the WIDE position, to use the full frequency response of the receiver, the circuit is completed through contacts 2 and 5, and 8 and 11. Resistors R109, R110, and R111 form a pad to attenuate signals to a level approximately equal to that produced when S102 is in the SHARP position.

e. The functions of the remaining circuit parts are listed below.

Parts	Function
R602	Cathode bias resistor.
R603 and C601	Plate decoupling circuit.
L601 and C103	af filter

## 25. Local Audio Channel

(fig. 12)

The local audio channel consists of two stages of amplification. First stage V602A

amplifies the signal from an amplifier V601 and applies this signal to local at output stage V603. The output tube increases the audio signal from the local af amplifier to a suitable level for operating a loudspeaker or a headset. Degenerative feedback is used to obtain the necessary frequency response.

a. The signal voltage from V601A is developed across LOCAL GAIN potentiometer R104. Part of this voltage, depending on the setting of R104, is applied to the control grid of V602. The amplified signal is coupled to the control grid of V603 through C603. The output of V603 is developed across the primary of T602. The signal across the secondary is applied across series-connected resistors R127 and R128. The signal voltage across R127 and R128 is applied to terminals 6 and 7 of TB102. These terminals are normally connected to a loudspeaker. The signal voltage across R128, available at terminals 7 and 8, is normally connected to a headset.

b. Distortion is reduced by degeneration in the cathode circuit of V603A produced by signal voltage across cathode bias resistor R604. To improve frequency response, a feedback voltage is coupled from the plate of V603, through R606, to the cathode

c. The functions of the remaining parts are listed below.

Part	Function
R605	Plate load resistor for V602A.
R607	Grid return resistor for V603.
R608	Cathode bias resistor for V603.
C604	Controls frequency response of T602.

## 26. Line Audio Channel

(fig.4)

The audio channel is similar to the local audio channel (para 25) but is designed to work into a output level can be monitored with LINE LEVEL meter M101.

a. The inner ends of the secondary halves of transformer T603 are connected to terminals 11 and 12 of TB102 (TM 11-5820-357-20). A jumper is normally connected between these terminals, except when an external balancing network is used to correct the impedance. The signal developed across the entire secondary (Terminals 3 and 6) to T603 is connected to terminals 10 and 13 of TB101, as well as to terminals A and J of REMOTE CONTROL

connector J105, when BREADIN switch S106 is in the OFF position. Resistors R112 through R116 form a pad that attenuates the signal 14 decibels (db) to a level suitable for transmission over a 600-ohm balanced line.

b. LINE LEVEL meter M101 is connected across the output-transformer secondary to indicate the level of the balanced-line signal. This meter is calibrated in volume units (vu). The face of the meter has two scales: the upper scale is calibrated to read directly in vu when LINE METER switch S101 is set to O vu; the lower scale is calibrated from 0 to 100, ending at a point opposite O vu on the upper scale. Meter M101 has an impedance of 3,900 ohms. Resistor R101 is connected in series with M101 to match its impedance of 3,900 ohms. Resistor R101 is connected in series with M101 to match its impedance to the amplifier output circuit.. To change the range of the meter, switch S101 selects one of two pads, or connects the meter and R101 directly to the circuit. For the -10-vu range, the connection is direct; for the 0-vu range, a pad that consists of R117 through R119 is used; and for the +10 vu range, a pad that consists of R120 through R122 is used. Pads are used as range

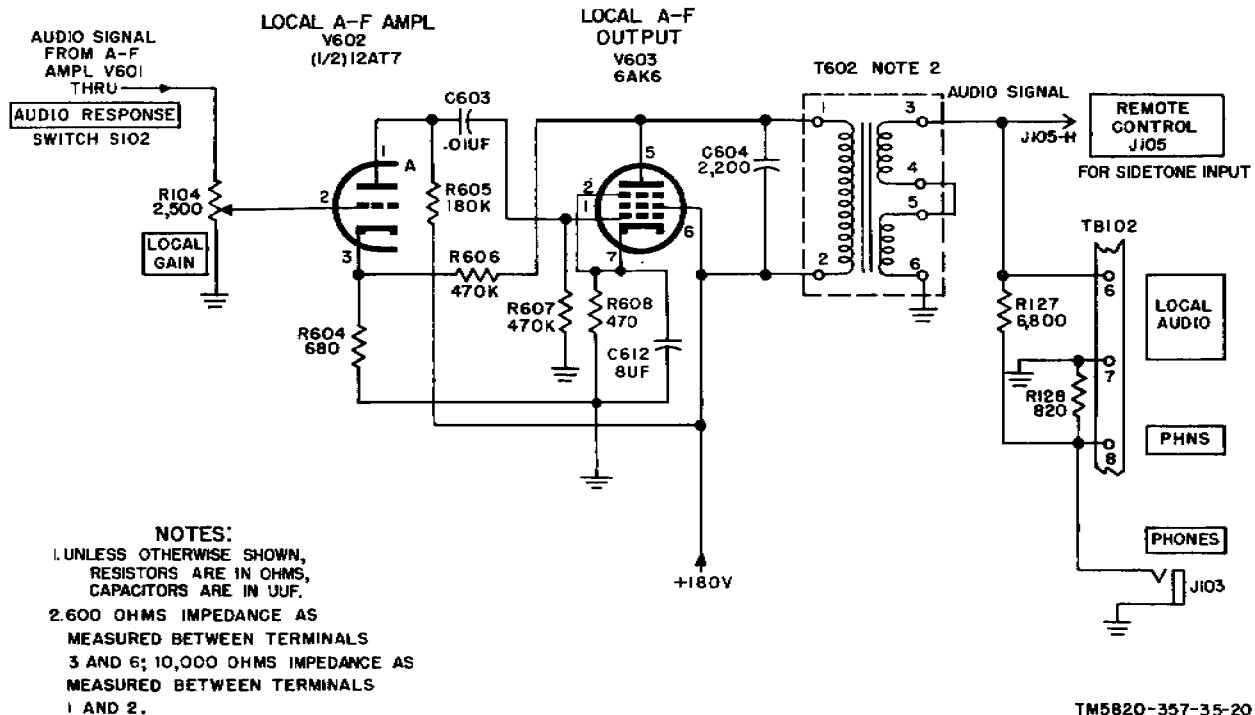

Figure 12. Local audio, simplified schematic diagram.

multipliers and to maintain the impedance match. A fourth position of switch S101, OFF, disconnects the meter, from the circuit and substitutes R102 in its place to maintain the impedance match required across the secondary winding of T603.

c. The functions of the remaining parts are listed below.

Parts	Function
R103	LINE GAIN potentiometer.
R628 and R632	Cathode bias resistors.
R629	Plate load resistor for V602B.
R631	Grid return resistor for V604.
R633	Common cathode bias resistor.
R634 and C609	Plate decoupling network for V602.
C610	Coupling capacitor.
C611	Controls frequency response of T603.

## 27. Squelch Circuit V601

(fig. 13)

When FUNCTION switch S107 is in the SQUELCH position, the squelch circuit disables the audio output during periods of no transmission by the transmitters to which the receiver is tuned. In addition, an associated transmitter can be disabled when the operator of a distant station wishes to interrupt a transmission (break-in operation).

a. When no signal is being received, the only bias applied to the control-grid circuit of V601 is that applied to the cathode from the voltage divider composed of R612 and R613. Plate current flows through the coil of squelch relay K601, energizing it. Contacts 1 and 2 of relay make, grounding the high side of audio transformer T601.

b. When a carrier signal is received, a voltage is developed across R539 and R540 (part of the diode detector load), with a polarity as indicated in figure 13. This voltage, filtered by R610 and C605, adds enough bias to the control-grid circuit to lower plate current to a point where the coil of K601 becomes sufficiently deenergized to release the armature; the circuit between contacts 1 and 2 breaks and the audio output at T601 is restored.

c. When FUNCTION switch S107 is in any position other than SQUELCH, B+ voltage is not applied to the plate circuit of V601; the tube is inoperative.

d For break-in operation of radio set,

completed between pin K of REMOTE CONTROL connector J105 and ground through contacts 4 and 5 of FUNCTION switch S107 rear (when it is in the SQUELCH

position), contacts 5 and 6 of BREAK IN switch S106 (when it is in the OFF position), end contacts 1 and 3 of squelch relay K601 (when it is deenergized). When a signal is received, contacts 1 and 3 of K601 break, opening the ground circuit and thus disabling the associated transmitter.

## 28. Calibration Oscillator V901A

(fig. 14)

Calibration oscillator V901A, a Pierce crystal oscillator, supplies a 1-me signal for synchronizing multivibrator V902.

a. The oscillating voltage produced by crystal Y901 is applied between the control grid and the plate of the tube. Capacitor C904 blocks the application of the dc plate voltage to the crystal.

b. The parallel combination of C901 and C903, the former being adjustable, permits small adjustment of the oscillator frequency. In addition, with R901, the combination develops grid leak bias for the stage.

c. Coil L903 is the plate load; it is grounded for rf through C914. Other elements of the plate circuit are dropping resistor R902 and plate-circuit decoupling network L902 and C907. Capacitor C905 completes the rf circuit from plate to cathode.

d. Plate voltage is applied to the stage only when FUNCTION switch S107 is in the CAL position. This is also true for the following stages in the calibrating system; multivibrator V902 and buffer amplifier V901 B

## 29. Multivibrator V902

(fig. 15)

Multivibrator V902 oscillates at a fundamental frequency of 100 kc. Synchronized by calibration oscillator V901A, it provides a secondary frequency standard for calibrating the receiver at every 100-kc point throughout its frequency range.

a. When FUNCTION switch S107 is in the CAL position, B+ voltage is applied to the

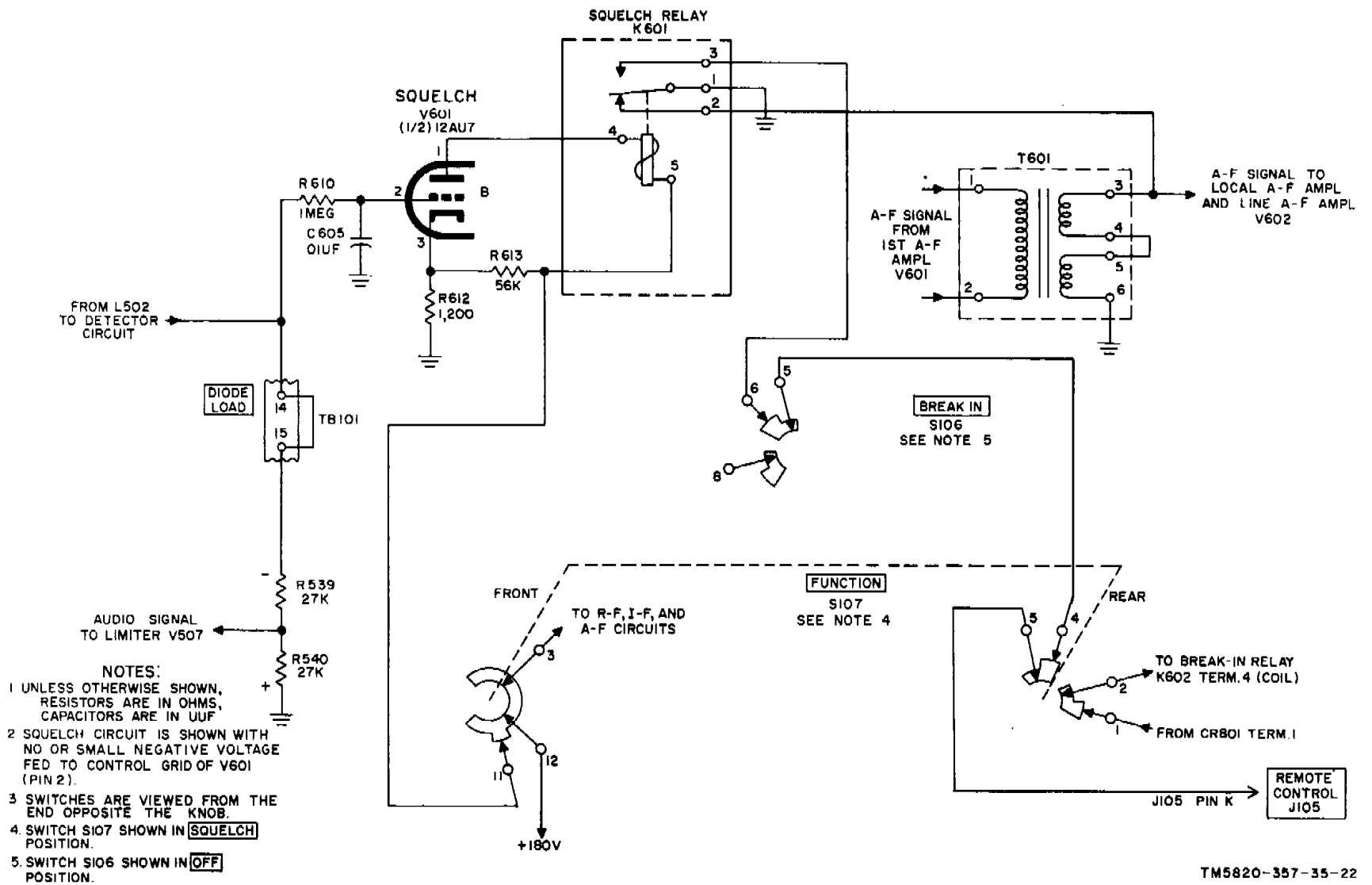

TM5820-357-35-22

Figure 13. Squelch circuit, simplified schematic diagram.

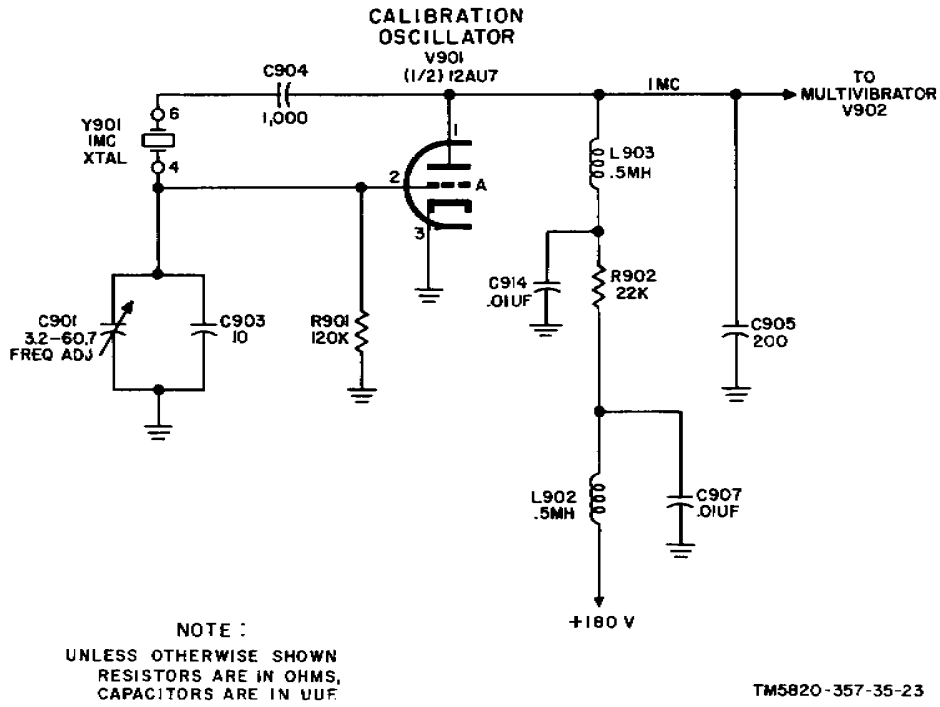

Figure 14. Calibration oscillator, simplified schematic diagram.

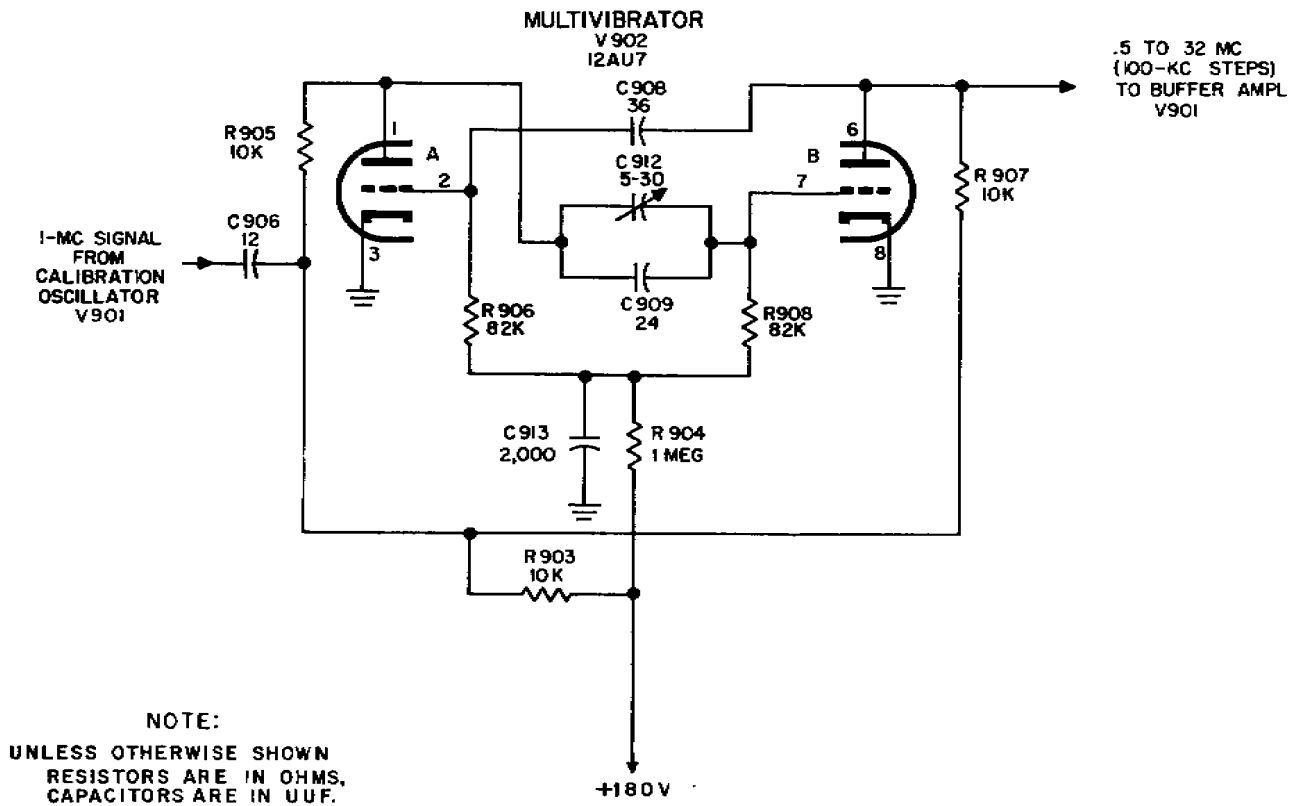

Figure 15. Multivibrator, simplified schematic diagram.

plates through dropping resistor R903 and through plate load resistors R905 and R907. B+ voltage also is applied to the control grids through dropping resistor R904 and grid resistor R906 and R908.

b. The free-running frequency of the oscillator, without synchronization, is determined by the time constants of R906 and C908 (for section A of the tube) and R908, C909, and C912 (for section B). Capacitor C912 is made adjustable so that the stage can be synchronized exactly at 100 kc by calibration oscillator V901A.

(fig. 16)

The buffer amplifier isolates the multivibrator from the first rf amplifier.

a. The 100-kc signal from the multivibrator is applied through C910 to the buffer-amplifier control grid. The output from the plate circuit is applied to the control grid circuit of first rf amplifier V201. Plate voltage is applied through coil L901 and resistor R910, which form the plate load.

b. Resistor R911 is the grid return resistor. Cathode bias is provided by R909 and C911.

### 30. Buffer Amplifier V901B

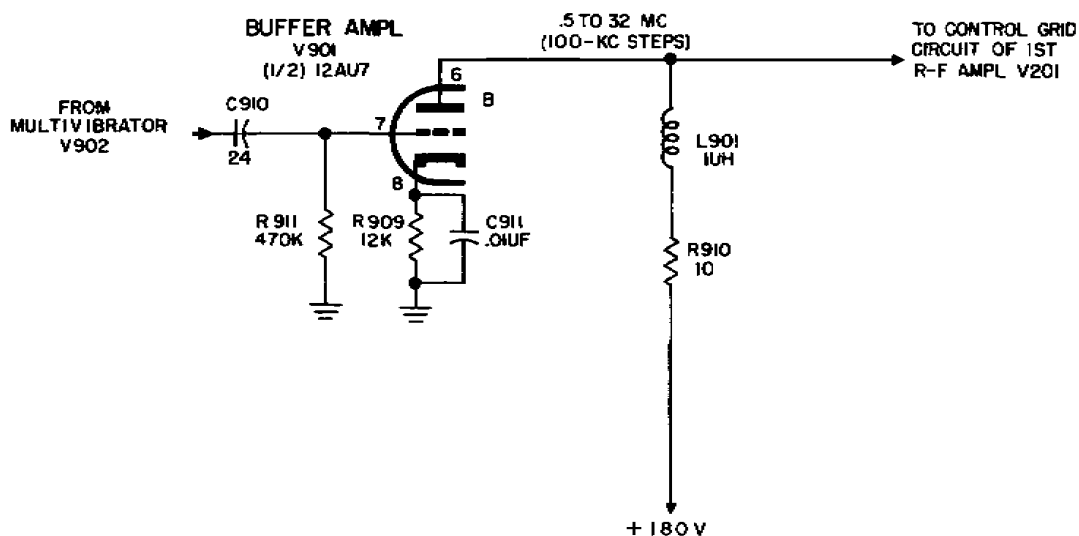

TM5820-357-35-25

Figure 16. Buffer amplifier, simplifies schematic diagram.

## Section III. THEORY OF POWER SUPPLY PP-621/URR, VOLTAGE REGULATOR, FILAMENT CIRCUITS, AND OVEN-HEATED CIRCUITS

### 31. Power Supply PP-621/URR

(fig. 65)

The PP-621/URR supplies 300 volts, unregulated dc to the voltage regulator circuits, 6 volts dc to the relay circuits (para 37), and 25.2 volts ac to the filament and oven-heated circuits.

a. The primary windings of T801 are connected, through line filter FL101, 3-ampere ac fuse F101, S801, and S701 to terminals A and D of power receptacle J104. Each side of the ac line is filter by FL101 to minimize noise pickup and interference

from external sources. Two separate primary windings in T801 permit selection, through S801 permit selection, through S801, of either 115- or 230- volt operation. For 115-volt operation, S801 connects the two primary windings in parallel; for 230-volt operation, S801 connects the two windings in series.

b. Terminals 5 and 7 of the high-voltage secondary of T8-1 are connected to the plates of rectifiers V801 and V802 are duodiodes connected as diodes in a full-wave rectifier circuit. Each cathode has a protective resistor. These

resistors (R801 through R804) limit the current through each diode. The high-voltage dc output is filtered by C 101 before being applied to the voltage regulator circuits.

c. The low-voltage secondary (terminals 8 and 10) of T801 supplies 25.2 volts ac to all filament, dial lamps, and oven-heater circuits. A tap (terminal 9) on this winding provides 12 volts for dry-disk rectifier CR801, to supply 6 volts dc to antenna relay K101 and break-in rev K602.

### 32. Voltage Regulator

(fig. 17)

The voltage regulator supplies B+ voltage to all stages. The B+ voltage is nearly constant regardless of changes in load current or input voltages.

a. The output from the PP-621/URR is applied to the voltage regulator circuit. Voltage regulators V605 and V606 function as variable series resistance to regulate the dc output voltage. Tube V607 functions as a dc amplifier and controls the series resistance of V605 and V606 in accordance with voltage variations in the power supply or in the receiver B+ circuits. Two cold-cathode tubes, V608 and V609, provide a constant reference of +180 volts for dc amplifier V607. The regulated output from the voltage regulator is applied to the plate and screen grids of the receiver (para 35).

b. The four plates of V605 and V606 are tied together and connected directly to the unregulated dc voltage. The four cathodes are connected in parallel by resistors R619, R620, R621, and R622. These resistors assure load current balance. The voltage that appears at the cathodes is determined by the voltage drop across the tube resistance, which is controlled by the bias applied to the control grids. If either the unregulated or the regulated voltage changes, V607 will alter the bias voltage, and the resistance of the regulators will change in a direction to restore the correct voltage. Voltage reference tubes V608 and V609 and resistors R625 and R626 are connected across the voltage-regulated output circuit. The voltage drop that appears across R626 is applied to the control grid circuit of dc amplifier V607 through isolating resistor R624.

c. A change in the drop across R626 produces a change in the plate current of V607. Voltage variations are produced across potentiometer R614 and resistor R615, the plate-load for the tube. These varying voltages are fed to the control grids of V605 and V606. If the voltage at the control grid of V607 increases, the plate voltage will decrease. This condition produces a less positive voltage on the grids of V605 and V606, and increases the apparent resistance and voltage drop of the tubes. The output voltage from the cathode circuit of V605 and V606 will decrease in proportion to the increase in positive bias fed to the dc amplifier control grid. This action is reversed when the load current decreases. A nearly constant output voltage is produced, which minimizes variations caused by line voltage or B+ circuit changes.

d. Resistors R623 and R618 form a voltage divider across the output of the voltage regulator. The voltage appearing across R618, as increased by cathode current flow, provides cathode bias for V607. Capacitor C606 bypasses R618.

e. Screen-grid voltage is taken from the junction of R616 and R617, a voltage divider across the unregulated input.

f. HUM BAL control R614 permits presetting the amount of the ripple component of the voltage fed back to the control grids of V605 and V606, thus minimizing hum in the output. The ripple component is coupled to the control grid of V607 by C608.

g. Resistor R627 provides starting voltage for V608 and V609.

### 33 Filament and Dial Lamp Circuits

(fig. 66)

Filament voltages of 6.3, 12.6, and 25.2 volts ac are required. Dial lamps DS101 and DS108 and filaments requiring 25.2 volts are connected in parallel with the 25.2-volt secondary of T801. Filaments requiring 6.3 or 12.6 volts are connected in series.

a. The various choke coils in series with the filaments, together with their bypass capacitors, prevent interstage coupling of high-frequency signals through the filament circuits.

b. The filament voltage across V401, V402,

- NOTES:  
 1. UNLESS OTHERWISE SHOWN, RESISTORS ARE IN OHMS, CAPACITORS ARE IN UUF.  
 2. SWITCHES ARE VIEWED FROM THE END OPPOSITE THE KNOB.  
 3. SWITCH S107 IS IN **AGC** POSITION.

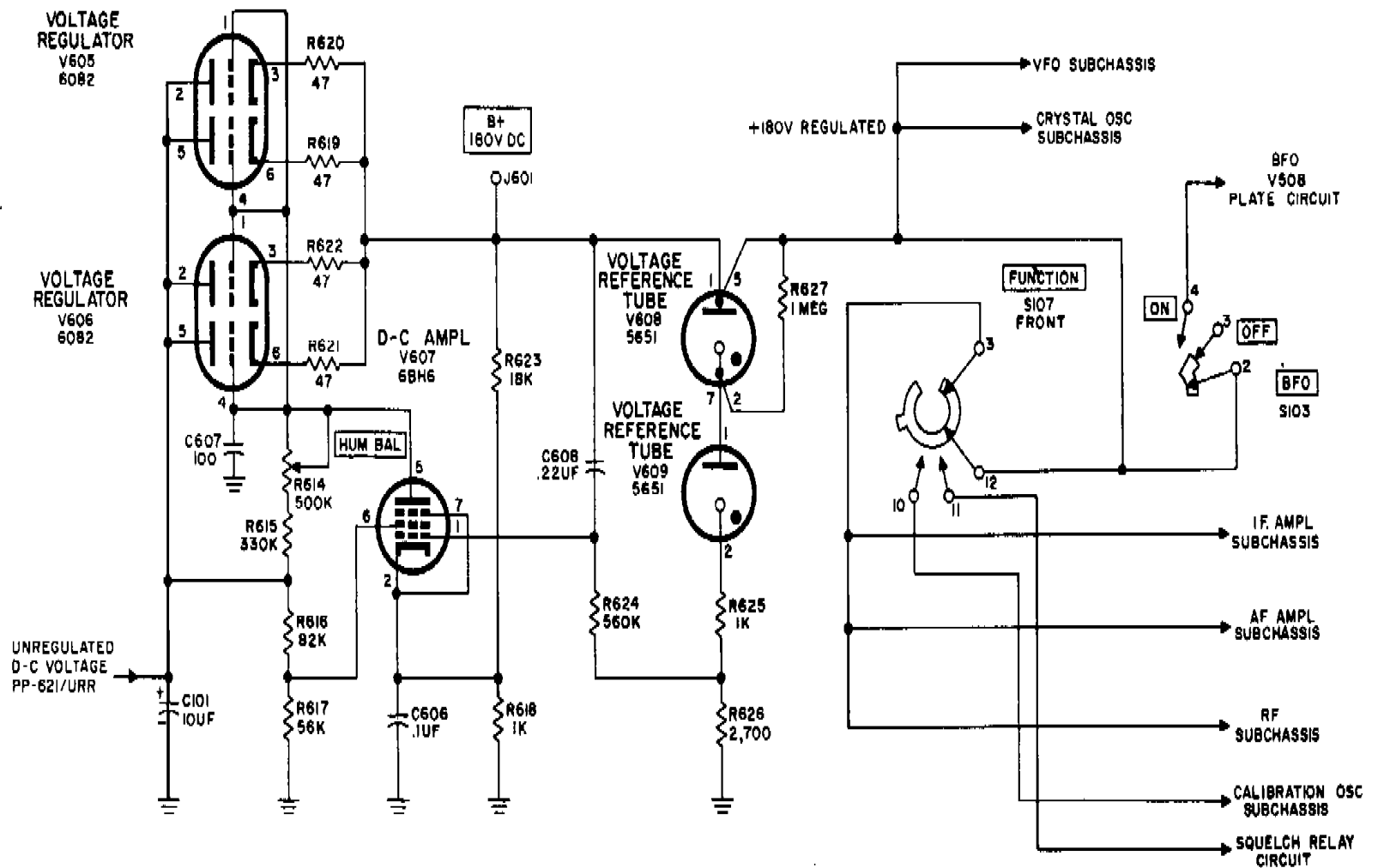

TM5820-357-35-27

TM5820-357-35-27

Figure 17. Voltage regulator, simplifies schematic diagram.

and V201 is limited to 18 volts by R411. To maintain constant voltage, voltage regulator tube RT512 is connected in series with the filaments of V701 and V508. Resistor R635, in series with the filament circuit of V601 and V602, reduces hum in the audio subchassis by reducing the filament current.

### 34. Oven-Heater Circuits

(fig. 66)

- a. When OVENS switch S108 is set to ON, 25.2 volts ac is applied to crystal oscillator oven HR401 and vfo oven HR701; 25.2 volts ac is applied to calibration oscillator oven HR901 at all times.
- b. The ovens are thermostatically controlled by switches S405 and S701, in the crystal oscillator and vfo oven circuits respectively, and by the unmarked switch in the calibration oscillator oven circuit.
- c. To prevent electrical interference caused by arcing at the contacts of the thermostatic switches, capacitors C434, C435, C710, C711, and C902 and coil L705 are used.

### 35 Voltage Distribution (B+)

(fig. 17)

FUNCTION switch S107, controls the application of B+ to all plate and screen grid circuits except the first and second crystal oscillators and the vfo.

These circuits are always connected to B+ to keep the temperature of the components constant.

- a. When the FUNCTION switch is in the MGC and AGC positions, regulated B+ voltage is applied to all circuits except the calibration oscillator and the squelch circuit.
- b. When the switch is in the CAL position, the plate circuit of the calibration oscillator is energized, and the dc output of rectifier CR801 (fig. 74) is applied to the antenna relay.
- c. When the switch is in the SQUELCH position, B+ is connected to the plate circuit of squelch tube V601B in addition to other receiving circuits.
- d. When the switch is in the STAND BY position, all B+ circuits (except those of the oscillators) are disabled, and no voltage is applied to the antenna relay to ground the antenna input circuit.

### 36. FUNCTION Switch S107

(fig. 18)

The FUNCTION switch performs switching operations that affect the entire operation of the receiver. The six positions of the FUNCTION switch are shown in figure 18; only circuits that are closed by the switch segments are identified. The chart below shows the circuits affected in each of the positions of the switch as related to the control knob indication.

Position	Switch contacts completed		Circuits
	Front	Rear	
OFF .....	None .....	None .....	Primary power is disconnected from the receiver (fig. 65). Primary power is applied to the receiver (fig. 65). Terminal 2 of CR801 is grounded to apply 6 volts do to antenna relay K101 which grounds the antenna input at J107 and J108. No voltage is applied to the rf, if., and at stages.
STAND BY	None .....	9 to 10	
AGC .....	12 to 3 .....	1 to 2 .....	volts do is applied through the front contacts to the rf, if., and at stages. Ago voltage at contact 7 of S107 (rear) is not grounded. Ground is removed from terminal 2 of CR801 and causes energizing voltage to be removed from antenna relay K101. Contacts 1 and 2 of S107 (rear) connect terminal 1 of CR801 to terminal 4 (coil) of break-in relay K602. Break-in operation is possible (para 37).
MGC .....	12 to 3 .....	2 to 3, 7 to 8	The conditions for MGC are the same as for AGC, except the ago bus is grounded through contact 7 of S107 (rear).
CAL .....	12 to 3, 12 to 10	8 to 9 .....	volts do is applied to the rf, if., at, and calibration oscillator stages. Terminal 2 of CR801 is grounded to apply 6 volts do to relay K101 which grounds the antenna input at J107 and J108.
SQUELCH	12 to 3, 12 to 11	1 to 2, 4 to 5	The conditions for SQUELCH are the same as for AGC, except +180 volts dc is applied to V601. Carrier control circuit is made available (para 37).

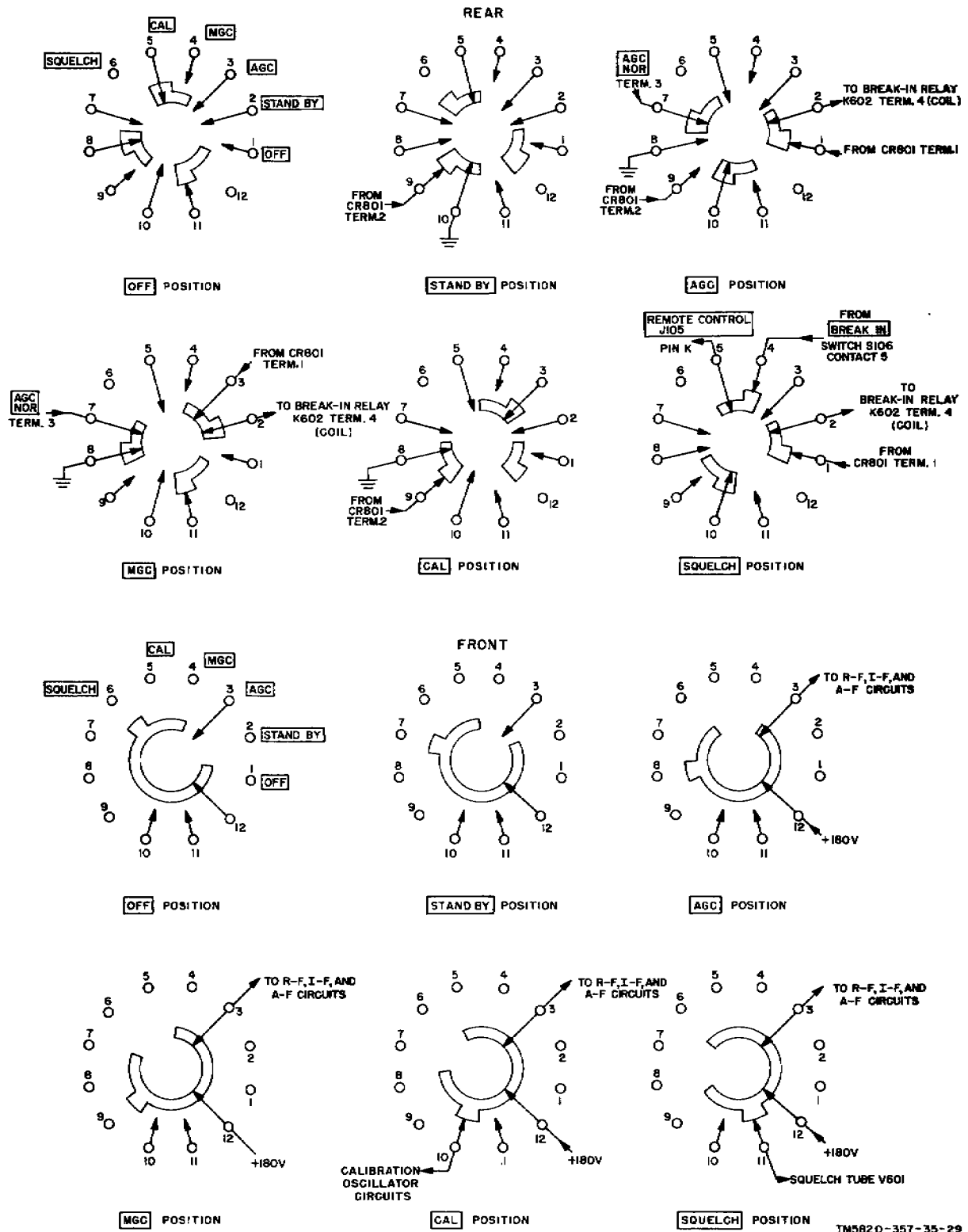

TN5820-357-35-29

Figure 18. FUNCTION switch, switching arrangement.

### 37. Control Circuits (Break-In)

(fig. 67)

When the receiver is used with a transmitter, certain receiver circuits must be disabled during transmission to prevent receiver damage.

a. When FUNCTION switch S107 is set to STAND BY, segment 2 is across terminals 9 and 10, and ground is connected to terminal 2 of rectifier CR801, which energizes antenna relay K101. The movable contacts of K101 are connected to ground, and the contacts short-circuit the antenna input at J107 and J108.

b. When the FUNCTION switch is in the CAL position, the rf input is shorted to ground as described in a above, except that segment 1 is across terminals 8 and 9. This condition prevents rf signals from entering the receiver and interfering with the output of the calibration oscillator.

c. When the FUNCTION switch is in the AGC, MGC, or SQUELCH position, the coil of relay K602 is in parallel with the coil of K101. When ground connection is applied, by means of auxiliary

equipment, to terminal 9 of TB101 or terminal B of REMOTE CONTROL J105 and BREAK IN switch S106 is turned to ON, segment 3 of S106 is across terminals 8 and 10; this action causes K101 and break-in relay K602 to energize. The antenna input and the af amplifier output are short-circuited to ground.

d. When the B REAK IN switch is in the OFF position, line audio output is applied to terminals A and J of REMOTE CONTROL connector J105.

e. For carrier control operation, S107 must be set to SQUELCH and S106 to OFF. The carrier control line is terminated at K of REMOTE CONTROL, connector J105 and completed to ground through contacts 4 and 5 of S107, contacts 5 and 6 of S106, and contacts 1 and 3 of K601. When S106 is in the ON position, the carrier control line is disabled by opening the lead from contact 3 of K601. When K601 is energized, the carrier control line is disabled by opening contacts 1 and 3.

## Section IV. ANALYSIS OF MECHANICAL TUNING SYSTEM

### 38. General Principles of Operation

(fig. 19)

The mechanical tuning system of the receiver controls the permeability tuning and switching elements to provide continuous tuning over a range of 0.5 to 32 mc in 32 steps. Each step is tuned over a range of 1 me except for the first step, which is tuned from 0.5 to 1 me. The frequency selected is shown on a counter type dial.

a. Operation of the MEGACYCLE CHANGE and KILOCYCLE CHANGE knobs is limited to 10 turns by progressive mechanical stops. As the MEGACYCLE CHANGE knob is turned, the first variable i£ is varied within the range of 9 to 18 me for the incoming signal range of 0.5 to 8mc. On the other ranges, although the slug racks are moved, this circuit is disabled. The MEGACYCLE CHANGE control also operates the 32-position switches in the first and second crystal oscillators and, through the

Geneva system and the over-travel coupler, operates the six-position rf band switch. The starting point from which a given slug rack is moved by the KILOCYCLE CHANGE control is established, through the differential, by the MEGACYCLE CHANGE control. The slug racks affected are those that control the frequency ranges of 16 to 32 me, 8 to 16 mc 4 to 8 mc and 2 to 4 me.

b. The KILOCYCLE CHANGE knob is connected through a 10-turn stop to the vfo and through the gear train to the antenna, rf amplifier second variable if. slug racks, and the first variable if. cam rack. The KILOCYCLE CHANGE knob is also connected to the same differential as the MEGACYCLE CHANGE knob. The KILOCYCLE CHANGE knob provides movement of the

slug racks in the four bands (a above) from the starting point established by the MEGACYCLE CHANGE knob. A ZERO ADJ. knob on the front panel permits correction, over a small range, for differences between the reading on the counter and the mechanical and electrical tuning system.

### 39. Functional Analysis

a. The MEGACYCLE CHANGE control performs the following functions:

- (1) Through direct-drive gears, it operates the first variable i.f. slug rack and the 32-position switches in the first and second crystal oscillators.
- (2) Through the differential, it sets the proper positions of the rf slug racks for the four highest bands at each of its 32 positions.

(3) Through the Geneva system and overtravel coupler, it operates the rf band switches. These switches are turned only when tuning the receiver requires switching to a new rf band.

b. The KILOCYCLE CHANGE control performs the following functions:

- (1) Without gearing, it drives the shaft of the vfo.
- (2) Through direct-drive gears, it operates the second variable i.f. slug rack, the first variable i.f. can rack, and the rf slug racks for the two lowest rf bands.
- (3) Through the differential, it operates the rf slug racks for the four highest bands; the same that are preset by the MEGACYCLE CHANGE control (a(2) above).

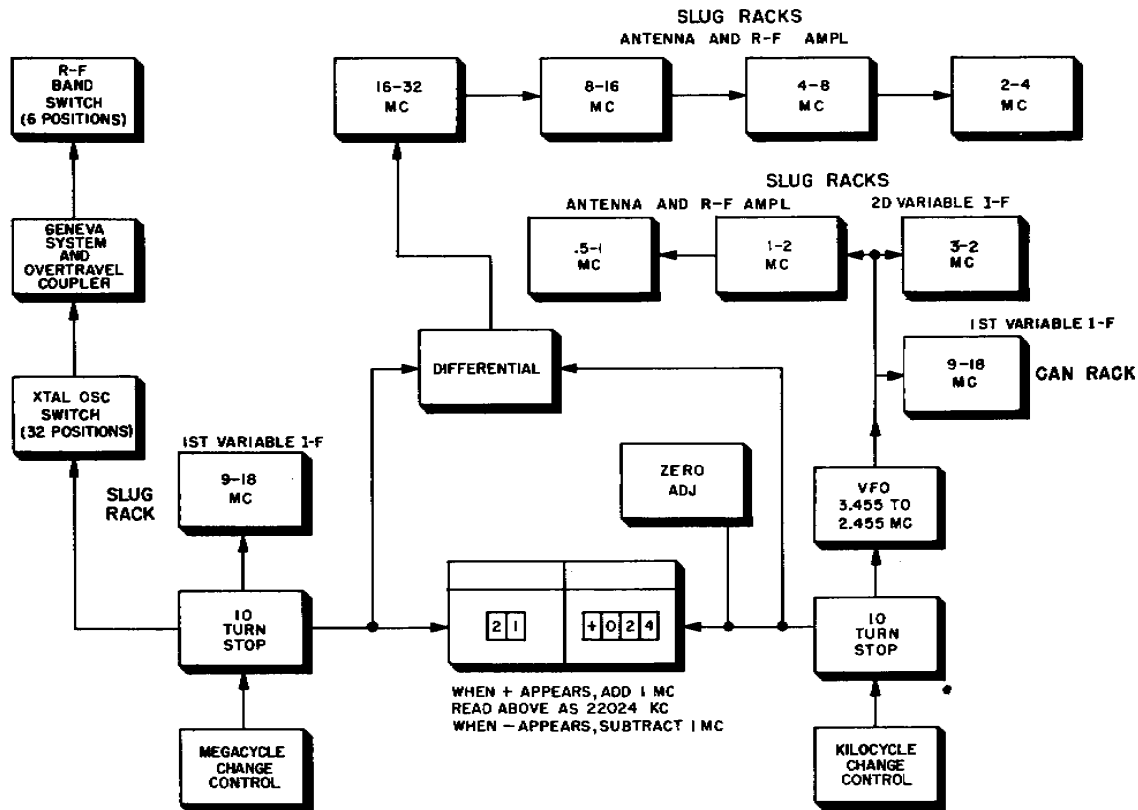

TM5820-357-35-31

Figure 19. Mechanical tuning system, block diagram.

*Note:* The first variable if. cans are mounted on a rack,(can rack), that is moved during tuning to preserve alignment of these circuits.

#### 40. Mechanical Tuning, Detailed Analysis

(fig. 68)

In figure 68, each gear in the gear train is shown as a disk, identified by a letter designation and bearing a number to indicate the number of teeth.

Although, in the receiver, all slug racks are operated at both ends by cams, only one cam per slug rack is shown for simplicity. Both MEGACYCLE CHANGE AND KILOCYCLE CHANGE are limited to 10 turns by progressive ring stops.

##### a. MEGACYCLE CHANGE Control.

- (1) The MEGACYCLE CHANGE control operates the first variable if. Slug rack through gears A, B, C, D, E, F, and G. The shaft on which gears E and F are mounted operates the 32-position crystal oscillator switches through an Oldham coupler and through gears H and J. The Oldham coupler corrects for slight mechanical misalignment of the shafts.
- (2) Gear K, mounted on the same shaft as gears E and F, transfers motion to the 6-position rf band switches through the Geneva system (gear L and lost-motion gear GGG) and gears M, N, and P. Gear L turns continuously as the MEGACYCLE CHANGE control is turned; gear GGG is effective in driving gears M, N, and P only when it is time for a change in the position of the rf band change switches.
- (3) In addition to driving gear G, gear F transmits motion to the megacycle counter wheels through gears RR, SS, TT, UU, VV, WW, and XX.
- (4) The 2- to 4-mc, 4- to 8 mc, 8- to 16-me, and 16- to 32-mc rf slug racks are moved by both the MEGACYCLE CHANGE and KILOCYCLE CHANGE controls through the differential gear system. The 2-to4-mc slug rack is positioned by the MEGACYCLE CHANGE control through gears A, B, Q, R,

S, and T. Motion is continued through gears U and V to position the 4- to 8-mc rack, through gears Wand X for the 8-to 16-mc rack, and through gears Y and Z for the 16- to 32-mc rack.

- (5) An exact stopping position for each of the 32 steps of the MEGACYCLE CHANGE control is provided by the megacycle change detent. Driven by gear B, it is a disk with three equally spaced notches in its edge. A spring bracket, pressed against the edge, slips into each notch as the disk turns, providing an effective stop.
- ##### b. KILOCYCLE CHANGE Control.
- (1) The KILOCYCLE CHANGE control turns the shaft of the vfo tuning unit directly through an Oldham coupler.
  - (2) Gears BB, CC, DD, EE, and FF transmit motion to the second variable if. slug rack and to the first variable if. can rack.
  - (3) Motion to the differential gear system (a(4) above) is transmitted through gears BB, CC, GG, HH, PP, and QQ. Gear HH also drives the 0.5- to 1-me slug rack through gears JJ, KK, and LL. Motion is continued through gears MM and NN to drive the 1- to 2-mc rf slug rack.
  - (4) Gears EKE and FFF are turned by gear HH. During operation, gear EKE is not engaged with DDD. Before disassembly of the gear train, these two gears are engaged by the repairman to prevent loss of mechanical synchronization, through the differential system, between the MEGACYCLE CHANGE and KILOCYCLE CHANGE controls.
  - (5) To turn the kilocycle counter wheels, motion is picked off gear AA and transmitted through gears YY, ZZ. AAA, BBB, and CCC. Gear ZZ acts as a clutch, controlled by the ZERO ADJ. knob. When disengaged from YY, it permits setting the kilocycle counterwheels at exactly the frequency to which the receiver is tuned, without affecting the gear train.

## CHAPTER 2

### THIRD ECHELON MAINTENANCE

#### Section I. GENERAL TROUBLESHOOTING TECHNIQUES

**Warning:** When servicing the receiver, be careful when working on or near the high voltage circuits. Unless voltage measurements are being taken, be sure that the FUNCTION switch is OFF and that the power cord is disconnected from the power source.

#### 41. General

The field and depot maintenance procedures in this manual *supplement* the organizational maintenance procedures (TM 11-6820-357-20). The systematic troubleshooting procedure, which begins with the operational and sectionalization checks that can be performed at an organizational level, is carried to a higher level in this manual. Sectionalizing, localizing, and isolating techniques used in the troubleshooting procedures are more advanced.

#### 42. Organization of Troubleshooting Procedures

*a. General.* The first step in servicing a defective receiver is to sectionalize the fault.

Sectionalization consists of tracing the fault to a subchassis responsible for the abnormal operation of the receiver. The second step is to localize the fault. Localization means tracing the fault to the malfunctioning circuit in the subchassis. Finally, the defective part is isolated by voltage and resistance measurements.

*b. Sectionalization.* Listed below is a group of tests arranged to help locate the defect to a subchassis.

- (1) *Visual inspection.* The purpose of visual inspection (para 45) is to locate faults without circuit tests or measurements.
- (2) *Operational tests.* Operational tests (para 44) frequently indicate the general location of trouble. In many instances, the tests will help to determine the exact nature of the fault.
- (3) *Checking plate and filament circuits for shorts.* These measurements (para 46) prevent further damage to the receiver from possible short circuits.

*c. Localization.* The charts and tests listed below will help locate the defective circuit.

- (1) *Troubleshooting chart.* The troubleshooting chart (para 49c) presents a systematic method of locating malfunctioning circuits.

(2) *Signal substitution.* Signal substitution (para 50), when used in conjunction with the troubleshooting chart, provides a method of localizing trouble to a stage.

(3) *Stage-gain charts.* The stage gain charts (para 52) are helpful in localizing obscure, hard-to-find troubles.

*d. Isolation.* The defective component is usually located by voltage and resistance measurements. Voltage and resistance charts (fig. 39, 72, and 73), and paragraph 54 will aid in locating the defective component. The resistor and capacitor color codes are given in figures 54 and 55.

*Note:* In all these tests, the possibility of intermittents should not be overlooked. This type of trouble may be made to appear by tapping or jarring the subchassis or parts under test. Check the wiring and connections to each subchassis.

#### 43. Test Equipment Required

The following charts list test equipment required for troubleshooting the receiver.

Test equipment	Technical manual
Electronic Multimeter TS-505(*)/U <sup>a</sup>	TM 11-5511 and TM 11-6625-239-12
Multimeter TS-352(*)/U <sup>b</sup>	TM 11-5527
RF Signal Generator Set AN/URM-25(*) <sup>c</sup>	TM 11-5551D or TM 11-5551E
Test Set, Electron Tube TV-7(*)/U <sup>d</sup>	TM 11-6625-274-12

<sup>a</sup> Indicates TS-505/U and TS-505A/U through TS-505D./D.

<sup>b</sup> Indicates TS-352/II, TS-352A.'I', and TS-352B/U.

<sup>c</sup> Indicates AN/URM-25D or AN/URM-25F.

<sup>d</sup> Indicates TV-7A/U, TV-7B/U, and TV-7D/U.

## Section II. TROUBLESHOOTING RECEIVER

### 44. Operational Tests

Operate the receiver as described in the equipment performance checklist (TM 11-5820-357-20). This checklist frequently aids in sectionalizing the trouble.

a. Observe the readings of the CARRIER LEVEL and LINE LEVEL meter usually indicates satisfactory operation of the age circuit and all stages up t and including the fifth if. Stage. If the LINE LEVEL meter reading is normal, satisfactory operation of the remaining stages, except for second as amplifier V602A, and the local audio channel output stage, V603, is indicated. To check these stages, listen to a 600-ohm headset, such as HS-30-U, or a loudspeaker such as LS-3.

b. To check the if. Local audio and stages, connect a headset to the PHONES jack on the front panel. Turn the FUNCTION switch to AGC. Start in at the BANDWIDTH switch 16 position, set the switch in turn to each lower position. If the volume of the rushing sound heard in the headset decreases

noticeably with each lower setting, the if. And local audio stages are probably operating. For a more detailed check, refer to paragraph 49.

c. The calibration oscillator can be used as a convenient means of quickly localizing trouble in the receiver.

- (1) To check the LINE LEVEL meter, LINE METER switch, and LINE GAIN control, perform the steps listed in the chart below. If the correct meter indications are not obtained, check the LINE LEVEL meter and the 10-decibel(db)pads (fig.40), the LINE METER switch, and the LINE GAIN control. Connect a headset to the PHONES jack and proceed as follows:

Step	Control	Adjustment	Indication
	KILOCYCLE CHANGE control - -- FUNCTION switch----- - BFO switch----- -- LINE METER switch----- LINE GAIN control	Set to even 100 kc on dial Set to CAL  Set to ON----- - Set to -10 Adjust to obtain 0 vu (upper scale) on LINE LEVEL meter.	Audible tone should be heard.
	LINE METER switch	Set to 0-----	Reading on LINE LEVEL meter should drop to -10 vu.
	LINE GAIN control	-- Set for 0 vu on LINE LEVEL meter.	
	LINE METER switch	Set to + 10	Reading on LINE LEVEL meter should drop to -10 vu.

d. To check the contacts of the rf band switch (S201 through S210, fig.22), set to the PHONES

jack on the front panel and connect a head

Step	Control	Adjustment	Indication
	FUNCTION switch ----- KILOCYCLE CHANGE ----- MEGACYCLE CHANGE ----- BFO PITCH -----	CAL. Any 100-kc position. Band 1. Turn clockwise or counter clockwise a few degrees.	A signal should be heard in headset.
	MEGACYCLE CHANGE -----	Turn to each successively higher band.	In every position, a signal should be heard in headset if not, trouble is indicated in the contacts of the rf band switch or the crystal-oscillator band switch, or there may be a defective crystal(TM 5820-357-20)

e. The synchronization of the tuning shafts can be quickly checked as follows:

Step	Control	Adjustment	Indication
1	MEGACYCLE CHANGE .....	Set to band 1.	Obtain a reading on the CARRIER LEVEL meter. CARRIER LEVEL meter reading should decrease. CARRIER LEVEL meter reading should decrease. CARRIER LEVEL meter reading should decrease. If the CARRIER LEVEL meter reading increases, the camshaft is out of synchronization. Refer to paragraph 73 for synchronization procedures.
2	KILOCYCLE CHANGE.....	Set so the frequency indicator has the first two digits as zeros and the last three digits are an even multiples of 100 kc.	
3	FUNCTION switch.....	Set to CAL.	
4	RF GAIN .....	Turn counterclockwise.	
5	5- to 1-me slug rack.....	Raise slug rack (fig. 41) slightly, using only light finger pressure.	
6	5- to 1-mc.....	Depress slug rack slightly, using only light finger pressure.	
7	Remaining slug racks.....	Repeat procedures described in 2 through 6 above for each slug rack, setting the frequency indicator dial at a reading within the band covered by the slug rack being checked.	

**45. Visual Inspection**

When a receiver is brought in for repair, remove the top and bottom dust covers and inspect as follows:

- a. Check to see that all connectors are seated properly. Repair or replace any connectors or cables that are broken or otherwise defective.
- b. See that all tubes are in their correct socket positions as shown in the tube location diagrams (TM 11-5820-357-20). Replace or interchange tubes that are not of the type called for in the tube location diagrams
- c. Inspect fuses and replace if necessary with fuses of correct rating and type. Whenever a blown fuse is found, check for short circuits (pare 46).
- d. See that the MEGACYCLE CHANGE and KILOCYCLE CHANGE controls turn freely. Rough operation or binding indicates a damaged tuning system or need for cleaning and lubrication (TM 11-5820-357-20).
- e. Check all switches and controls for ease of operation.

**46. Checking Filament and B+ Circuits for Shorts**

a. *When to Check.* When any of the following conditions exist, check for short circuits and clear the troubles before applying power.

- (1) The receiver is being serviced and the nature of the abnormal symptoms is not known.
- (2) Abnormal symptoms reported from operational tests indicate possible power supply troubles.

b. *Conditions for Tests.* To prepare for the short-circuit tests, proceed as follows:

- (1) Disconnect the receiver from the power source.
- (2) Remove the dust covers.

c. *Measurements.* Make the resistance measurements indicated in the chart below. If abnormal results are obtained, make the additional isolating checks outlined. When the faulty part is found, repair the trouble before applying the power to the receiver.

Point of measurement	Normal indication	Isolating procedure
Between chassis and pin 2 or 5 of V605 and V606.	140 000 ohms .....	If resistance is low, check filter capacitors C101 and C607 for short circuit or leakage.

Point of measurement	Normal indication	Isolating procedure
Between chassis and B+ 180V jack J601.	19,000 ohms with FUNCTION switch at OFF. 9,400 ohms with FUNCTION switch at AGC, MGC, or CAL. 8,500 ohms with FUNCTION switch at SQUELCH.	If resistance is high or infinite, check for an open circuit. If resistance is low, check for a short circuited by passing capacitor or for a short circuit in the wiring of one of the plate or screen grid circuits of an individual sum chassis ( <i>d</i> below).
<i>d. Locating a Short Circuit.</i> If the tests out-lined in <i>c</i> above indicate that there is a short circuit in the		receiver, determine in which subchassis it is located as follows:
Step	Procedure	Indication
1	Connect ground to receiver.	If the H.V. 3/8A fuse F102 blows after the power cable is connected to a subchassis, a short is indicated in that particular subchassis (para 49).
2	Set FUNCTION switch to OFF.	
3	Disconnect all interconnecting cables from the subchassis	
4	Replace any blown fuses.	
5	Check to see that the 115/230v switch on Power Supply PP-621/URR is in the proper position.	
6	Turn FUNCTION switch to AGC.	
7	Reconnect (one at a time) the power cables to the individual subchassis in the following order: a. Power Supply PP- 621/URR. b. Af subchassis. c. If. subchassis with BFO switch in ON position. d. Vfo subchassis. e. Crystal-oscillator subchassis. f.. Rf subchassis. g. Crystal-calibrator subchassis with the FUNCTION switch in CAL position.	
<i>e. Checking Filament Circuits.</i> If the tests performed as instructed in the chart in <i>d</i> above		reveal no trouble, check the filament circuits as follows:
Step	Procedure	Indication
1	Connect all interconnecting cables.	A short in the low-voltage or filament circuits will cause repeated burning out of AC 3A fuse F101. A short circuit to ground in oven heaters HR401, HR701, and HR901, or dial lamp DS102 or Ds101 will seriously affect the low-voltage circuit. If an abnormal filament circuit is indicated, test the tubes (TM 11-5820-357-20).
2	Turn FUNCTION switch to AGC and check filament short in the low-voltage or filament circuits will	

#### 47. Test Setup

(fig. 69 and 70)

When a trouble has been sectionalized to a particular subchassis, a bench test of the faulty subchassis may be required to locate the trouble. Since the subchassis mounted in the receiver are not readily accessible, it may be necessary to remove the subchassis under test and connect them to the receiver circuits by extension cables. Directions for fabrication

of the extension cables are given in figures 69 and 70. The number and type of extension cables needed can be determined by use of the chart in *d* below.

a. To avoid removing a subchassis to inject a signal where no test jack is provided, remove the tube associated with the suspected stage and insert a tube-socket adapter into the tube socket. Replace the tube into the adapter.

b. The rf tuning coils and transformers on

the rf subchassis can be readily removed (para 66) to permit measurement of voltage or resistance at the socket contacts. If trouble is suspected in the rf subchassis, make all possible measurements before removing the rf subchassis because this removal of the subchassis is difficult and time-consuming.

c. To prepare a subchassis for bench testing, remove the subchassis from the receiver in accordance with the instructions given in paragraphs 57 through 67. *Avoid the possibility of disturbing the synchronization of the gear train in the rf subchassis, crystal-oscillator subchassis, and the VFO subchassis. Do not turn any gear or shaft.*

**48. Connection of Extension Cables**

When the particular subchassis has been removed from the main frame, connect the extension cables between the receiver and subchassis according to the chart below.

*Warning:* When the subchassis are operated outside the receiver, dangerous voltages are exposed at tube-socket pins and other points on the undersides of the chassis. An adequate ground should be connected to the receiver main frame and the subchassis being tested.

Subchassis	Cable No.	Connect between
Rf .....	1	P209-J109
	1	P210-J110
	1	P211-J211
	1	P223-P723
	1	P224-J924
	1	P225-J525
	1	P226-J526
	2	P221-J421
	2	P222-J222
	2	P214-P114
Af .....	3	J619-P119
	4	J620-P120
Ac power supply .....	5	J818-P118
Crystal oscillator.....	6	J413-P113
	1	J421-P221
	1	J422-P222
VFO .....	7	P715-J115
	1	P723-J223
Calibration oscillator..	7	P916-J116
	1	J924-P224

Subchassis	Cable No.	Connect between
If.....	1	J512-P112
	1	J525-P225
	1	J526-P226
	8	J517-P117

**49. Localizing Troubles**

*a General.* The troubleshooting chart in c below supplements the operational checks detailed in the equipment performance checklist in TM 11-5820-357-20. The procedures outlined in the troubleshooting chart will aid in localizing troubles to a stage within a subchassis. If previous operational checks have resulted in reference to a particular item on the chart, go directly to the referenced item. If operational symptoms are not known or there is an indication of a short circuit, perform the short circuit tests described in paragraph 46 before applying power to the receiver. If no short circuits exist, begin with item 1 of Me equipment performance checklist and proceed until the trouble is located. Depending on the nature of the operational symptoms, one or more of the localizing steps will be necessary. When use of the procedures results in localization of trouble to a particular stage, use the techniques outlined in paragraph 53 to isolate the trouble to a particular part.

*b. Precautions.* Before proceeding to localize the trouble, observe the following precautions:

- (1) Connect an adequate ground to the main frame.
- (2) Reconnect the jumper wires on terminal strips on the rear panel if they have been disconnected for certain types of operation (TM 11-5820-357-20).
- (3) Check the primary source of power for the proper voltage.

*Note:* A tuning shaft that is out of synchronization or a trimmer adjustment that is misaligned may cause reduced output or no output. Check the synchronization of the shafts (para 73), and the position of the rf and crystal-oscillator band switches before adjusting individual tuning circuits (para 74 through 80).

*c. Troubleshooting Chart.*

Symptom	Probable trouble	Correction
When FUNCTION switch is in AGC position, receiver fails to operate and dial lamp does not light..	Open AC 3A fuse (F101) (on rear panel of receiver.	Replace fuse F101. If it blows again, check power supply (para 46) filament, and oven circuits for shorts.

Symptom	Probable trouble	Correction
2. Dial lamp lights, but CARRIER LEVEL meter does not deflect. No reception.	No B+ voltage. Open H.V. 3/8A fuse (F102) on receiver rear panel.	If fuse F102 blows again after replacement, check capacitor C101 (fig.17) for short. Check plate and screen grid circuits for shorts (para 53).
3. No receiver output. CARRIER LEVEL meter raises and dips as KILOCYCLE CHANGE control is rotated.	Fault is in signal circuit after 5th if. stage.	Test tubes in audio stages. Connect headset in series with a 0.1-uf capacitor across grid circuit and plate circuits of successive audio stages to localize defective stage. Defective stage may also be localized by signal substitution (para 50). Check voltage and resistance in defective stage (fig. 73). <i>Note: If the filament of a particular tube fails to light, trouble may be in another tube in the same series circuit. (Refer to TM 115820-357-20).</i>
4. Af circuits function satisfactorily but no signal output is obtained when 455-kc modulated signal is applied to if. Input (J525 or J526, fig. 25).	Faulty if. Stage .....	Test all tubes. Test if. stages, and crystal oscillators by signal substitution (para 50). Isolate fault by voltage and resistance measurements (fig. 39,72,73).
5. If. Circuits respond to 455-kc signal applied to antenna input but no station is heard.	Faulty mixer, oscillator, or rf stage. Crystal oscillator band switch or vfo tuning shaft out of synchronization.	Test mixer stages, rf stages, and crystal oscillators by signal substitution (para 50). Check synchronization of band switch and tuning shaft (para 73).
6. No beat frequency heard when BFO switch is turned ON and BFO PITCH control is varied.	Faulty bfo .....	Test V508. Check voltages at tube socket pins (fig. 39). Check BFO switch.
7. No calibration signal when FUNCTION switch is at CAL.	Defective calibration oscillator	Test V901 and V902. Substitute crystal Y901 for one that is known to be good. Check voltages and resistances of oscillator circuit (fig.72).
8. Excessive hum from ac power supply.	Defective filter capacitor or electronic voltage regulator.	Check for defective capacitor in power supply or voltage regulator circuit. Test tubes V605, v606, and V607. Check voltage across reference tubes V608 and V609 (fig.72).
9. Weak signal.....	Low voltage. Weak tubes.....	Check power-input voltage. Check B+ 180V DC at J601 (fig.32). Test tubes. Check gain of each stage (para 52) to localize trouble. Check for shorted capacitors. If no fault is indicated by a check of tubes and voltages when the output is weak, align tuning circuits (para 74-80).
10. Noisy receive .....	Noisy antenna location.....  Poor connections or shorted elements within a tube.  Loose connection at a terminal or within a part.	Short circuit antenna to ground by setting FUNCTION switch to CAL. (Receiver must not be tuned to an even 100-kc frequency, or the calibration signal will interfere with test). A considerable decrease in noise indicates noisy signal from antenna. Use insulated prod to tap each tube. If tapping a tube causes an increase in noise in the output, try a different tube. Tap the parts. Move terminals slightly, and listen for noisy output. Noise indicates that a connection should be soldered or that a part needs replacing.
11. Receiver output noisy when controls are operated.	Dirty switch contacts. Poor contact at rotor of a gain control.	Clean switch contacts. Clean and lubricate control(TM 11-5820-357-20), or replace.

Symptom	Probable trouble	Correction
12. Distorted signal.....	Weak tube. Incorrect voltage on tube. Defective C603 or C610.	Check tubes and replace if necessary. Check voltages and resistance in af subchassis (fig 72). Use headset connected in series with a 0.1 -uf capacitor to check signal across grid and plate circuits of audio stages to localize troubles.
13. Receive inoperative on one band.	Faculty band switch.....	Check band switch as outlined in paragraph 73b.
14. Receiver inoperative on several bands.	Faulty crystal.....	Check crystal as outlined in paragraph 51.
15. Receiver noisy with FUNCTION switch set to SQUELCH.	Faulty V601B.....	Check tube and replace if necessary

## 50. Signal Substitution

*a. General.* Signal substitution in Radio Receiver R-390/URR requires RF Signal Generator AN/URM-25(\*) for checking the af, rf, variable if., and fixed if stages of the receiver. After locating a defective stage, check the tube; then use the schematic diagram (fig. 74) and the voltage and resistance diagrams (fig. 39, 71, and 72) to help locate the defective component.

- (1) Use Test Set, Electron Tube TV7(\*)/U to check suspected tubes.
- (2) Use Electron Multimeter TS-505(\*)/U to take voltage and resistance measurements. Most circuit components can be checked by measurements taken from the tube socket.  
*Note:* To inject a signal where no test jack is provided, and to take voltage and resistance measurements without removing a subchassis, insert a tube socket adapter in the tube socket of the stage under test and replace the tube in the adapter.

*b. Signal Substitution Procedures.* For the tests described in *c*, *d*, and *e* below, connect the ground lead of AN/URM-25(\*) to the subchassis being tested and connect the output lead through a 0.05-microfarad (uf) capacitor to the test connection point. Connect a headset to the PHONES jack unless otherwise specified.

- (1) Note the volume, and listen for distortion from the speaker or headset at various points in the signal substitution procedure. Be sure that the LIMITER control is in the OFF position; if it is in the ON position, it may be the cause of the distortion.
  - (2) When working back from the output to the input stages, decrease the output of the AN/URM-25(\*) as much as possible. If possible, compare results with a receiver known to be in good condition.
  - (3) Trouble in a circuit or stage does not always change the resistance measurements at the tube socket or terminal board. These instructions merely serve as a guide, and suggest other procedures, such as voltage and resistance measurements across individual parts.
  - (4) In each step, assume that all previous steps were completed satisfactorily. Isolate and clear any trouble discovered before proceeding with succeeding steps.
  - (5) Refer to the note in paragraph 42d while performing the tests.
- c. Audio Tests* (fig. 32 and 72).

Step	Test connection	Normal indication	Corrective measures
1	Apply a 40 - cycle audio signal to pin 5 of V603. Connect headset to PHONES jack	Very weak signal in headset.....	Check headset. Check the seating of J619 on af chassis. Check T602 Check C604 for short.
2	Apply a 400-cycle audio signal to pin 1 of V603	Increase in audio volume.....	Check voltages and resistances of V603 circuit components

Step	Test connection	Normal indication	Corrective measures
3	Apply a 400-cycle audio signal to pin 1 of V602	Audio volume the same as noted in step 2.	Check C603.
4	Turn the LOCAL GAIN control fully clockwise. Apply a 400-cycle audio signal to pin 2 of V602.	Audio volume much louder than noted in step 3	Check voltages and resistances of V602 circuit components.
5	Connect headset across terminals 10 and 13 of rear terminal strip TB101 (refer to TM 11-5820-357-20). Apply a 400-cycle audio signal to pin 5 of V604.	Very weak signal in headset---	Check to see that jumper is connected between terminals 11 and 12 of TB101. (Refer to TM) Check T603 by resistance measurements.
6	Apply a 400-cycle audio signal to pin 1 of V604.	Audio volume much louder than noted in step 5	Check C611 for short. Check V604 circuit components by resistance measurements. If audio is distorted check C610 for leakage.
7	Apply a 400-cycle audio signal to pin 6 of V6 02. Turn the LINE GAIN control fully clockwise	Audio volume same as noted in step 6.	Check C610 for an open.
8	Set the AUDIO RESPONSE switch to MED. Apply a 400-cycle audio signal to pin 6 of V6 02.	Audio volume somewhat less than noted in step 7.	Check C602 for short. Check T601 by resistance measurements.
9	Apply a 400-cycle audio signal to pin 7 of V601.	Audio volume greater than noted in step 8.	Check connections to AUDIO RESPONSE switch. Check V601 circuit components by resistance measurements.

d. If. Subchassis Test (fig. 25-27, and 39).

Step	Test connection	Normal indication	Corrective measures
1	Apply a 400-cycle audio signal to pin 2 of V150. Connect the headset to the phone jack.	A loud audio signal should be heard in the headset.	Check C529. Check the seating of P117 in the if. chassis. Check the seating of P119 in the local af chassis.
2	Apply a 400 cycle audio signal to pin 3 of V510.	The audio signal should be about as loud as noted in step 1.	Check R542 and R544.
3	Apply a 400-cycle audio signal to pin 7 of V507.	Audio volume the same as noted in step 2.	Check C551 for short. Check. R541.
4	Apply a modulated 455-kc signal to pin 1 of V507	Audio signal in headset	Check for jumper between terminals 14 and 15 of TB101. (Refer to TM 11-5820-357-20.)
5	Apply a modulated 455-kc signal to pin 5 of V506.	Audio volume same as noted in step 4.	Check circuit components of V507 by voltage and resistance measurements.
6	Apply a modulated 455-kc signal to pin 1 of V506	Audio volume slightly louder than noted in step 5.	Take voltage and resistance measurements on V526 circuit (fig 39). Check V506 circuit components.
7	Make the following settings on the receiver: FUNCTION switch to MGC. RF GAINCONTROL FULLY clockwise. Apply a modulated 455-kc signal to pin 5 and then to PIN 1 OF V505, V504, V503, V502, and V501, in that order.	Audio volume increases when the applied signal is moved from pin 1 of a tube to pin 5 of the preceding tube.	Take voltage and resistance measurements of any stage that does not give normal indications. Check the components of any stage that does not provide a normal indication

e. Rf Subchassis Tests (fig. 20-24, 28, 29, and 39).

Step	Test connection	Normal indication	Corrective measures
1	Apply a modulated 455-kc signal to pin 1 of V205 (fig 38).	Audio signal in headset.....	Check seating of P226 in the if. chassis. Check seating of P225 in the if. chassis Check T207 by resistances measurements.
2	With the FUNCTION switch at STAND BY, apply a modulated 2-mc signal to E210 (fig 20).	Audio signal in headset.....	Check V205. Check V701. Check V701 circuit components by voltage and resistances measurements. Check vfo operation by measuring de voltage at E210 with TS-505/U. The voltage should be between -3 and -11 volts de. If the voltage is out of these limits, check J223 and P723. Check coupling of vfo shaft (para 73). Check V205 circuit components.
3	Set FUNCTION switch to MGC. Apply a modulated 2-mc signal to pin 1 of V204.	Audio heard in headset.....	Check synchronization of Z222, Z223, and Z224(para 73) if signal is weak.
4	Apply a modulated 10mc signal to E209 (fig 20) <i>Note:</i> For remainder of rf subchassis tests, tune receiver to 2 mc by setting the frequency controls for a frequency indicator reading of 01+000.	Audio heard in headset.....	Check 2d crystal oscillator output by measuring the dc voltage at E209 with a TS-505/U (FUNCTION switch at STAND BY). Normal voltage is 3 to 11 volts dc. Check V402 circuit components if voltage is abnormal.
5	Set FUNCTION switch to MGC Apply a modulated 10mc signal to pin 1 of V203 (fig 20).	Audio heard in headset.....	Check V204 circuit components. Check synchronization of first if cam rack and alignment of Z219, Z220, and Z221 (fig 20) if output is weak (par 47 and 73 ) Check V203 plate circuit components.
6	Apply a modulated 2-mc signal to E208 (fig 20).	Audio heard in headset.....	Check 1st crystal oscillator by measuring the dc voltage at E208 with a TS-505/U (FUNCTION switch at STAND BY). The normal voltage is -3 to -11 volts. Check V401 circuit components if voltage is abnormal. Check alignment of 1st crystal oscillator (para 73). Check synchronization of 1st crystal oscillator (para 78). Check V401 circuit components.
7	Set function switch to MGC Apply a modulated 2-mc signal to pin 5 of V202.	Audio heard in headset.....	Check coupling circuits between V202 and V203.
8	Apply a modulated 2-mc signal to E207 (fig 20).	Audio much louder than noted in step 7.	Check V202 circuit components . Check V202.
9	Apply a modulated 2-mc signal to pin 5 of V201 (fig 20).-	Audio volume about the same as noted in step 8.	Check V201 plate circuit and coupling components.
10	Apply a modulated 2-mc signal to E206 (fig 20).	Audio volume louder than noted on step 9.	Check V201 circuit components.

Step	Test connection	Normal indication	Corrective measures
11	Apply a modulated 2-me signal in turn, to UNBALANCED WHIP antenna input and BALANCED 125 OHM antenna input.	Loud audio volume.....	Check antenna tuning circuits. Check S201. Check K101.

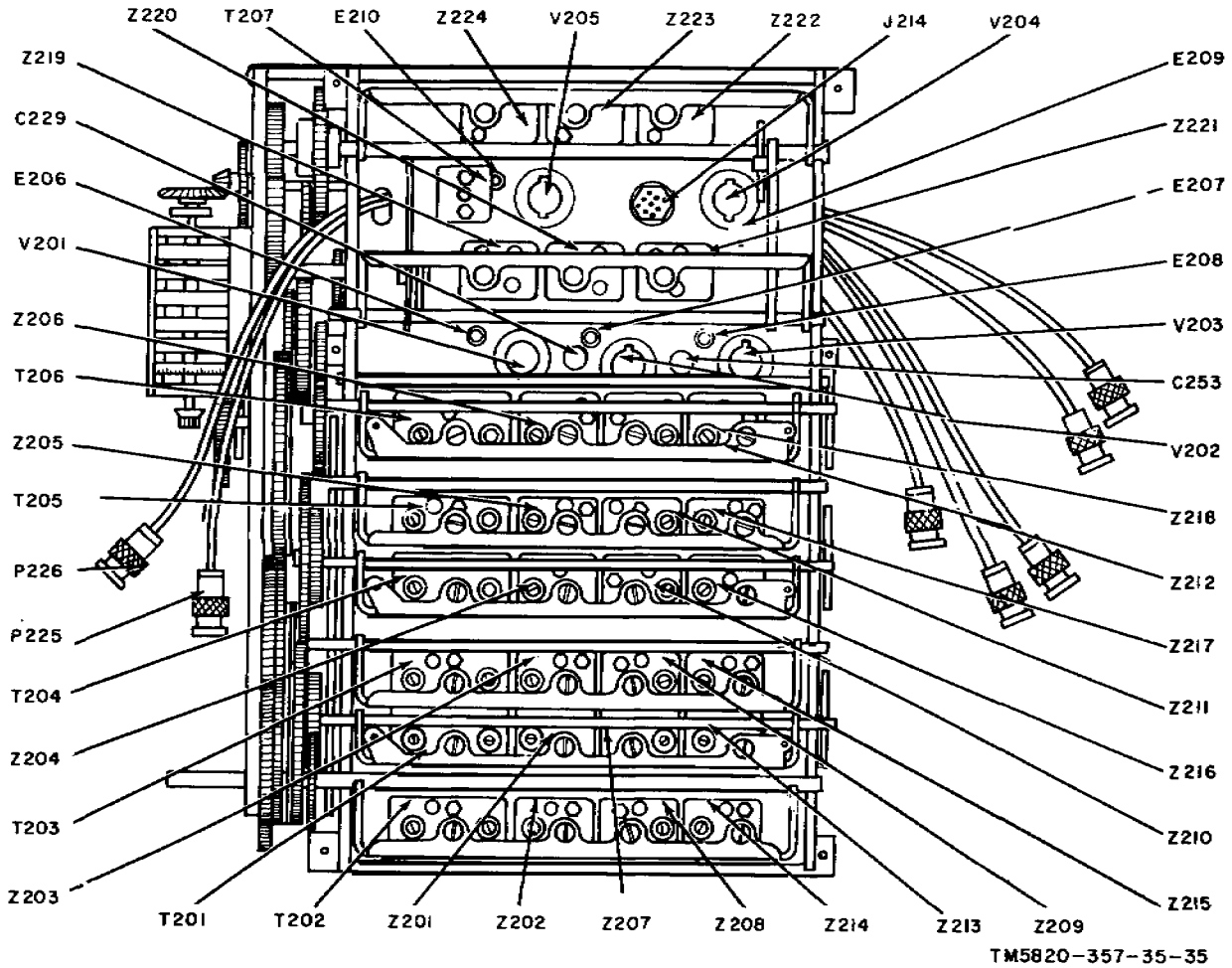

Figure 20. Rf subchassis, top view.

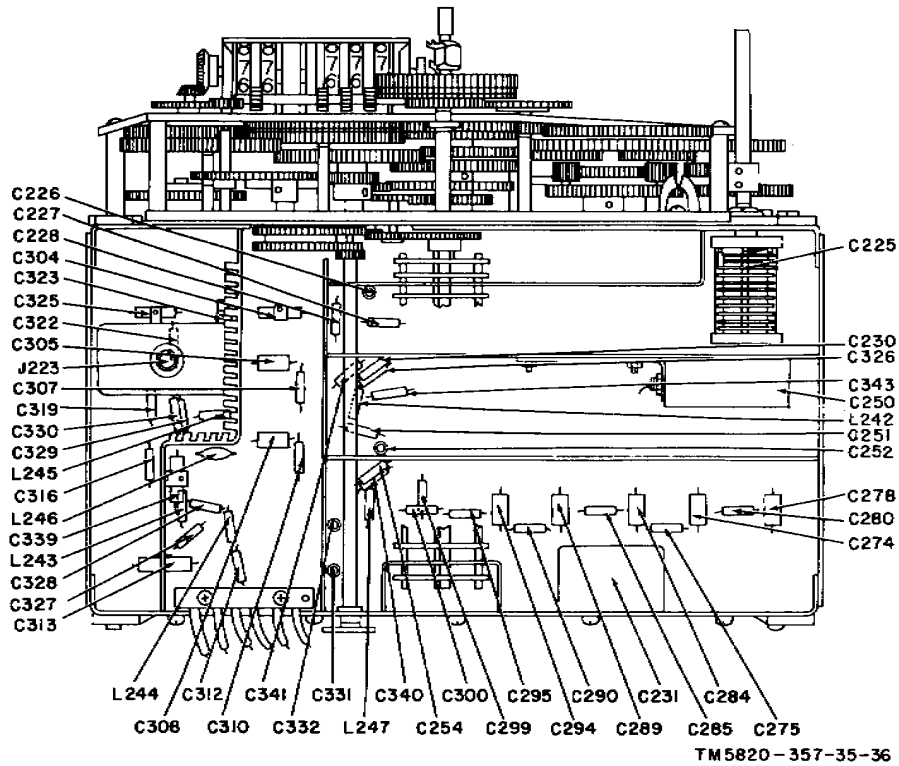

Figure 21. Rf Subchassis, coil and capacitor location.

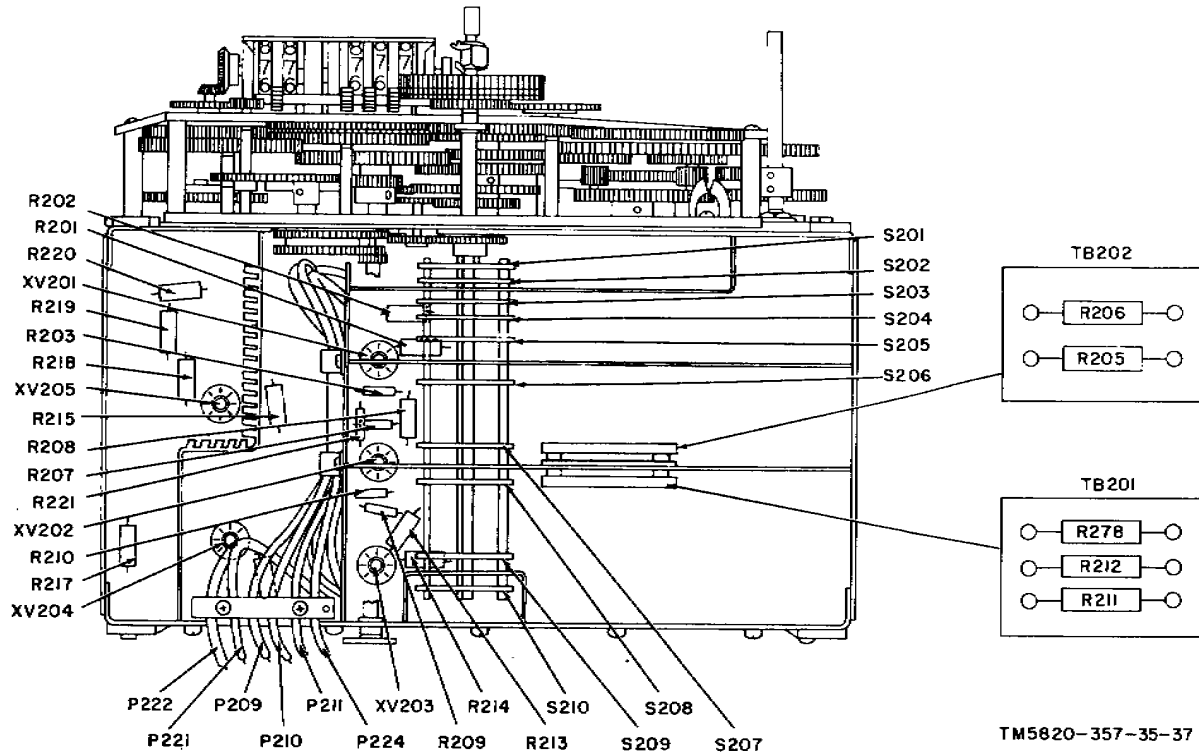

Figure 22. Rf subchassis, bottom view.

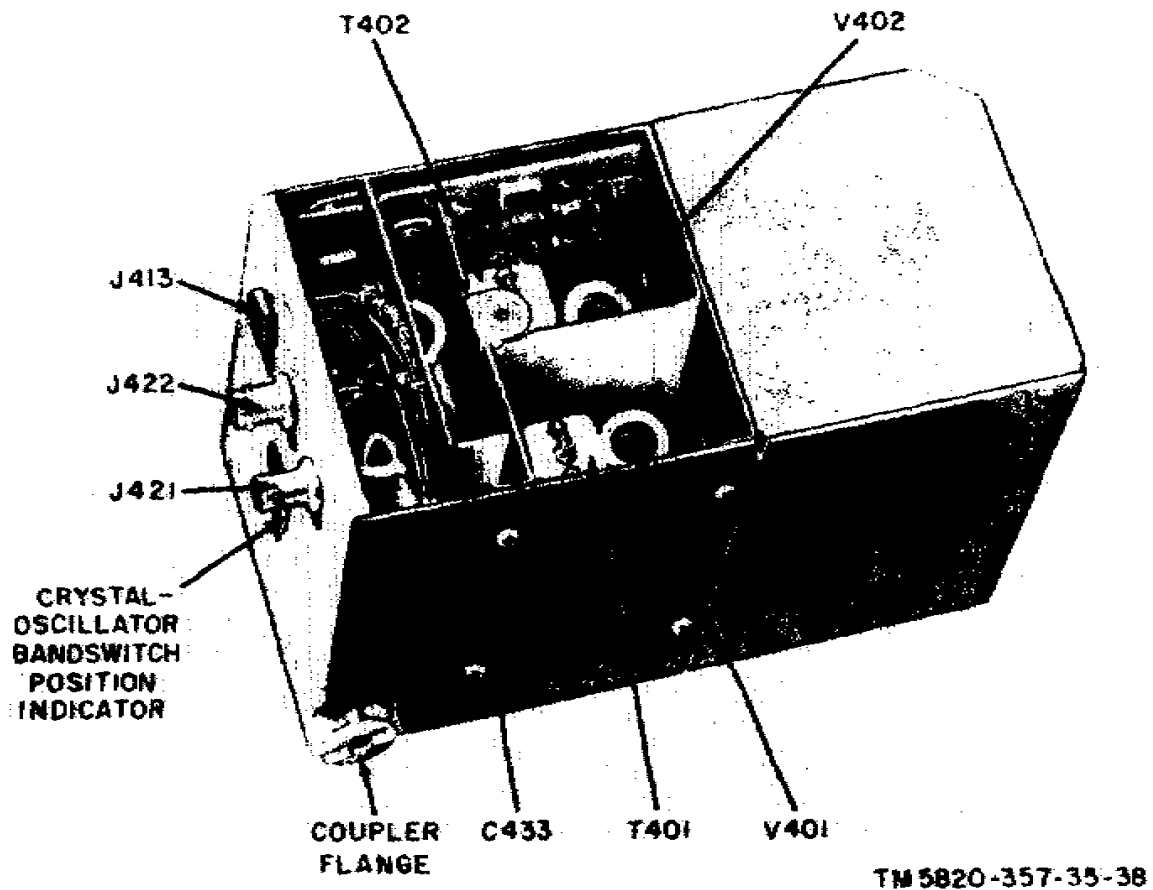

Figure 23. Crystal-oscillator subchassis, top view.

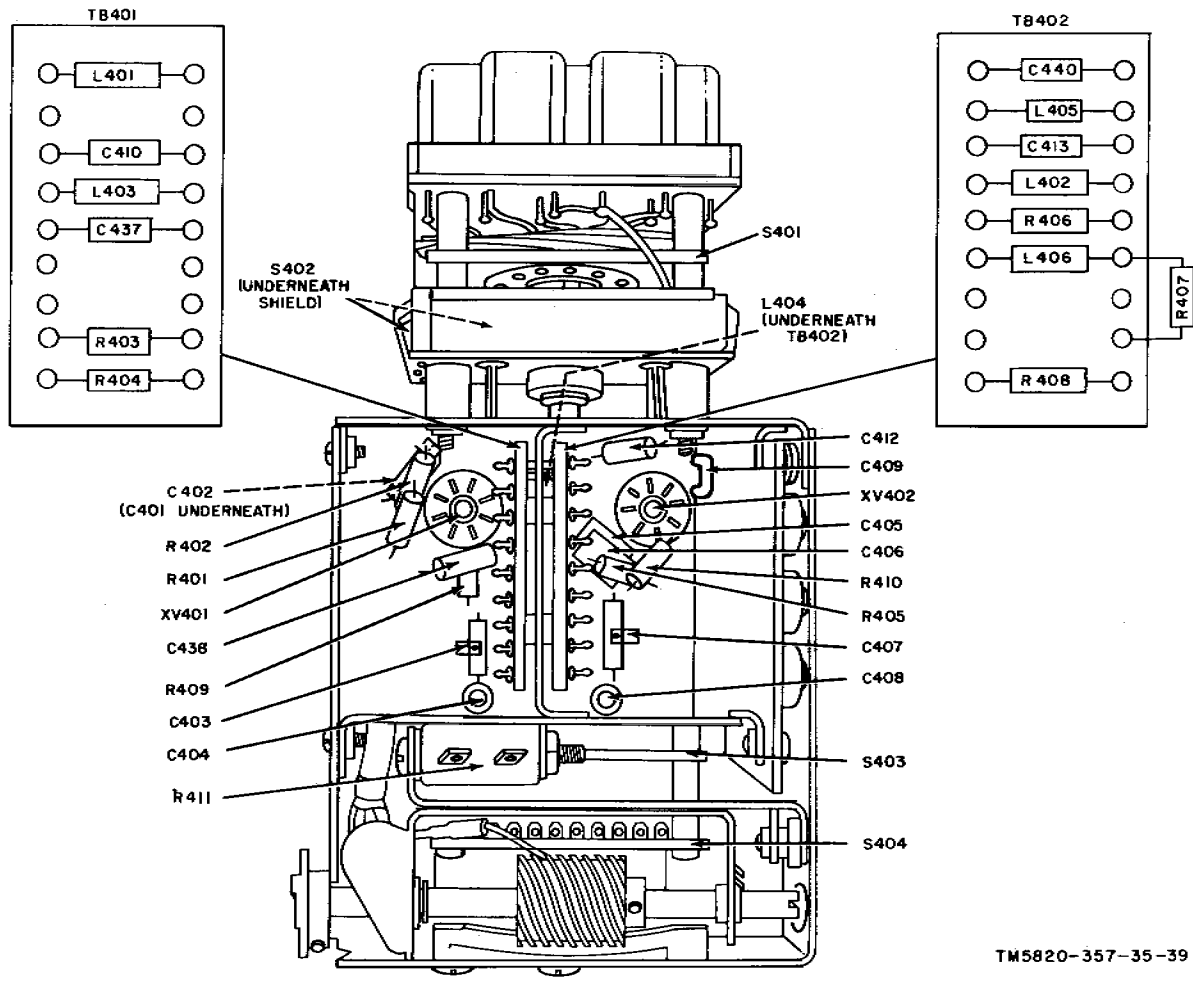
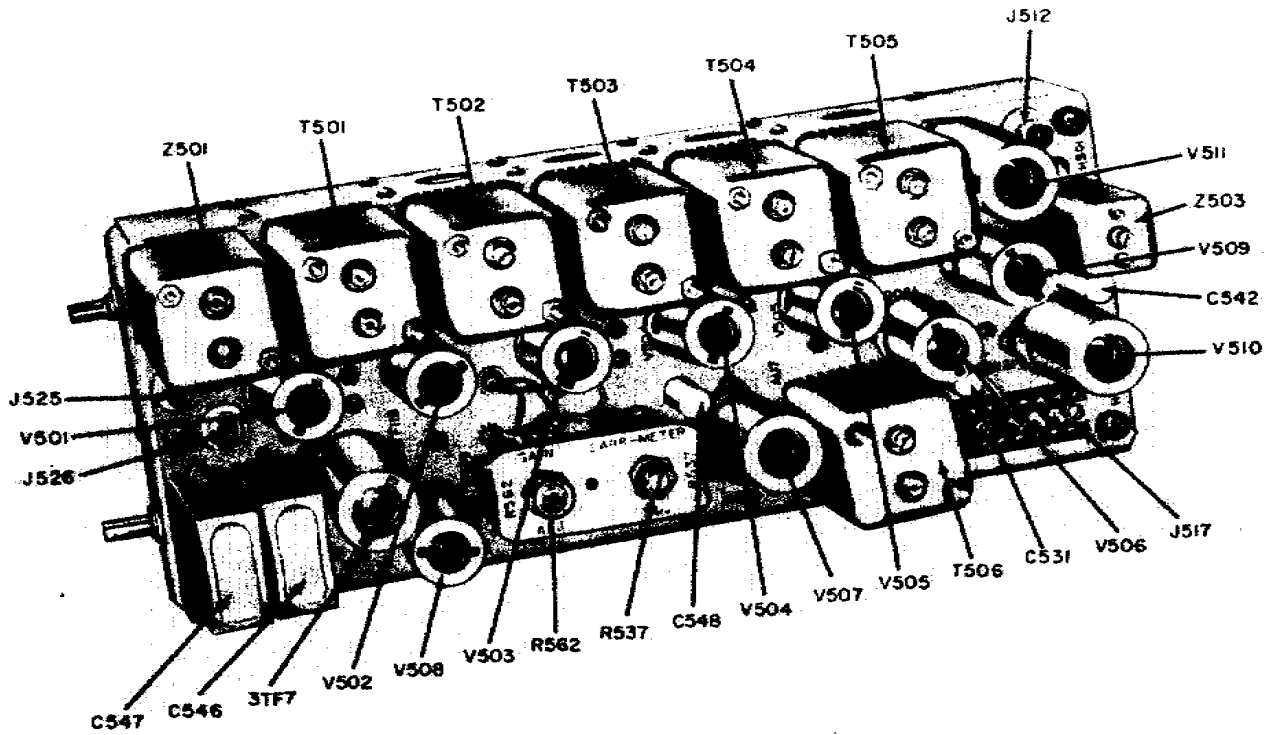
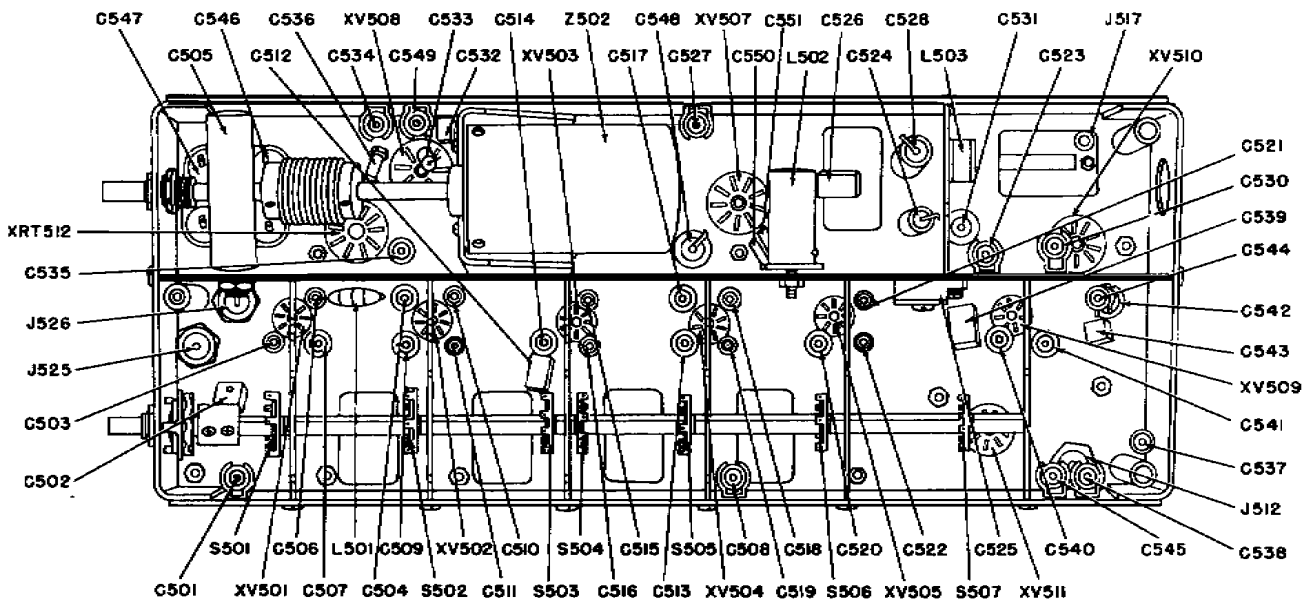

Figure 24. Crystal-oscillator subchassis, bottom view.



TM5820-357-35-41

Figure 25. *lf. subchassis, top view.*



TM5820-357-35-42

Figure 26. *lf. subchassis, bottom view.*

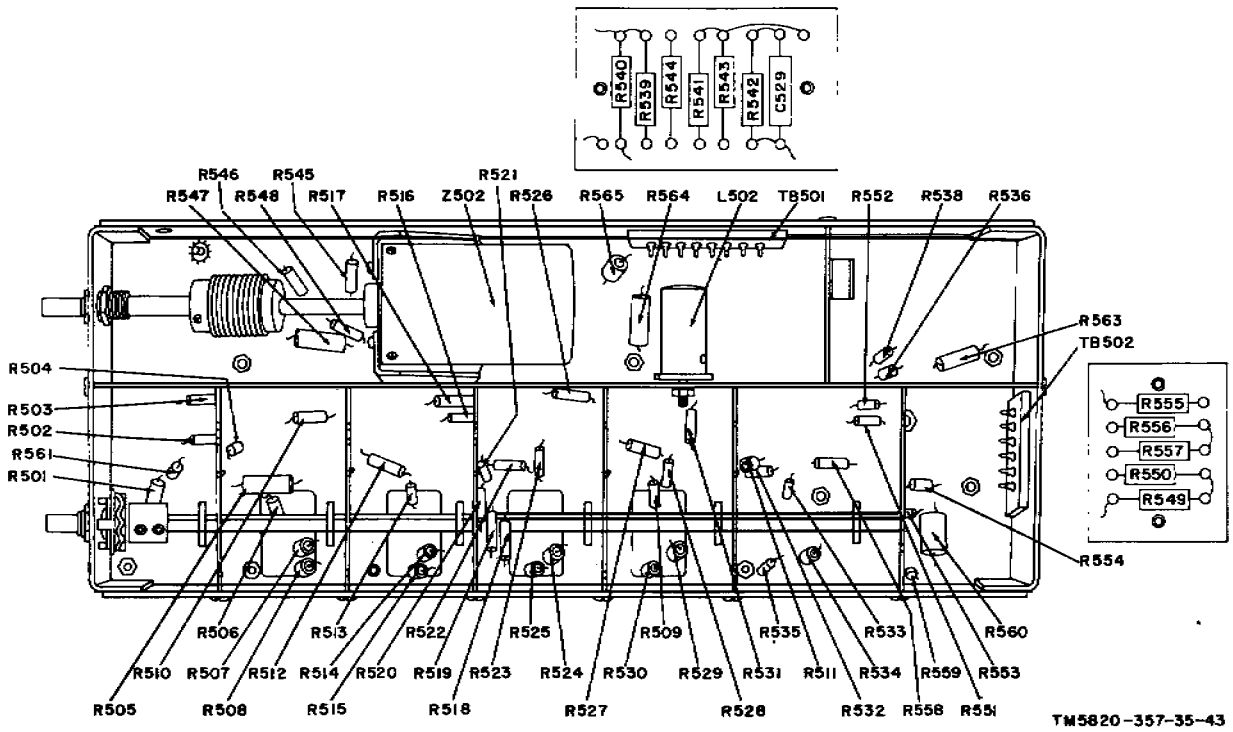

Figure 27. If. subchassis, location of resistors.

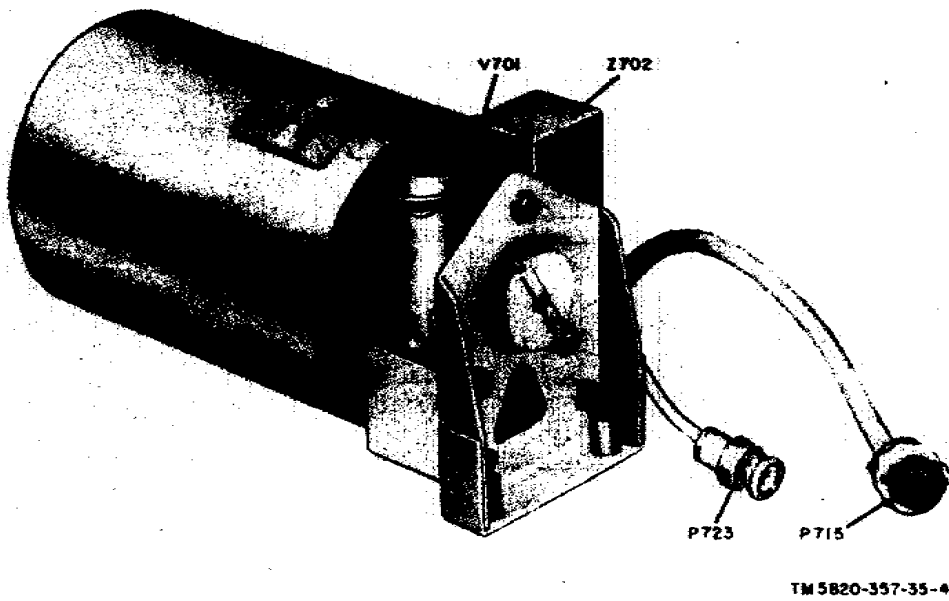

Figure 28. Vfo subchassis, top view.

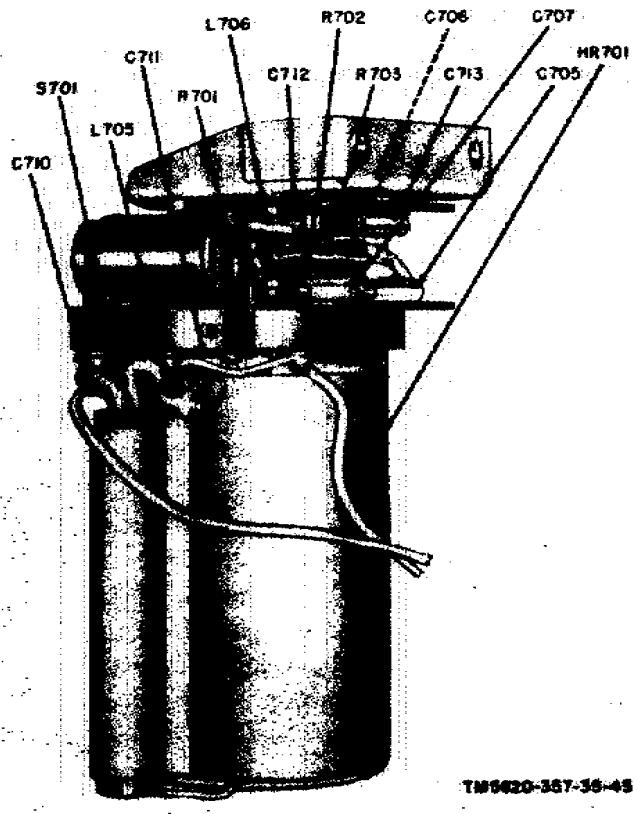

Figure 29. Vfo subchassis, bottom view.

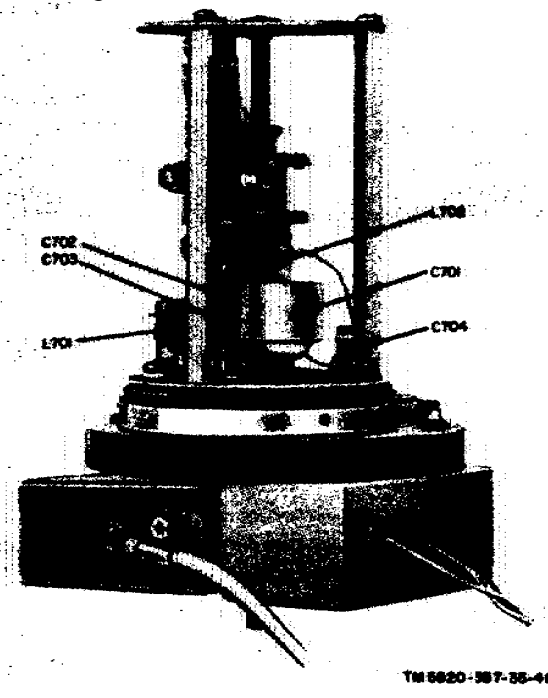
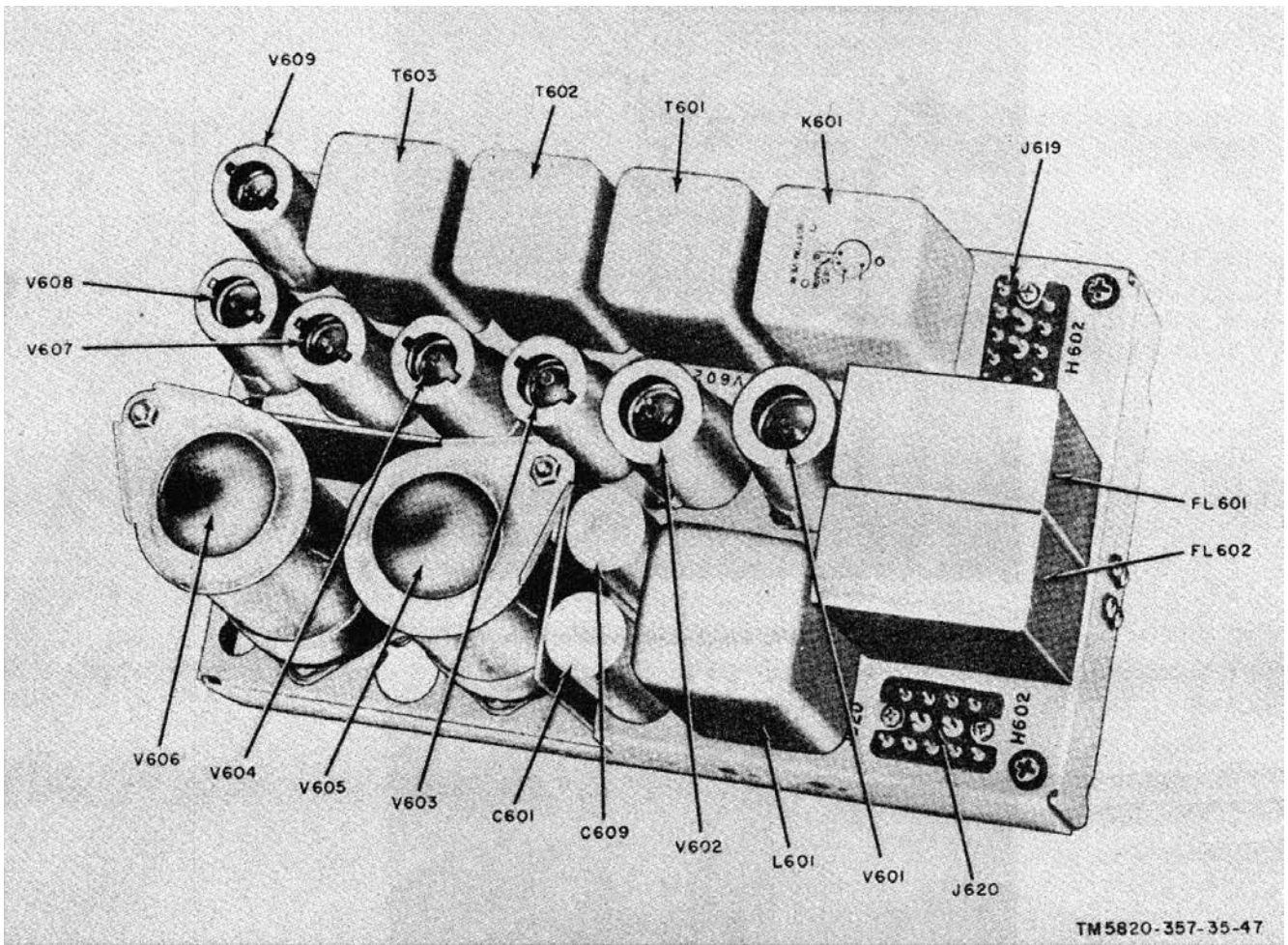

Figure 30. Vfo subchassis, cover removed.



TM5820-357-35-47

Figure 31. Af subchassis, top view.

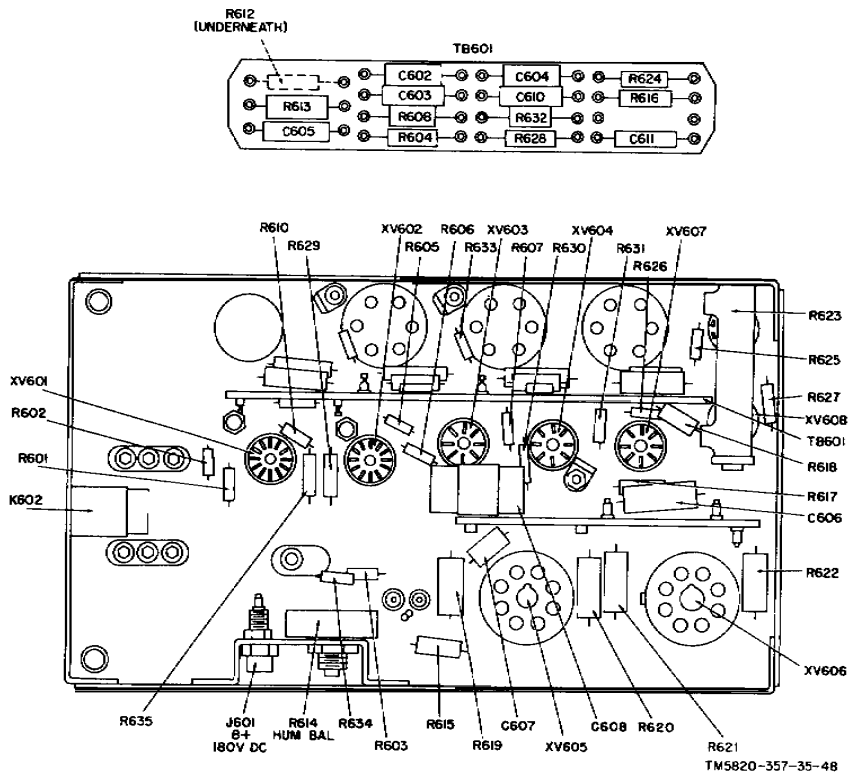

Figure 32. Af subchassis, bottom view.

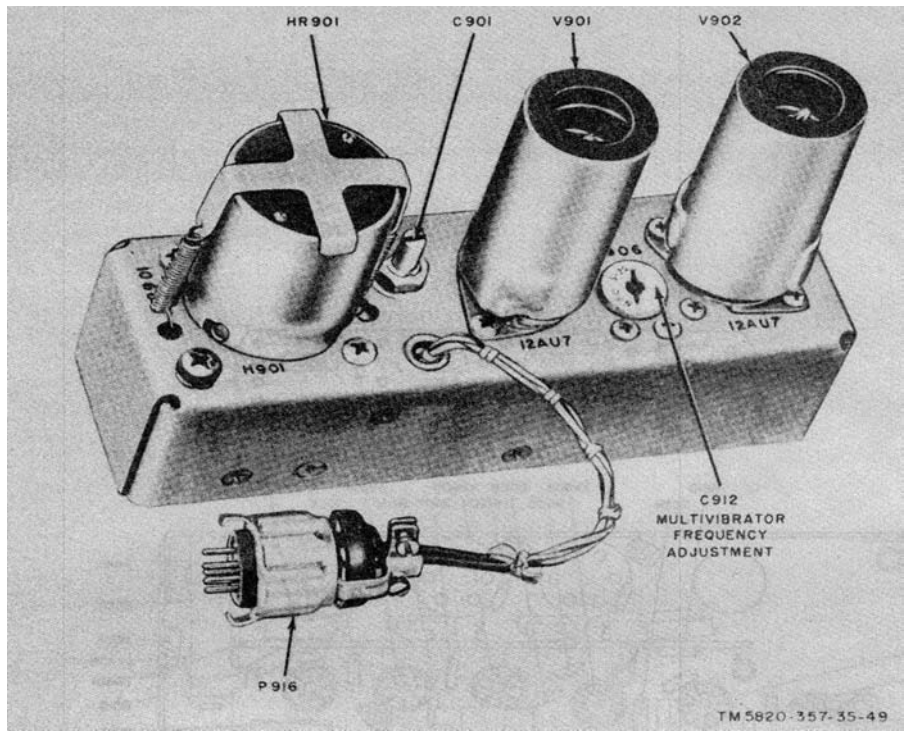

Figure 33. Calibration-oscillator, top view.

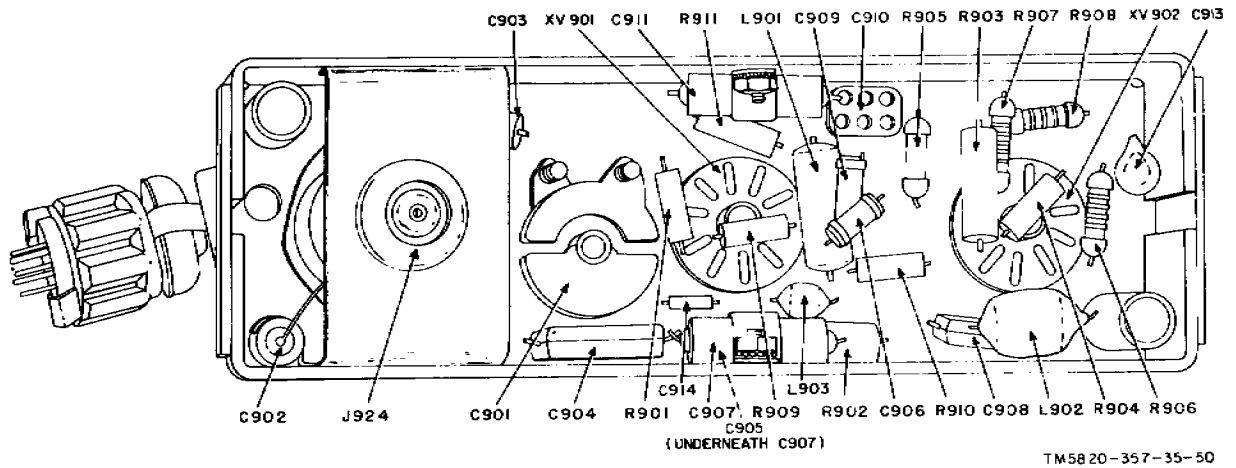

Figure 34. Calibration-oscillator, bottom view.

## 51. Checking Oscillator Crystals

If an oscillator crystal is suspected, it can be checked by substitution of a crystal of the same type known to be good.

### *a. First Crystal-Oscillator Crystal Location.*

The following chart lists the crystal symbol, the crystal fundamental frequency, and the bands in which each crystal in the first crystal oscillator is used. Refer to TM 11-5820-357-20 for crystal location.

Crystal symbol	Crystal fundamental frequency (mc)	Bands (mc)
Y401	9	0.5-1 6-7
Y402	8	1-2 5-6
Y403	10	2-3 7-8
Y404	12.6	3-4
Y405	7	4-5

### *b. Second Crystal-Oscillator Crystal Location.*

The following chart lists the crystal symbol, the crystal fundamental frequency, and the bands in which each crystal in the second crystal oscillator is used. Refer to TM 11-5820-357-20 for crystal location.

Crystal symbol	Crystal fundamental frequency (mc)	Bands (mc)
Y406	12	0.5-1 1-2 9-10 21-22
Y407	15	2-3 12-13
Y408	6.2	3-4
Y409	14	4-5 11-12 25-26
Y410	8	5-6 13-14
Y411	9	6-7 15-16 24-25
Y412	10	7-8 17-18 27-28
Y413	11	8-9 19-20 30-31

Crystal symbol	Crystal fundamental frequency (mc)	Bands (mc)
Y414	13	10-11 23-24
Y415	8.5	14-15
Y416	11.333	31-32
Y417	10.666	29-30
Y418	10.333	28-29
Y419	9.667	26-27
Y420	12.5	22-23
Y421	11.5	20-21
Y422	10.5	18-19
Y423	9.5	16-17

## 52. Stage Gain Charts

The stage gain charts (*a* and *b* below) list the minimum and maximum voltages required at each of the rf and if. stages of the receiver to produce -7 volts across the diode-load resistor. Use these charts to check the overall gain of the receiver and the gain of each rf or if. stage or group of stages. When the receiver output is low, localize the defective stage by checking the signal voltage level of each stage against the chart while using the signal substitution method of troubleshooting, or by measuring the individual stage gain. To obtain stage-gain readings, connect a TS-505(\*)/U, between terminals 14 (DIODE LOAD) and 16 (GND) of file terminal strip behind the receiver. Terminal 14 must be jumpered to terminal 15. Connect Lead, Test CX-2919/U(part of AN/URM-25D or AN/ URM-25F) between receiver chassis ground and the test points indicated in the charts below. When the 455-kc if stages are checked, access to the injection points can be gained by operation of the subchassis outside the receiver, using the extension cables (para 47), or by insertion of tube-socket adapter as explained in paragraph 49a. Check the output from the signal generator required to obtain the diode-load reference voltage of -7 volts tic against the values given in the charts. The lowest value is the minimum and the highest is the maximum that should be required over the specified frequency range for normal operation. A reading that is slightly outside this range does not necessarily indicate improper functioning.

a. Rf Subchassis Stages.

Signal generator output connection	BAL-ANCED 125 OHM		Test point E206 (1 <sup>st</sup> rf grid V201)	Test Point E207 (2 <sup>nd</sup> rf grid V202)	Test point E208 (1 <sup>st</sup> mixer grid V203)		Test point E209 2d mixer grid V204)			Test point E210 3d mixer grid V205)	
	0.5-32 1-4	0.5-32 4-16	0.5-32 28-78	0.5-8 40-62	9-18 36-53	9-18 43-59	3-2 23-28	8-32 41-71	3-2 92-117	0.455 22-50	
Frequency (mc)											
Signal generator output (microvolts).											

b. If. Subchassis Stages.

Signal generator output connection	Signal generator output (Microvolts)			
	2-kc bandwidth	4-kc bandwidth	8-kc bandwidth	16-kc bandwidth
1st if. grid V501 .....	130 to 180			
2d if. grid V502 .....	1,500 to 1,900	1,400 to 2,000	880 to 1,400	860 to 1,700
3d if. grid V503 .....	2,300 to 5,000	3,000 to 5,000	1,100 to 2,000	770 to 1,300
4th if. grid V504 .....	7,000 to 12,000	7,000 to 11,500	6,000 to 8,700	5,200 to 7,600
5th if. grid V505 .....	16,000 to 20,000	16,000 to 18,000	23,000 to 28,000	32,000 to 38,000
6th if. grid V506 .....	420,000 to 500,000	420,000 to 500,000	420,000 to 500,000	420,000 to 500,000

53. Isolating Trouble Within Stage

When the trouble has been localized to a stage, use the following techniques to isolate the defective part:

a. Test the tube or tubes in the suspected stage; use Test Set, Electron Tube TV-7(\*)/U. or equivalent, or substitute a similar type tube known to be good.

b. Take voltage measurements at the tube sockets (fig. 39 and 71).

c. Take voltage measurements at other points related to the suspected stage.

d. If voltage readings are abnormal, take resistance measurements (fig. 39 and 71) to isolate open and short circuits. Refer to paragraph 54 for the dc resistances of transformers and coils.

e. If signals are weak and all of the previous checks fail to indicate a defective part, check the alignment of all stages.

54. Dc Resistances of Transformers and Coils

The dc resistances of the transformer windings and the coils in the receiver are listed below:

Transformer or coil	Terminals	Ohms
Z201 .....	.....	2.4
Z202 .....	.....	1.9
Z203 .....	.....	1.1
Z204 .....	.....	Less than 1

Transformer or coil	Terminals	Ohms
Z205 .....	.....	Less than 1
Z206 .....	.....	Less than 1
Z207 .....	.....	2.4
Z208 .....	.....	1.8
Z209 .....	.....	1
Z210 .....	.....	Less than 1
Z211 .....	1-3 .....	Less than 1
Z212 .....	.....	Less than 1
Z213 .....	.....	2.5
Z214 .....	.....	1.8
Z215 .....	.....	1.1
Z216 .....	.....	Less than 1
Z217 .....	.....	Less than 1
Z218 .....	.....	Less than 1
Z219 .....	.....	Less than 1
Z220 .....	.....	Less than 1
Z221 .....	.....	Less than 1
Z222 .....	.....	1.6
Z223 .....	.....	1.6
Z224 .....	.....	1.6
L401 .....	.....	7
L402 .....	.....	7
L403 .....	.....	1
L404 .....	.....	1
L405 .....	.....	1
L406 .....	.....	7
T401 .....	1-2 .....	Less than 1
	3-4 .....	Less than 1
T402 .....	1-2 .....	Less than 1
	3-4 .....	Less than 1
L501 .....	.....	7
L502 .....	.....	4.5
L503 .....	.....	7
T501 .....	2-9 .....	Less than 1
	3-7 .....	3.1

Transformer or coil	Terminals	Ohms	Transformer or coil	Terminals	Ohms	
T502, T503, T504, and T505	3-10.....	Less than 1	T602 <sup>a</sup> and T603 <sup>a</sup> .....	5-6.....	26	
	4-10.....	Less than 1		1-2.....	850	
	5-10.....	Less than 1		3-4.....	24	
	6-10.....	Less than 1		5-6.....	26	
	2-9.....	Less than 1		L901.....	.....	Less than 1
	3-7.....	3.1		L902.....	7.....	.....
	3-10.....	Less than 1		T801.....	1-2.....	Less than 1
	4-10.....	Less than 1		.....	3-4.....	Less than 1
	5-10.....	Less than 1		.....	5-6.....	25
	6-10.....	Less than 1		.....	6-7.....	25
T506.....	8-10.....	Less than 1	.....	5-7.....	50	
	1-2.....	Less than 1	.....	8-9.....	Less than 1	
	1-9.....	Less than 1	.....	9-10.....	Less than 1	
Z501.....	4-6.....	1.2	8-10.....	.....	Less than 1	
	1-2.....	5	FL101.....	A-A (J104).....	Less than 1	
Z503.....	.....	5.5	.....	D-D (J104).....	.....	
Z502.....	C532.....	1.7	K101.....	.....	17	
.....	through	.....	L242.....	.....	1	
.....	coil to pin	.....	L243.....	.....	1	
.....	7 of V508	.....	L246.....	.....	7	
.....	Pin 7 of	Less than 1	T201.....	1-2.....	Less than 1	
.....	V508	.....	.....	3-6.....	2.5	
.....	through	.....	T202.....	1-2.....	Less than 1	
.....	coil to grd.	.....	.....	3-6.....	1.8	
FL601.....	IN-OUT.....	50	T203.....	1-2.....	Less than 1	
.....	IN-gnd.....	24	.....	3-6.....	1.1	
.....	OUT-gnd.....	24	T204.....	1-2.....	Less than 1	
FL602.....	IN-OUT.....	37	.....	3-6.....	Less than 1	
.....	IN-gnd.....	230	T205.....	1-2.....	Less than 1	
.....	OUT-Gnd.....	250	.....	3-6.....	Less than 1	
K601.....	4-5.....	10K	T206.....	1-2.....	Less than 1	
K602.....	3-4.....	8	.....	3-6.....	Less than 1	
L601.....	.....	90	T207.....	1-5.....	2.8	
T601.....	1-2.....	850	.....	2-4.....	4.5	
.....	3-4.....	24	.....	.....	.....	

<sup>a</sup>Measurements taken with Speaker disconnected.

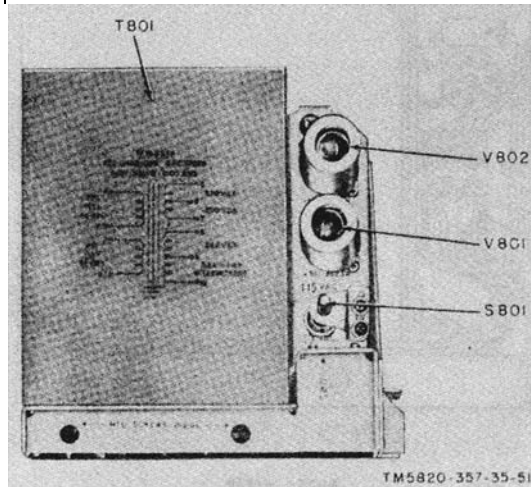

Figure 35. Power Supply PP-621/URR, top view.

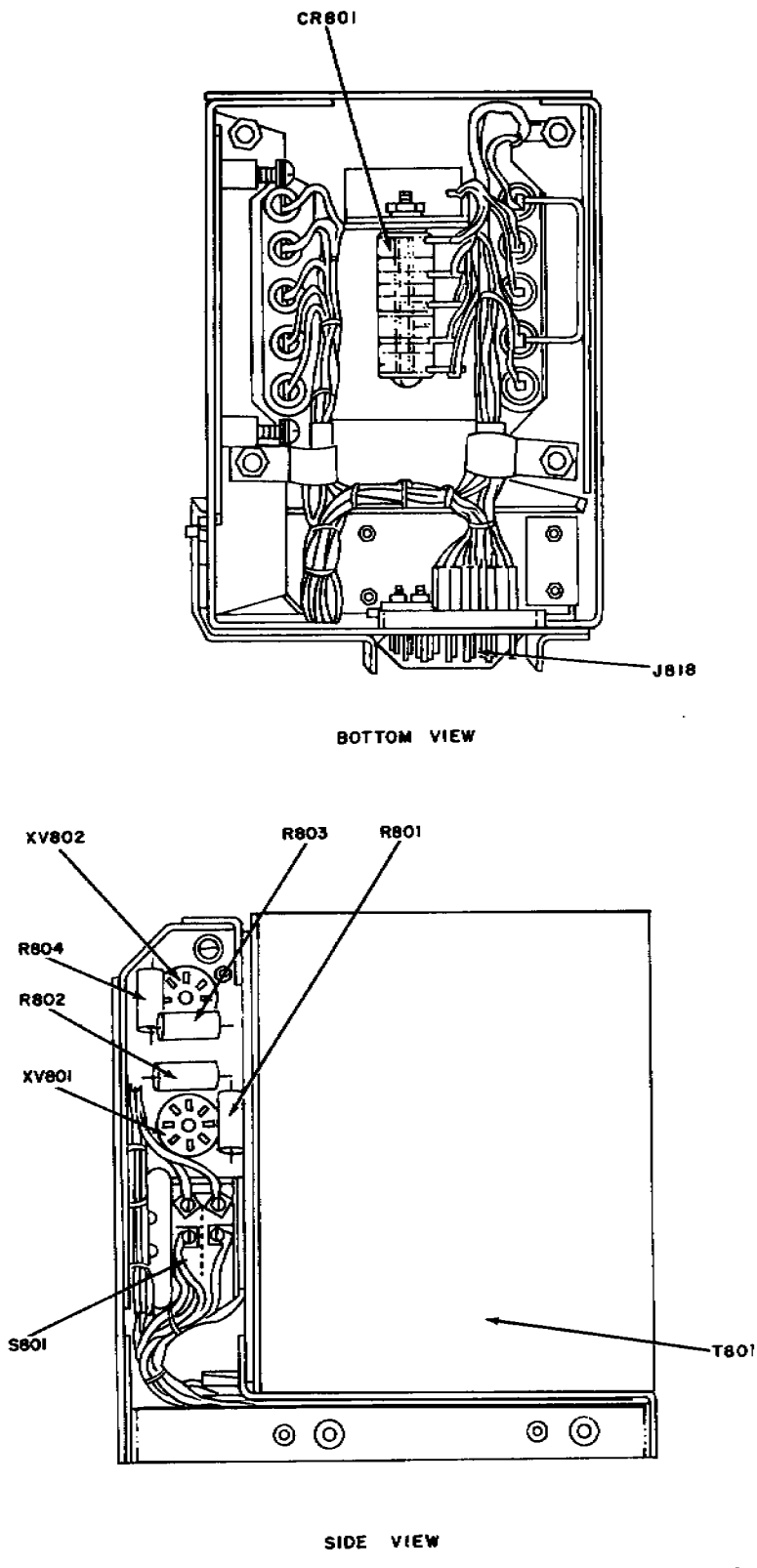
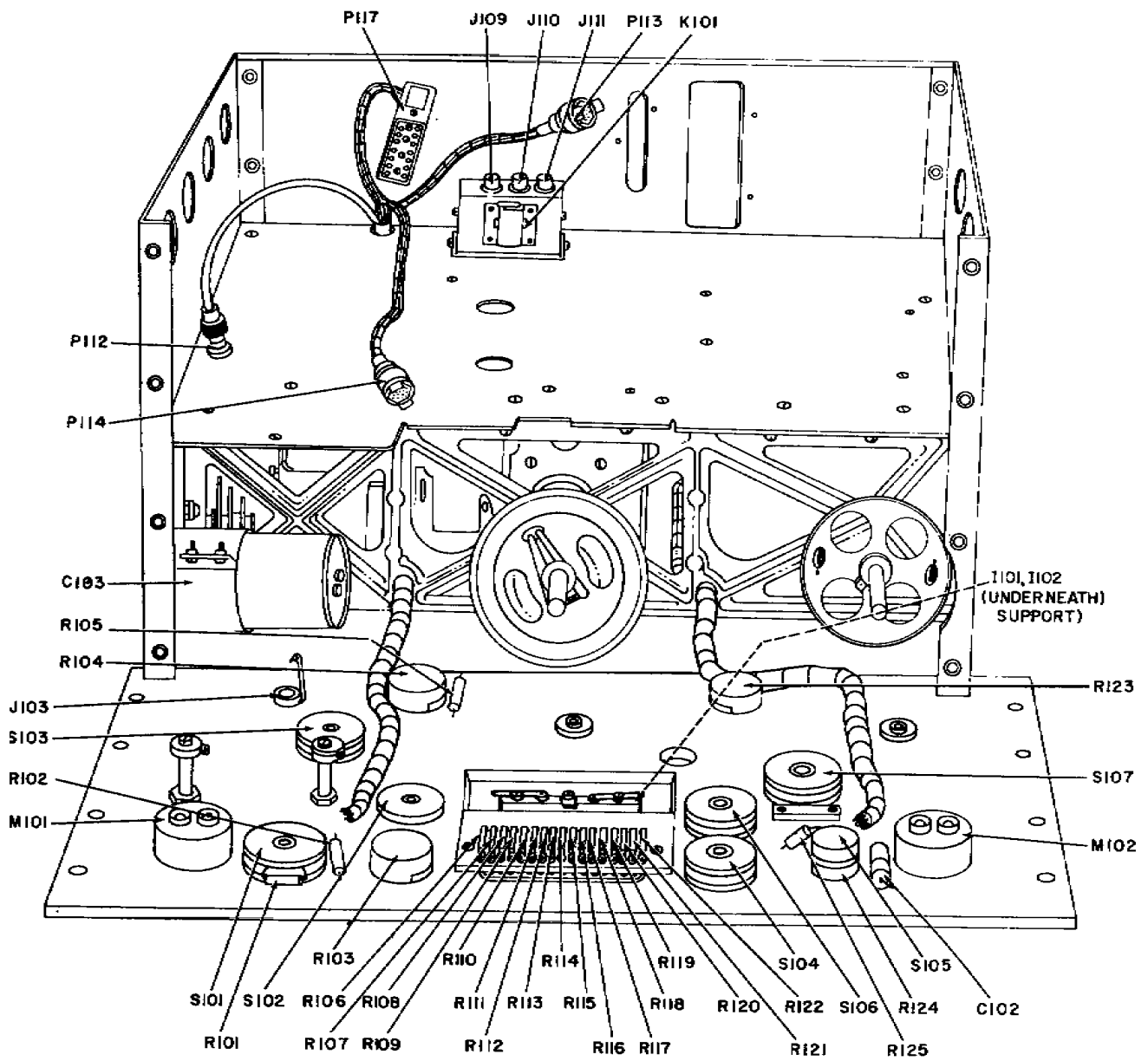

Figure 36. Power Supply PP-621/URR, bottom and side views.



TM5820-357-35-53

Figure 37. Front panel and main frame, top view.

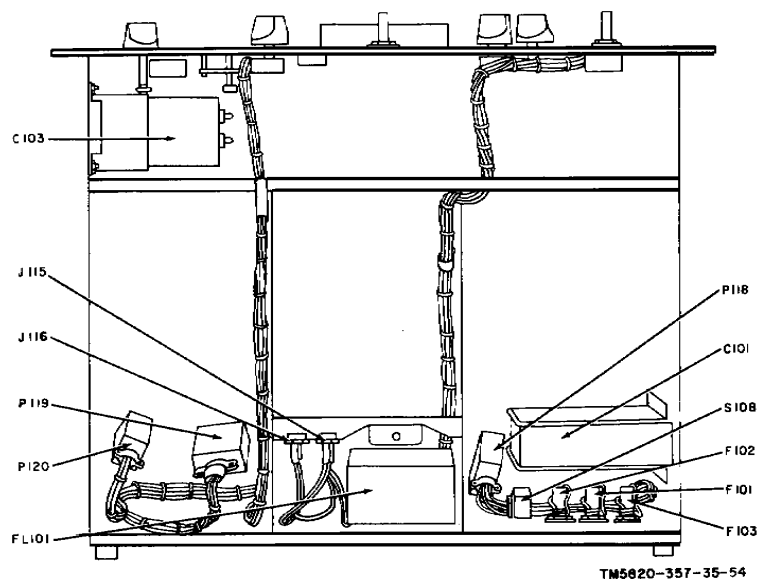

Figure 38. Front panel and main frame, bottom view.

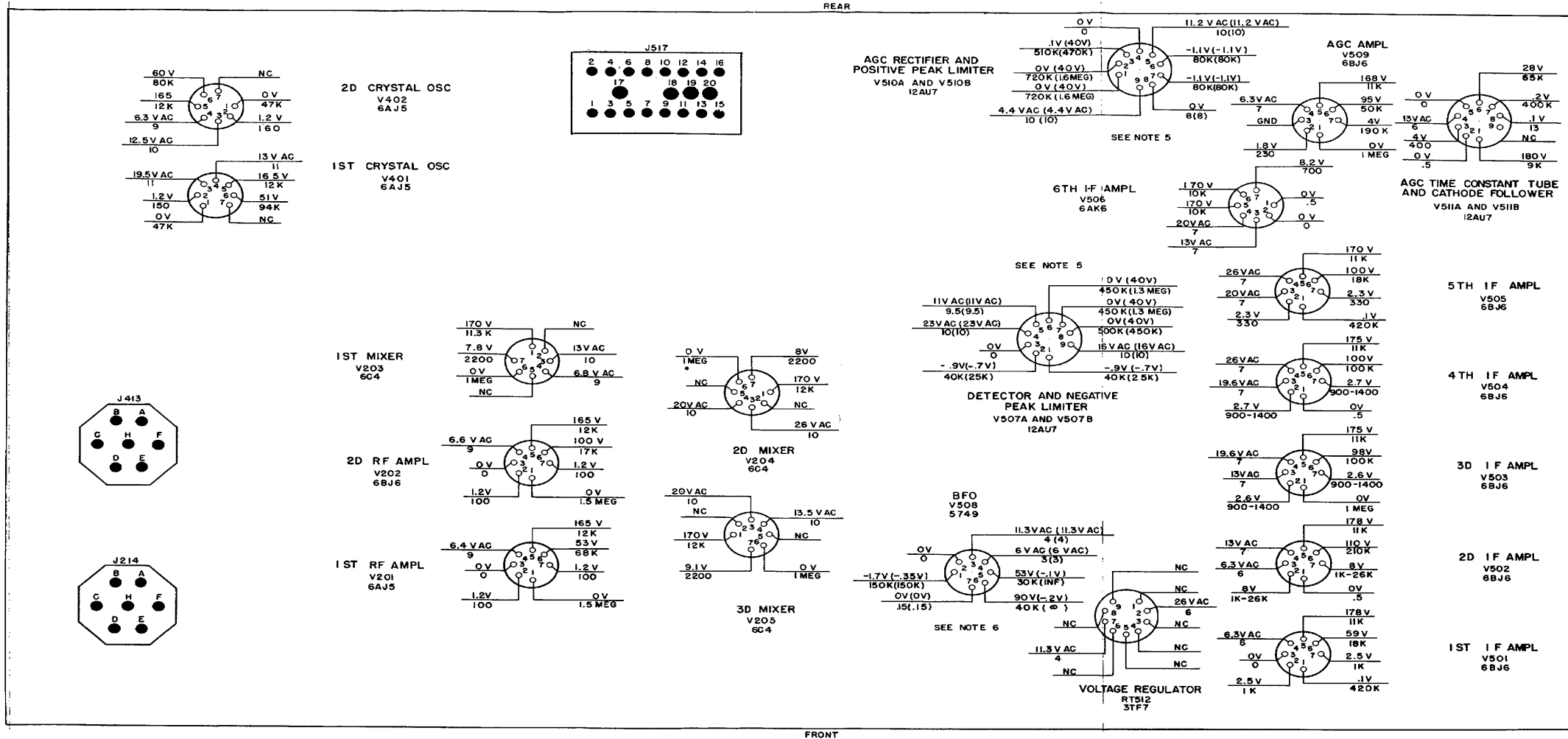

Figure 39. Top deck, voltage and resistance measurements.

## 55. Frequency Conversion Scheme

a. *General.* The frequency conversion scheme of the receiver is covered in chart form in b below. The frequency range of the second variable if is from 2.5 to 2.0 mc for the 0.5 to 1.0-mc band, and from 3.0 to 2.0 mc for all other bands. The frequency range of the vfo is from 3.455 to 2.455 mc for all bands. The fixed if. output of the third mixer is 455 kc. The following is an example of the use of the chart:

Frequency of station being received..... 5.5mc  
 Frequency indicator reading..... 05 500  
 Band..... 5-6  
 Position of switch S201..... 4 me  
 Frequency range of antenna and rf coils..... 4.8 mc

Position of switch S401 .....5  
 First crystal-oscillator crystal frequency .....8 mc  
 First crystal-oscillator Output frequency .....8 mc  
 First variable if. ....13.5mc

*Note:* The first variable if. equals the first crystal-oscillator output frequency plus the frequency of the received signal.

Second crystal-oscillator frequency.....8 mc  
 Second crystal-oscillator output frequency....16 mc  
 Second variable if. ....2.5 mc

*Note:* The second variable if. equals the difference frequency between the second crystal-oscillator output frequency and, the first variable if.

*Note:* The vfo frequency equals the second variable if plus the fixed if output of the third mixer, 455 kc.

### b. Rf and Variable If. Conversion Scheme.

Band (mc)	Position of switch S201	Range of antenna and rf coils (mc)	Position of switch S401	1st xtal-osc crystal frequency (mc) <sup>a</sup>	1st xtal-osc output frequency (mc) <sup>a</sup>	1st variable if. range (mc) <sup>a</sup>	2d xtal-osc crystal frequency (mc)	2d xtal-osc output frequency (mc)
0.5-1	1	0.5-1	0	9	9	9.5-10	12	12
1-2	2	1-2	1	8	8	9-10	12	12
2-3	3	2-4	2	10	10	12-13	15	15
3-4			3	12.6	12.6	15.6-16.6	6.2	18.6
4-5	4	4-8	4	7	7	11-16	14	14
5-6			5	8	8	13-14	8	16
6-7			6	9	9	15-16	9	18
7-8			7	10	10	17-18	10	20
8-9	5	8-16	8				11	11
9-10			9				12	12
10-11			10				13	13
11-12			11				14	14
12-13			12				15	15
13-14			13				8.0	16
14-15			14				8.5	17
15-16			15				9.0	18
16-17	6	16-32	16				9.5	19
17-18		17					10	20
18-19		18					10.5	21
19-20		19					11	22
20-21		20					11.5	23
21-22		21					12	24
22-23		22					12.5	25
23-24		23					13	26
24-25		24					9	27
25-26		25					14	28
26-27		26					9.666	29
27-28		27					10	30
28-29		28					10.333	31
29-30		29					10.666	32
30-31		30					11	33
31-32		31					11.333	34

<sup>a</sup> Not in use after the first eight frequency bands.

## Section III. REPAIRS

### 56. Parts Replacement Techniques

Careless wiring, soldering, end replacement of parts often create new faults; therefore, the following precautions must be observed:

*a.* Before unsoldering a part, note the position of the leads. If the part has a number of connections, tag each lead.

*b.* Be careful not to damage other leads while moving them out of the way.

*c.* Solder all joints carefully. Do not allow drops of solder to fall into the receiver; they may cause short-circuits. A poorly soldered connection is difficult to find.

*d.* When replacing a part in the rf or if. circuits, place it in the same position as the original part. Parts having the same electrical characteristics but different physical size may cause trouble in high-frequency circuits. When replacing a part, use the same ground as in the original wiring. Oscillation or decreased gain may result from failure to observe these precautions.

### 57. Removal and Replacement

All subchassis, except the rf subchassis, can be removed from the receiver without prior removal of any of the other assemblies. When the rf and vfo subchassis are removed from the receiver, avoid changing the positions of the kilocycles and vfo tuning shafts, because synchronization checks will be required. Where possible, preset the receiver control before removing the subchassis. Subchassis mounting (captive) screws are color-coded with green heads. When removing a subchassis, loosen the captive screws enough to free them from the main frame. When replacing a subchassis, properly position the subchassis and start all captive screws before tightening them all the way. Reference designations of the coaxial plugs are marked on bands fastened to the cables. To remove a coaxial plug, press the plug in slightly and twist it counterclockwise to release it; then pull the plug straight out. Where coaxial plugs are not readily accessible, use Tube Puller TL-201 to remove the plugs. Loosen the gear clamp screws *slightly*; otherwise, the clamp screw nuts may drop off. Excessive tightening of the clamp screws may strip

the threads. Fully insert a Bristo wrench to avoid stringing the slots in the screwhead.

### 58. Front Panel

(fig. 40)

*a. Removal.* To reach the wiring and parts on the rear of the front panel, or to prepare for removal of the rf subchassis, proceed as follows:

- (1) Remove the top and bottom dust covers from the receiver.
- (2) Remove the two handles from the front panel by removing the nuts and washers that secure the handles at the rear of the front panel.
- (3) Place wooden blocks under the side-plates of the receiver main frame, at the rear of the front panel, so that the panel is clear of the bench and the receiver is tilted backward.
- (4) Rotate the MEGACYCLE CHANGE and KILOCYCLE CHANGE control knobs fully counterclockwise.
- (5) Position the ANT. TRIM control at -4, and remove the knob.
- (6) Position the BFO PITCH control at 0. Position the BANDWIDTH control at 16 KC. Loosen the collars on the BANDWIDTH and BFO PITCH control shafts.
- (7) Remove the KILOCYCLE; CHANGE and MEGACYCLE CHANGE control knobs.
- (8) Remove the DIAL LOCK and ZERO ADJ. knobs. Loosen the nut on the DIAL LOCK bushings and disengage the lock from the KILOCYCLE CHANGE control locking disk (fig. 40).
- (9) Remove the four flathead Phillips screws that secure the front panel to the main frame.
- (10) Remove the front panel by grasping the edges and drawing it straight away from the receiver. Replace the handles and then place the panel face down on the bench so that it rests on the handles. Be careful not to damage the meter faces or to mar the panel markings.

*b. Replacement.* To replace the front panel, proceed as follows:

- (1) Remove the two handles from the front panel by removing the nuts and washers, at the rear of the front panel, that secure the handles. Be careful not to mar the Amish or damage the meters.
- (2) Grasp the edges of the front panel and carefully place it against the receiver. Place the wooden blocks, used in the procedure in *a* (3) above, under the receiver before replacing the front panel.
- (3) Start each of the four flathead Phillips screws one at a time and then tighten them.
- (4) Reengage the DIAL LOCK in the KILOCYCLE CHANGE control locking disk, and tighten the nut on the DIAL LOCK bushing (*a* (8) above).
- (5) Replace the DIAL LOCK knob.
- (6) Replace the ZERO ADJ. knob. Make sure that the threaded cap on the end of the shaft is rotated clockwise finger-tight. Place the knob on the shaft so that the spring-loaded movable part of the stop mechanism fits into the notch in the knob. Rotate the knob clockwise until the stop is reached. Rotate the knob counterclockwise approximately one-sixteenth of an inch and tighten the set screw.
- (7) Replace the KILOCYCLE CHANGE and MEGACYCLE CHANGE control knobs. If the bushings for the KILOCYCLE CHANGE and MEGACYCLE CHANGE controls have been moved, loosen them before replacing and tightening the front panel. This will aid in aligning the controls to prevent possible binding.
- (8) Tighten the collars on the BANDWIDTH and BFO PITCH control shafts.
- (9) Replace the ANT. TRIM control knob.
- (10) Replace the two handles on the front panel; use the nuts and washers that were removed (*b* (1) above).
- (11) Replace the top and bottom dust covers.

## 59. Rf Subchassis

(fig. 40 and 41)

*a. Removal.* Remove the rf subchassis as follows:

- (1) Disconnect coaxial connector P723 (fig. 42); use Tube Puller TL-201.
- (2) Remove the front panel as described in paragraph 58.
- (3) Remove the offset gear (fig. 43) color-coded green and place it in mesh with the gear train.  
*Note:* The offset gear is used only to maintain synchronization of the gear train when the rf subchassis is removed from receiver. In early production models, the green offset gear is reversed to disengage from the rf gear train.
- (4) Remove coaxial connectors P209, P210, P211, P221, P222, P224, P225, and P226 from their respective jacks. (It may be necessary to temporarily remove V501 and its shield to disengage P226.)
- (5) Remove the dust cover from the top of the rf subchassis and disconnect P114.
- (6) Rotate the KILOCYCLE CHANGE control shaft slightly counter clockwise to the stop position; the frequency indicator reading should be (10-972. (Note the minus sign.)
- (7) Remove the two green 1/2-inch screws that secure the subchassis to the end plate of the main frame. Make sure to use only these screws when replacing the subchassis.
- (8) Loosen the three green captive screws, two at the left-hand corners of the subchassis, and one in the upper right-hand corner.
- (9) Lift the subchassis up and out of the receiver; disengage the Oldham coupler on the crystal-oscillator band switch shaft (fig. 23). The floating disk of the coupler will drop down; do not lose this disk. Place the subchassis on its side or on top of the test bench, but not in such a position that it is supported by the gear train that extends beyond the frame of the subchassis.

*Caution:* When the rf subchassis is removed from the receiver, the tension of the loading springs on both the MEGACYCLE CHANGE control and

KILOCYCLE CHANGE control split gears (counter drive (fig. 43) is relieved, which allows the springs to hang loosely from the gears. Remove the springs and place them in an envelope. The two loading springs of the KILOCYCLE CHANGE split gear are shorter than those of the MEGACYCLE CHANGE split gear.

b. *Replacement* (fig. 40 and 43). Before replacing the rf subchassis, check its synchronization (para 73); then proceed as follows:

- (1) Loosen the front clamp that holds the KILOCYCLE CHANGE control locking disk (fig. 40) and move the disk forward.
- (2) Loosen the Oldham coupler clamp (fig. 42) on the crystal oscillator and move the coupler back.
- (3) Rotate the KILOCYCLE CHANGE and MEGACYCLE CHANGE control shafts fully counterclockwise.
- (4) Place the rf subchassis on the frame in the receiver and loosely tighten the rear left-hand and right-hand green mounting screws.
- (5) Raise the front left side of the rf subchassis by placing a screwdriver between the if. subchassis and the main frame, near the if subchassis.
- (6) Load the large brass split gear (fig. 43) two teeth. Remove the screwdriver ((5) above). The intermediate gear will mesh with the pinion gear (fig. 42).
- (7) Tighten the front and rear left-hand green mounting screws.
- (8) Raise the front side of the rf subchassis with a screwdriver to disengage the driven gear (fig. 43) from the MEGACYCLE CHANGE control drive gear (fig. 42).  
*Caution:* While performing the last step, be sure that the intermediate gear does not disengage from the pinion gear ((6) above).
- (9) Load the MEGACYCLE CHANGE control drive gear by two teeth.

- (10) Remove the screwdriver ((8) above) and mesh the MEGACYCLE CHANGE control drive gear to the driven gear. Tighten the rear right-hand mounting screw.
- (11) Insert the two green mounting screws on the right-hand side of the frame.
- (12) To replace the KILOCYCLE CHANGE control locking disk, engage one-half of the counter drive gear (fig. 42); load the gears two teeth and then engage the front half of the counter drive gear.
- (13) Remove the green offset gear from the gear train and mount it in its position at the upper left part of the rf gear plate.
- (14) Tighten the front clamp on the KILOCYCLE CHANGE control locking disk.
- (15) To check the detent, rotate the MEGACYCLE CHANGE control fully clockwise. The stop must fall where the first two digits on the frequency indicator read approximately halfway between 31 and 32.
- (16) Set the MEGACYCLE CHANGE control so that the Oldham coupler (fig. 42) protrusion is horizontal. Slide on the removable disk and mate the rear disk to the removable disk.
- (17) Check the reading on the crystal-oscillator band switch position indicator (fig. 23). See that it agrees with the reading on the megacycle portion of the frequency indicator. If it does not, turn the SYNC XTAL OSC control (TM 11-5820-357-10) until the two readings correspond.
- (18) Tighten the Oldham coupler rear clamp.
- (19) Reconnect P209, P210, P221, P222, P224, P225, and P226.
- (20) Reconnect P114 and replace the dust cover over the rf subchassis.
- (21) Reconnect P723 (fig. 42).
- (22) Replace the front panel (para 58b).
- (23) Recheck the synchronization (para 73).
- (24) Check the vfo tuning shaft synchronization (para 73).

## 60. Crystal-Oscillator Subchassis

(fig. 41)

*a. Removal.* To remove the crystal-oscillator subchassis, proceed as follows:

- (1) Remove the top dust cover from the receiver.
- (2) Disconnect plugs P113, P221, and P222 on the crystal-oscillator subchassis.
- (3) Remove the cover from the top of the crystal-oscillator subchassis.
- (4) Rotate the MEGACYCLE CHANGE control until the setscrew in the clamp of the crystal-oscillator band switch coupler is accessible. Loosen the setscrew and push back the flange.
- (5) Remove the two green, 5/16-inch screws that secure the subchassis to the receiver rear panel.
- (6) Loosen the two green captive screws inside the subchassis, one near tube V401 and the other near the point where the switch shaft enters the subchassis.
- (7) Lift the subchassis straight up from the receiver. The floating disk of the Oldham coupler will drop down; put this disk in a small envelope properly labeled.

*b. Replacement.* To replace the crystal-oscillator subchassis, proceed as follows:

- (1) Lightly coat the coupler flange on the crystal-oscillator band switch drive shaft (located on the rf subchassis) with grease. Place the floating disk against the grease-coated surface of the flange. The grease will hold the disk in place until the flanges of the coupler are mated.
- (2) Carefully lower the subchassis into place and start the two green captive screws.
- (3) Replace the 5/16-inch green captive screws in the rear panel; tighten the screws. Make sure that only these screws are used. Longer screws will cause a short circuit.  
*Caution:* Do not exert force when tightening the screws; excessive force may break the spot weld that secures the subchassis to the subassembly side panel.
- (4) Make sure that the ridges on the Oldham coupler flanges are positioned 90° apart, and that the number showing on the crystal-

oscillator band switch position indicator (below J422) agrees with the megacycle reading on the frequency indicator. Mate the flanges and tighten the clamp.

- (5) Replace the crystal-oscillator subchassis cover.
- (6) Reconnect plugs P113 and P221.
- (7) Replace the dust cover.
- (8) Check the synchronization of the crystal oscillator (para 73).

## 61. If. Subchassis

(fig. 40 and 41)

*a. Removal.* To remove the if subchassis, proceed as follows:

- (1) Remove the top dust cover from the receiver.
- (2) Rotate the BANDWIDTH control to reach the clamp that secures the control shaft at there at the panel. Make a note of the position of the control.
- (3) Set the BFO PITCH control at 0.
- (4) Loosen the clamp setscrews on the BANDWIDTH and BFO PITCH control shafts, and uncouple the shafts by pulling outward on the control knobs.
- (5) Disconnect coaxial connectors P225, P226, P112, and P117.
- (6) Loosen the three green captive screws, one at the front center of the subchassis and two at the rear corners.
- (7) Lift the subchassis straight up from the receiver. Do not disturb the positions of the BANDWIDTH and BFO PITCH tuning shafts after the subchassis is removed from the receiver.

*b. Replacement.* To replace the if. subchassis, proceed as follows:

- (1) Lower the subchassis straight down into the receiver.
- (2) Tighten the three green captive screws.
- (3) Reconnect plug P117 (fig. 41).
- (4) Reconnect coaxial connectors P225, P226, and P112.
- (5) Tighten the clamp screws on the BANDWIDTH and BFO PITCH control shafts, and couple the shafts by

pushing inward on the control knobs.

*Note:* Before recoupling the BANDWIDTH and BFO PITCH control shafts, be sure that the controls are set at the positions noted during removal.

- (6) Replace the top dust cover.

## 62. Power Supply PP-621/URR (fig. 42)

*a. Removal.* To remove the power supply subchassis, proceed as follows:

- (1) Remove the bottom dust cover.
- (2) Disconnect P118.
- (3) Loosen the two captive screws that are accessible through holes indicated by arrows marked MTG SCREWS INSIDE.
- (4) Loosen the green captive screw in the corner of the subchassis near tube V802.
- (5) Remove the four green, 7/16-inch screws that secure the power transformer to the side of the main frame.
- (6) Lift the subchassis straight up from the receiver.

*Caution:* The power supply is heavy; be careful not to drop it.

*b. Replacement.* To replace the power supply subchassis, proceed as follows:

- (1) Carefully lower the subchassis into the receiver.
- (2) Tighten the green captive screw in the corner of the subchassis near tube V802.
- (3) Replace and tighten the four green 7/16-inch screws that secure the power transformer to the side of the main frame. Use screws only of this size.
- (4) Tighten the two hidden captive screws through the holes in the power supply mounting bracket (fig. 42).
- (5) Reconnect large connector P118 and J818.
- (6) Replace the bottom dust cover.

## 63. Vfo Subchassis (fig. 42)

*a. Removal.* To remove the vfo subchassis, proceed as follows:

- (1) Remove the bottom dust cover from the receiver.
- (2) Disconnect plug P715, coaxial connector

P723, J115, and J223. Use Tube Puller TL-201 for removing P723.

- (3) Remove the small loading spring from the Oldham coupler on the vfo tuning shaft. To avoid loss of the spring, put it in a small marked envelope.
- (4) Rotate the KILOCYCLE CHANGE control so that the ridge in the flange of the coupler nearest the vfo subchassis is vertical.

*Note:* If synchronization of the Vfo boning shaft and the KILOCYCLE CHANGE control is to be maintained, do not disturb the position of the shaft during the succeeding steps, or after the vfo subchassis has been removed.

- (5) Loosen the two green captive screws in the front mounting bracket of the subchassis and the green captive screw in the rear mounting bracket.
- (6) Carefully remove the subchassis from the receiver; lift it straight up to disengage the Oldham coupler, and then tilt it slightly to clear the receiver. The floating disk will drop down from the coupler; place the disk in a marked envelope.

*Caution:* The sealed can (vfo) should not be opened under any circumstance. The tuning unit was accurately adjusted under laboratory conditions during manufacture. Any attempt to perform adjustments under other conditions will seriously affect the accuracy of the unit.

*b. Replacement.* To replace the vfo subchassis, proceed as follows:

- (1) If the position of the vfo tuning shaft has been disturbed while the subchassis was removed from the receiver, or if a new vfo is to be installed, synchronize the shaft as described in paragraph 73.
- (2) If the position of the shaft has not been disturbed, place the floating disk on the flange of the vfo drive shaft. Position the ridge on the coupler flange of the vfo tuning shaft 90° from that of the flange on the drive shaft, and carefully insert the vfo subchassis into place. Tilt it slightly to clear the receiver frame.
- (3) Tighten the three green screws on the subchassis mounting brackets.

- (4) Replace the loading spring on the Oldham coupler.
- (5) Connect P715 to J115 and P723 to J223 (fig. 42). (See the note below.)
 

*Note:* Plug P916 and its associated jack J116 are marked with a red dot. To prevent accidental transposition of plug P715 and plug P916, however, some receivers do not have this identification. Inspect the plugs before removal and mark them for identification when necessary. Plug P916 can be identified by its four conductors; vfo plug P715 has five conductors.
- (6) Replace the bottom dust cover on the receiver.
- (7) If the vfo setting has been disturbed, refer to paragraph 73 for synchronization procedures

#### 64. Calibration-Oscillator Subchassis (fig. 42)

*a. Removal.* To remove the calibration-oscillator subchassis, proceed as follows:

- (1) Remove the bottom dust cover from the receiver.
- (2) Disconnect plugs P715 and P916.
- (3) Disconnect coaxial connector P224 on the top deck of the receiver (fig. 41).
- (4) Loosen the two green captive screws at opposite ends of the subchassis.
- (5) Carefully lift the subchassis out of the receiver.

*b. Replacement.* To replace the calibration oscillator subchassis, proceed as follows:

- (1) Carefully lower the subchassis into the receiver.
- (2) Tighten the two green captive screws at opposite ends of the subchassis.
- (3) Connect coaxial connector P224 on the top deck of the receiver (fig. 41).
- (4) Reconnect plugs P715 and P916.
- (5) Replace the bottom dust cover.

#### 65. At Subchassis (fig. 42)

*a. Removal.* To remove the al subchassis, proceed as follows:

- (1) Remove the bottom dust cover from the receiver.
- (2) Disconnect plugs P119 and P120 (fig. 42).
- (3) Remove the screw from the cable clamp that

secures the cable at the side of the at subchassis.

- (4) Loosen the screw in the clamp that secures the cable to the casting at the af subchassis front end, and swing the clamp free from the cable.
- (5) Loosen the three green captive screws, one at the front end of the subchassis and two at the rear corners.
- (6) Move the cable from which the clamps were moved, lift the subchassis straight up, and then tilt the front down slightly to remove the subchassis from the receiver.

*b. Replacement.* To replace the at subchassis, proceed as follows:

- (1) Carefully replace the subchassis by lowering it straight down into the receiver. The front end may have to be tilted slightly.
- (2) Tighten the three green captive screws, one at the front end of the subchassis and two at the rear corners.
- (3) Place the cable in position on the casting; then replace the clamp to secure the cable. Tighten the screw on the clamp.
- (4) Replace and tighten the screw that secures the cable clamp to the side of the af subchassis.
- (5) Reconnect plugs P119 and P120 (fig. 42).
- (6) Replace the bottom dust cover.

#### 66. Rf Tuning Coils and Transformers (fig. 20)

*a. Removal.* To remove the rf tuning coils and transformers, proceed as follows:

- (1) Remove the slug rack associated with the coil or transformer by unhooking the spring located at each end of the rack; then use a bent paper clip hooked through the end of the spring to anchor the spring temporarily to the end plates of the subchassis. Be careful that the springs do not fall into the subchassis.
- (2) Insert a Phillips screwdriver (rear panel of receiver, TM11-5820-357-10) into each of the two holes in the coil or transformer can; loosen the screws until they are free from the subchassis.
- (3) Withdraw the coil or transformer from the subchassis.

*b. Replacement.* To replace the rf tuning coils and transformers, proceed as follows:

- (1) Plug the coil or transformer into its socket.
- (2) Replace the two small Phillips screws into the holes in the coil or transformer can and tighten them.
- (3) Carefully remove the two springs from the end plates.
- (4) Replace the slug rack and replace the two springs; be careful that they do not fall into the subchassis.

Note: Beginning with rf subchassis MOD 2, the cores of antenna coils T201 through T206 are made of different material to improve tracking. The cores of tuning circuits Z206, Z212, and Z218 are smaller to increase the tuning range of the high-frequency band. Coils or transformers that have identical functions are interchangeable for all models, provided the change is complete with tuning cores; however, when a tuning core is replaced, the correct one of the two types available must be selected for proper operation of the coil.

## 67. Antenna Box

(fig. 41)

*a. Removal.* To remove the antenna box, proceed as follows:

- (1) Disconnect coaxial connector P209, P210, and P211 (fig. 41).
- (2) Unsolder the leads from the winding of antenna relay K101.
- (3) Remove the three screws that secure the antenna box to the rear panel of the receiver.

*b. Replacement.* To replace the antenna box, proceed as follows:

- (1) Place the antenna box in position and replace and tighten the three screws.
- (2) Resolder the leads to the winding of K101. Be careful not to drop solder into the box.
- (3) Reconnect P211, P210, and P209.

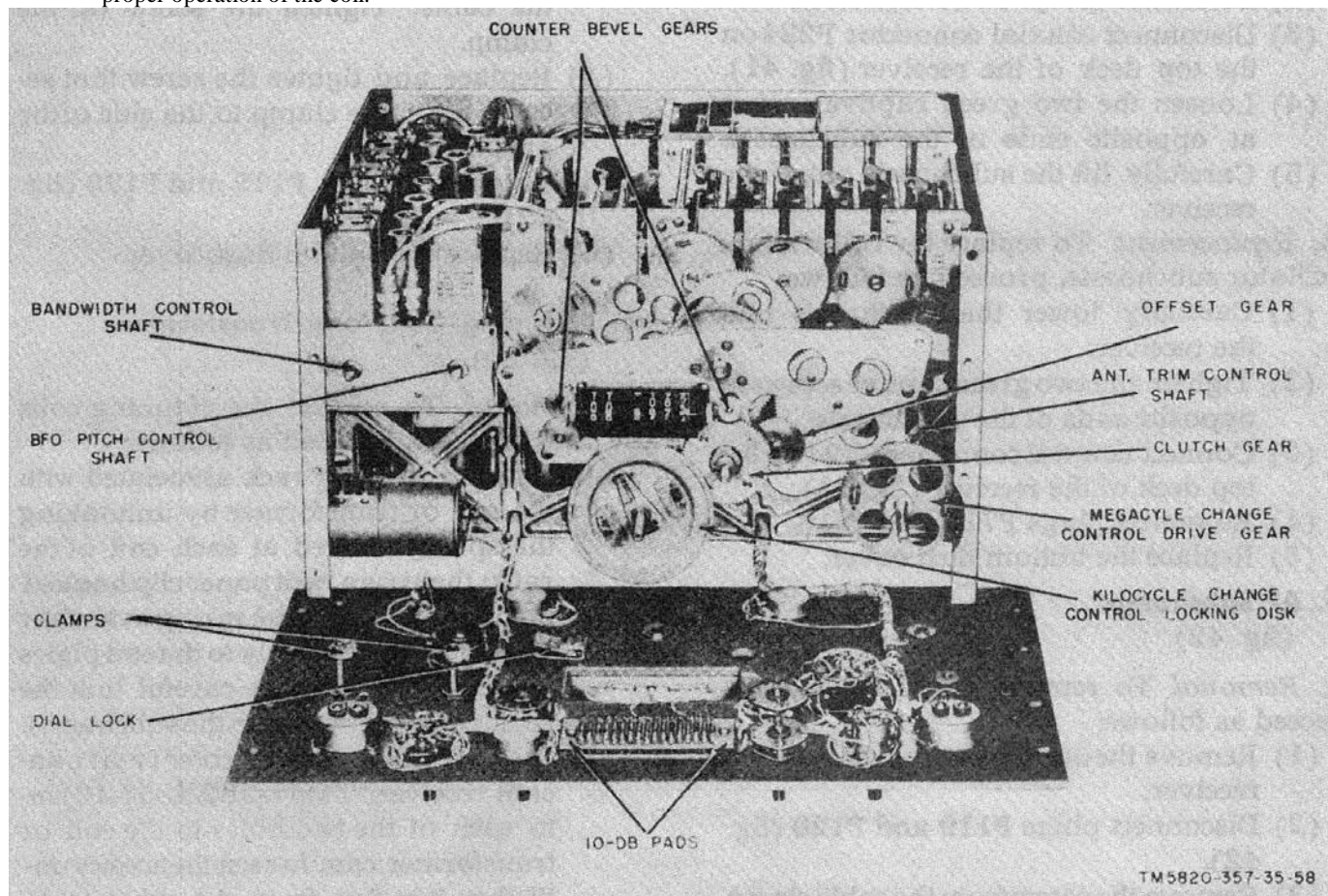

Figure 40. Receiver, front panel removed.

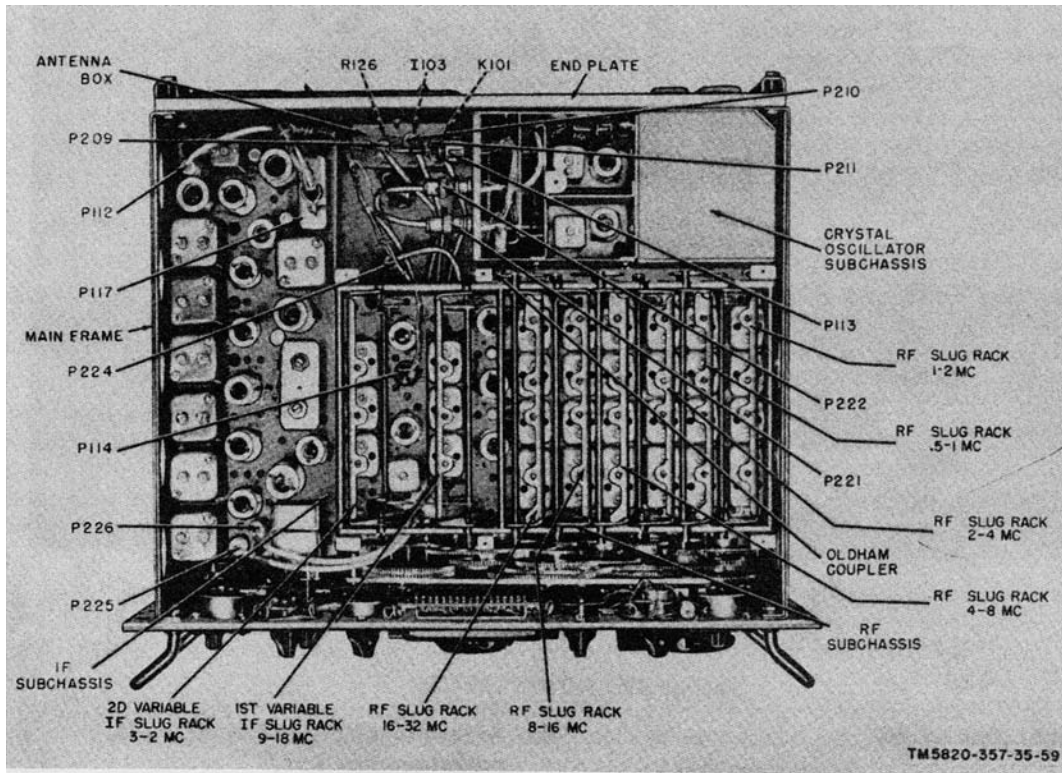

Figure 41. Receiver, top view, dust cover removed.

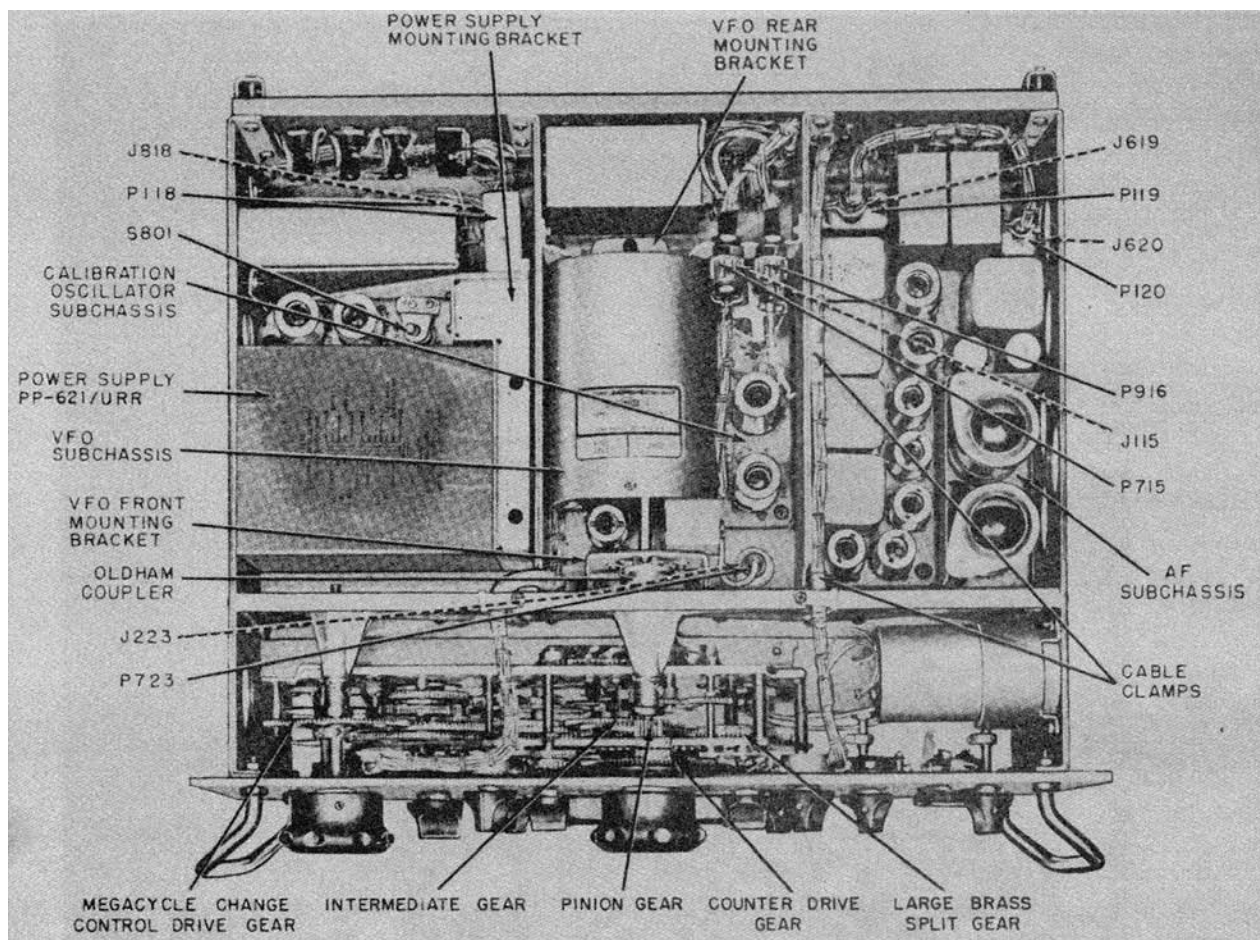

Figure 42. Receiver, bottom view, dust cover removed.

## Section IV. ADJUSTMENTS

### 68. Calibration of Bfo

The bfo should be calibrated after the front panel or if. subchassis is replaced. To calibrate the bfo, proceed as follows:

- a. Set the BANDWIDTH switch to .1, and turn the FUNCTION switch to CAL.
- b. Connect the headset to the PHONES jack. Adjust the KILOCYCLE CHANGE control for maximum response on the CARRIER LEVEL meter at any 100-kc calibration checkpoint.
- c. Set the BFO switch to ON, and adjust the BFO PITCH control for zero beat; zero beat should occur at the position of the control marked 0. If not, loosen the setscrew and position the knob at 0. Tighten the setscrew.

### 69. Adjustment of CARP-METER ADJ potentiometer R537 (fig. 25)

To set the CARRIER LEVEL meter pointer at zero, set CARP-METER ADJ potentiometer R537 as follows:

- a. Set the FUNCTION switch to AGC.
- b. Rotate the RF GAIN control extremely counterclockwise.
- c. Adjust CARP-METER ADJ potentiometer R357 for a reading of 0 on the CARRIER LEVEL meter.

### 70. Adjustment of Calibration Oscillator (fig. 42)

To adjust the calibration oscillator, proceed as follows:

- a. Set the BANDWIDTH switch to 1.
- b. Set the AUDIO RESPONSE switch to MED.
- c. Connect a headset into the PHONES jack.
- d. Turn the FUNCTION switch to CAL, and rotate the KILOCYCLES CHANGE control through a minimum of ten 100-kc steps. If a note is not heard exactly at the 100-kc steps, adjust capacitor C912. Check at least 100-kc positions to make sure that a note is heard in 100-kc steps.
- e. Connect an antenna to the receiver, set the FUNCTION switch at AGO, and tune in station WWV at 2.5, 5, 10, 15, 20 me whichever is stronger.
- f. Turn the BFO switch to ON and set the BFO PITCH control to 0.
- g. Adjust the KILOCYCLE CHANGE control to zero beat with station WWV.
- h. Turn the FUNCTION switch to CAL.
- i. Disconnect the antenna from the receiver.
- j. Adjust capacitor C901 for a zero beat in the headset.

## 71. Adjustment of GAIN ADJ Potentiometer R562 (fig. 25)

An overall gain measurement (*a* below) will indicate whether adjustment of R562 is necessary.

### *a. Measuring Overall Gain.*

- (1) Connect the receiver to an ac power source and allow it to warm up.
- (2) Set the receiver BANDWIDTH switch to 8, the FUNCTION switch to MGC, the RF-GAIN control to 10, and the BFO switch to OFF.
- (3) Connect the TS-505(\*)/U between DIODE LOAD terminal 14 on the rear terminal strip of the receiver and ground (TM 11-0820-357-10).
- (4) Set the TS-505(\*)/U on the negative 10-volt dc range.
- (5) Connect RF Signal Generator AND URM-25(\*) through the dummy antenna, Connector UG-971/U, and Adapter Connector UG-636/U to BALANCED 125 OHM ANTENNA jack J108 located on the rear of the receiver.

- (6) Adjust the AN/URM-25(\*) for an unmodulated output at 6.0 me.
- (7) Tune the receiver to 6.0 me.
- (8) Adjust the AN/URM-25(\*) output attenuator for an indication of -7.0 volts on the TS-505(\*)/U.
- (9) An AN/UR-25(\*) output of between 1 and 4 microvolts indicates normal receiver gain. If more than 4 microvolts are required, adjust R562 as explained in *b* below.

### *b. Adjusting GAIN ADJ Potentiometer R562.*

- (1) Disconnect P225 and P226 (fig. 41).
- (2) Connect the AN/URM-25(\*) through Network, Impedance Matching CU-406/URM-25F, part of the AN/URM-25(\*), to J525 (fig. 26) on the receiver chassis.
- (3) Connect the TS-505(\*)/U between the DIODE LOAD terminal on the rear terminal strip of the receiver and ground (TM 11-5820-334-10).
- (4) Set the TS-605(\*)/U on the negative 10-volt range.
- (5) Connect the receiver to an ac power source and allow it to warm up.
- (6) Set the receiver BANDWIDTH switch to 8, FUNCTION switch to (MGC, RF GAIN control to 10, and BFO switch to OFF.
- (7) Adjust the AN/URM-25(\*) for an unmodulated 455-kc output signal at 160 microvolts.
- (8) Adjust GAIN ADJ potentiometer R562 for a -7.0-volt indication on the TS-505(\*)/U.
- (9) If the -7.0-volt indication cannot be obtained after a maximum adjustment of R562, check the i.f. amplifier tubes by using Test Set, Electron Tube TV-7(\*)/U. Replace any bad or shorted tubes; then replace the weakest tubes, one at a time, until a -7.0-volt indication can be obtained.

*Note:* It may not be possible to obtain -7.0 volts at the diode load of the receiver with an input of 150 microvolts at J525 after replacing all weak tubes. In this case, R562 should be adjusted so the -7.0 volts can be obtained with not less than 100-microvolt or more than 200-microvolt input at J525.

## CHAPTER 3

### FOURTH ECHELON MAINTENANCE

---

#### Section I. REPAIRS AND ADJUSTMENTS

#### 72. Rf Gear Train Disassembly and Reassembly (fig. 73)

Under certain circumstances, such as extensive damage or mechanical failure, it may be necessary to disassemble all or part of the rf gear train assembly. The instructions given in this paragraph should be used when the method of removal of the parts is not obvious. The index numbers used in the instructions refer to those that identify the parts in figure 73. When disassembling the rf gear train in assembly, mark the individual gears with the index number. This will aid in identification and reassembly. Place the parts in trays or containers in the order of disassembly to simplify the reassembly procedure.

*a. Disassembly.* To disassemble the rf gear train assembly, proceed as follows:

- (1) Remove the front panel (para 58).
- (2) Remove the rf subchassis (para 59).
- (3) Remove the 8 slug racks and the 16 tension springs. Tag the slug racks for identification according to frequency.
- (4) Loosen the 5/16-inch hexagonal nut (1) and 5/16-inch lockwasher (2) and remove the 6-32 by 5/16-inch Phillips head screw (3) and the No. 6 lockwasher (4). To remove the clutch gear assembly (which consists of part 5 through 21), remove the 5/16-inch hexagonal nut (1) and the 5/16-inch lockwasher (2). To disassemble the clutch gear assembly, follow the procedures in (a) and (b) below. If it is not necessary to disassemble the clutch gear assembly, proceed with (5) below.
- (a) Remove the 0.395-inch retaining ring (5), steel split gear assembly (6), 7/16-inch flat washer (7), four 17/32-inch spring friction washers (8), two 7/16-inch flat

washers (9), steel plate (10), four clutch plates (11), and brass gear (12).

- (b) Remove the zero adjust shaft (13), the 0.225-inch retaining ring (14), stop washer (15), spring holder (16), stop spring (17), flat pin (18), 1/4-inch washer (19), 0.225-inch retaining ring (20), end steel bushing (21) from the clutch assembly shaft (22).
- (5) Remove the four 4-40 by 5/16-inch Phillips head screws (23) and four No. 4 split lockwashers (24) to remove the mechanical counter (25).
- (6) Remove the beveled gear (26) and gear clamp (27) by loosening the 3-56 by 1/4-inch Bristo head screw (28).
- (7) Remove the brass beveled gear (29) and gear clamp (30) by loosening the 3-56 by 1/4-inch Bristo head screw (31).
- (8) Remove the two beveled gear assemblies (32) and (33).
- (9) Remove the 6-32 by 3/16-inch Phillips head screw (34) and No. 6 lockwasher (35) and green-faced gear (36).
- (10) Remove the 0.207-inch retaining ring (37) and the brass gear (38).
- (11) Remove the 0.207-inch retaining ring (39) and remove the hollow pin (40) from the brass gear (41). Pull out the brass gear and shaft assembly (42) while sliding off the brass gear (41) and 3/16-inch washer (43).
- (12) Remove the 6-40 by 5/16-inch machine screw (44).
- (13) Remove the rf gear train front plate assembly (45) by removing the three 8-32 by 5/16-inch Phillips head screws (46) and the three No. 6 lockwashers (47).
- (14) Remove the 0.225-inch retaining ring

- (48) and pull out the welded gear and shaft assembly (49) from the rear of the rf gear train front plate assembly (45).
- (15) Remove the 0.122-inch retaining ring (60) to remove the large brass gear (51).
  - (16) Remove the three 6-32 by 1/4-inch Phillips head screws (52) and the three No. 6 lockwashers (63) that hold the triangular steel plate (54) to the rf gear front plate assembly (45).
  - (17) Remove the 0.122-inch retaining ring (55) and remove the pinned steel split gear assembly (56) and 5/16-inch steel washer (57).
  - (18) Remove the two 6-32 by 1/4-inch Phillips head screws (58) and the two No. 6 lockwashers (59) that hold the detent spring (60).
  - (19) Remove the differential gear assembly (61 through 72). To disassemble the differential gear assembly, follow the procedures given in (a) through (e) below. If it is not necessary to disassemble the differential gear, proceed with (20) below.
    - (a) Remove the three 4-40 by 1/4-inch Phillips head screws (61) and the three No. 4 lockwashers (62).
    - (b) Gently lift off the pinned gear assembly (63).
    - (c) Remove the three 0.122-inch retaining rings (64) and remove the three identical brass split gear assemblies (65).
 

*Note:* The third brass gear assembly is shown exploded with index numbers (66 through 69) in figure 63.
    - (d) Remove the 0.395-inch retaining ring (66) and separate the flat brass gear (67), the steel loading spring (68), and the pinned brass and steel gear assembly (69).
    - (e) Remove the 0.395-inch retaining ring (70) to facilitate the removal of loading springs (71) on pinned split gear and detent assembly (72).
  - (20) Remove the pinned large brass split gear assembly (73) and 3/16-inch washer (74).
  - (21) Remove the steel split gear assembly (76 through 79) and the 3/16-inch steel washer (75) and dismantle the assembly by removing the 3/16-inch retaining ring (76) that separates the steel gear (77), the aluminum separator (78), and the steel gear (79).
  - (22) Remove the 0.281-inch retaining ring (80) to remove the large brass gear assembly (81).
  - (23) Remove the large brass gear (82) by loosening the 4-40 by 9/16-inch Bristo head screw (83) and the 4-40 square nut (84) on the gear clamp (86).
  - (24) Remove the small steel gear (86) by loosening the 4-40 by 9/16-inch Bristo head screw (87) and the 4-40 square nut on gear clamp (89).
  - (25) Remove the 0.122-inch retaining ring (90) to remove the brass gear (91).
  - (26) Loosen the 4-40 by 9/16-inch Bristo head screw (92) and the 4-40 square nut (93) on the gear clamp (94) to remove the steel gear (95) and the steel split gears (96). To disassemble the split gears, remove the three 4-40 by 1/4-inch Phillips head screws (97).
  - (27) Loosen the 4-40 by 9/16-inch Bristo head screw (98) and the 4-40 square nut (99) on the gear clamp (100) to remove the small steel gear (101) and the large steel split gear (102).
  - (28) Loosen the 4-40 by 9/16-inch Bristo head screw (103) and the 4-40 square nut (104) on the gear clamp (105) to remove the steel split gear (106).
  - (29) Loosen the 4-40 by 9/16-inch Bristo head screw (107) and the 4-40 square nut (108) on the gear clamp (109) to remove the steel split gear (110) and the small steel gear (111).
  - (30) Remove the three 4-40 by 1/4-inch Phillips head screws (112) to remove the steel split gear assembly (113).
  - (31) Remove the No. 6/0 taper pin (114) to remove the first variable if. rear cam (115). Pull the camshaft (116) out through the front of the rf subchassis and remove the cam and gear assembly (117) by removing the No. 6/0 taper pin (118).
  - (32) Loosen the 4-40 by 9/16-inch Bristo

- head screw (119) and the 4-40 square nut (120) and the gear clamp (121) to remove the steel split gear (122).
- (33) Loosen the 4-40 by 9/16-inch Bristo head screw (123) and the 4-40 square nut (124) on the gear clamp (125) to remove the steel split gear (126).
  - (34) Remove the 8-32 by 5/16-inch Phillips head screw (127) and the No. 8 lock washer (128) to remove the Geneva system and overtravel coupler. Separate the gear assembly by removing the steel plate (129), the 3/16-inch steel ball (130), and the 10-tooth lost motion gear (131). Remove the 0.122 inch retaining ring (132) and the 3/16-inch washer (133) to separate the brass gear (134) and the steel shaft (135).
  - (35) Remove the 6-32 hexagonal nut (136) and No. 6 lockwasher (137). Remove the 3/32-inch retaining ring (138) and separate the steel eight-tooth and four-tooth gear (139) and the steel shaft (140) from the gear train assembly rear plate (146).
  - (36) Remove the 6-32 by 5/16-inch hexagonal head screw (141) and the No. 6 lockwasher (142). Remove the 0.122-inch retaining ring (143) and separate the brass gear (144) and steel shaft (145) from the gear assembly rear plate (146).
  - (37) Remove the 0.225-inch retaining ring (147). Loosen the 4-40 by 5/16-inch Bristo head screw (148) and 4-40 square nut (149) to loosen the gear clamp (150). Separate the rf band switch shaft (151) from the steel gear (152).
  - (38) Remove the two 6-32 by 3/16-inch Phillips head screws (153) and No. 6 lockwashers (154) to loosen the flange (155). Remove the steel gear and shaft assembly (156). Remove the hollow pin (157) to separate the Oldham coupler (158), flange (155), and 3/16-inch washer (159) from the steel gear and shaft assembly (156).
  - (39) Remove the No. 6/0 taper pin (160) and the second variable if. cam (161). Remove the No. 6/0 taper pins (162 and 164) to loosen the second variable if. cams (163) and (165). Remove the camshaft (166). Remove the No. 6/0 taper pin (167) and the second variable if. cam (168).
  - (40) Remove the No. 6/0 taper pin (169) and the cam (170) to remove the camshaft (171). Remove the No. 6/0 taper pin (172) and the 16- to 32-mc rf cam (173).
  - (41) Remove the No. 6/0 taper pin (174) and the steel gear and brass cam assembly (175) to remove the camshaft (176). Remove the No. 6/0 taper pin (177) and the 8- to 16-mc rf cam (178).
  - (42) Remove the No. 6/0 taper pin (179) and the 4- to 8 mc rf cam (180) to remove the camshaft (181). Remove the No. 6/0 taper pin (182) and the 4- to 8-me rf cam (183).
  - (43) Remove the No. 6/0 taper pin (184) and the 2- to 4-me rf cam (185) to remove the camshaft (186). Remove the No. 6/0 taper pin (187) and the 2-to 4-me rf cam (188).
  - (44) Remove the No. 6/0 taper pin (189) and the 0.5- to 1 -me rf cam (190) to remove the camshaft (191). Remove the No. 6/0 taper pin (192) and the 0.5- to 1-me rf cam (193).
  - (45) Remove the No. 6/0 taper pin (194) and the 1- to 2-me rf cam (195) to remove the camshaft (196). Remove the No. 6/0 taper pin (197) and the 1- to 2-me rf cam (198).
  - (46) Loosen the four 8-32 by 3/32-inch Bristo head screws (199) and remove the 1/4-inch coupler (200) and the 1/4- inch fiber shaft (201). Remove the 3/8-32 hexagonal head nut (202), 3/8-inch lockwasher (203), 3/8-inch flat washer (204), and the 3/8-inch insulated washer (205).
  - (47) Remove the six 6-32 by 3/8-inch Phillips head screws (206) and the six No. 6 lockwashers (207) that hold the three L-brackets (208) and the three bracing rods (209) to the gear train assembly rear plate (146).
  - (48) Remove the three 8-32 by 3/8 inch

hexagonal head screws (210) and the three No. 8 lockwashers (211).

(49) Remove the three 8-32 by 1/4-inch flathead Phillips head screws (212) that hold the three separator rods (213).

(50) Remove the two 8-32 by 3/8-inch hexagonal head screws (214) and the two No. 8 lockwashers (215). Remove the 8-32 by 1/4-inch flathead Phillips head screw (216) and the No. 8 lockwasher (217) to remove the rf subchassis rear plate (218).

*b. Reassembly.* To reassemble the rf gear train assembly, proceed as follows:

(1) Replace the rf subchassis rear plate (218) and secure it with the 8-32 by 1/4-inch flathead Phillips head screw (216), the No. 8 lockwasher (217), the two 8-32 by 3/8-inch hexagonal head screws (214) and two No. 8 lockwashers (215).

(2) Replace the three separator rods (213) by inserting the three 8-32 by 1/4-inch flathead Phillips head screws (212).

(3) Replace the three 8-32 by 3/8-inch hexagonal head screws (210) and No. 8 lockwashers (211).

(4) Attach the three L-brackets (208) and the three bracing rods (209) to the gear train assembly rear plate (146); use the six 6-32 by 3/8-inch Phillips head screws (206) and the six No. 6 lockwashers (207).

(5) Replace the 3/8-inch insulated washer (205), 3/8-inch flat washer (204), 3/8-inch lockwasher (203), 3/8-32 hexagonal head nut (202), 1/4-inch coupler (200), and the 1/4-inch fiber shaft (201), and tighten the four 8-32 by 3/32-inch Bristo head set-screws (199).

(6) Replace the 1- to 2-me rf cam (198) and insert the No. 6/0 taper pin (197). Replace the camshaft (196), the 1- to 2-me rf cam (195), and insert the No. 6/0 taper pin (194).

(7) Replace the 0.5 to 1-me rf cam (193) and insert the No. 6/0 taper pin (192). Replace the cam shaft (191), the 0.5- to 1-me rf cam (190), and insert the No. 6/0 taper pin (189).

(8) Replace the 2- to 4-me cam (188) and insert the No. 6 taper pin (187). Replace the camshaft (186), the 2- to 4-me rf cam (185), and insert the No. 6/0 taper pin (184).

(9) Replace the 4- to 8-me rf cam (183) and insert the No. 6/0 taper pin (182). Replace the camshaft (181), the 4- to 8-me rf cam (180), and insert the No. 6 taper pin (179).

(10) Replace the 8- to 16-me rf cam (178) and insert the No. 6/0 taper pin (177). Replace the camshaft (176), the steel gear and brass cam assembly (175), and insert the No. 6/0 taper pin (174).

(11) Replace the 16- to 32-me rf cam (173) and insert the No. 6/0 taper pin (172). Replace the camshaft (171), the 16- to 32-me rf cam (170), and insert the No. 6 taper pin (169).

(12) Replace the second variable if cam (168) and insert the No. 6/0 taper pin (167). Replace the camshaft (166) through the rf subchassis rear plate (218). Replace the second variable if cam (165) when the camshaft barely protrudes through the rf subchassis rear plate (218), and replace the other second variable if cam (163) when the camshaft is close to the gear train assembly rear plate (146). Insert the No. 6/0 taper pins (164) and (162). Replace the second variable if cam (161) and insert the No. 6/0 taper pin (160).

(13) Replace the 3/16-inch steel washer (159), the flange (155), and the Oldham coupler (158) on the steel gear and shaft assembly (156). Insert the hollow pin (157). Replace the steel gear and shaft assembly (156) in the rf subchassis. Replace the two 6-32 by 3/16-inch Phillips head screws (153), and the No. 6 lockwashers (154), through the flange (155), and tighten to subchassis.

(14) Replace the 1-1/16-inch diameter steel gear (152) on the rf band switch shaft (151). Tighten the 4-40 by 5/16-inch Bristo head screw (148) and the 4-40 square nut (149) on the gear clamp

- (150). Replace the 0.225-inch retaining ring (147).
- (15) Replace the brass gear (144) on the steel shaft (145) and fasten it with the 0.122-inch retaining ring (143). Position this assembly on the gear train assembly rear plate (146) as shown in figure 74. Fasten it to the year train assembly rear plate (146) with the 6-32 by 5/16-inch hexagonal head screw (141) and the No. 61 lockwasher (142).
  - (16) Replace the small steel gear (139) on the steel shaft (140) and fasten it with the 3/32-inch retaining ring (138). Position this assembly as shown in figure 74 and fasten it with the 6-32 hexagonal nut (136) and the No. 6 lockwasher (137).
  - (17) Place the brass gear (134) on the steer shaft (135). Replace the 3/16-inch washer (133) and the 0.122-inch retaining ring (132). Replace the 10-tooth lost motion gear (131) on the steel shaft (135). Replace the 3/16-inch steel ball (130) and the steel plate (129). Replace the assembly on the gear train assembly rear plate (146) (fig. 63) and fasten it with the 8-32 by 5/16-inch Phillips head screw (137) and the No. 8 lockwasher (128).
 

*Note:* The alignment must be precise so that this assembly will function properly.
  - (18) Assemble the gear clamp (125) and steel split gear (126). Load two teeth on the steel split gear (126) while placing it on the camshaft (171) to mesh with the steel gear and brass cam assembly (175). Tighten the 4-40 by 9/16-inch Bristo head screw (123) and the 4-40 square nut (124).
  - (19) Assemble the gear clamp (121) and steel split gear (122). Place the assembly on the camshaft (166) and tighten the 4-40 by 9/16-inch Bristo head screw (119) and the 4-40 square nut (120).
  - (20) Place the gear and cam assembly (117) on the camshaft (116); insert the No. 6/0 taper pin (118). Replace the camshaft (116), the first variable if cam (115), and the No. 6/0 taper pin (114).
  - (21) Place the steel split gear assembly (113) on the steel gear and brass cam assembly (175) and fasten it with the three 4-40 by 1/4-inch Phillips head screws (112).
  - (22) Place the gear clamp (109) on the small steel gear (111) and place the gear (111) on the steel split gear (110). Place this assembly on the camshaft (186) and tighten the 4-40 by 9/16-inch Bristo head screw (107) and the 4-40 square nut (108).
  - (23) Place the gear clamp (105) on the steel split gear (106) and place the assembly on the cam shaft (196). Tighten the 4-40 by 9/16-inch Bristo head screw (103) and the 4-40 square nut (104).
  - (24) Place the gear clamp (110) on the small steel gear (101) end place this assembly on the large steel split gear (102). Place this assembly on the camshaft (191) while loading the steel split gear (106) by two teeth. Tighten the 4-40 by 9/16-inch Bristo head screw (98) and the 4-40 square nut (99) on the gear clamp (100).
  - (25) Fasten the steel split gear (96) to the steel gear (95) with the three 4-40 by 1/4-inch Phillips head screws (97). Place the gear clamp (94) on the steel gear (95) and place the whole assembly on the camshaft (181) while loading two teeth on the steel split gear (96) and steel split gear assembly (113). Tighten the 4-40 by 9/16-inch Bristo head screw (92) and the 4-40 square nut (93).
  - (26) Replace the brass gear (91) and the 0.122-inch retaining ring (90).
  - (27) Place the gear clamp (89) on the small steel gear (86) and place them on the steel gear and shaft assembly (156). Mesh the small steel gear (86) with the brass gears (91) and (117). Tighten the 4-40 by 9/16-inch Bristo head screw (87) and the 4-40 square nut (88).
  - (28) Place the gear clamp (85) on the large

brass gear (82). Place this assembly on the steel gear and shaft assembly (156). Tighten the 4-40 by 9/16-inch Bristo head screw (83) and the 4-40 square nut (84).

- (29) Place the large brass gear assembly (81) on the camshaft (176) and fasten it with the 1/4-inch retaining ring (80).

*Note:* At this point, loosen the gear clamp (85) to make the large brass gear (82) mesh perfectly with the rear gear on the brass gear assembly (81). Tighten the gear clamp when the adjustment is completed.

- (30) Assemble the steel gear and shaft(79) by adding the aluminum separator (78), the steel gear (77), the 3/16-inch retaining ring (76), and the 3/16-inch steel washer (75). Install this assembly on the gear train assembly rear plate (146) as shown in figure 74.

- (31) Replace the pinned large brass split gear assembly (73) and the 3/16-inch washer (74) as shown in figure 63 while loading the steel split gear (122) two teeth.

*Note:* Loosen the gear clamp (121) on the steel split gear (122) to insure perfect mesh with the small gear on tile large brass split gear assembly (73).

- (32) Reassemble the differential gear assembly (61) through (72) as follows:

- (a) Be sure that the loading springs (71) are in place.
- (b) Replace the 0.395-inch retaining ring (70).
- (c) Assemble the three small gear assemblies by installing the steel loading springs (68) on the pinned brass and steel gear assembly (69); add the flat brass gears (67) and the 0.395-inch retaining rings (66).
- (d) The three similar brass split gear assemblies (65) must be placed on the pinned split gear and detent assembly (72) while loading the split gear on this assembly by two teeth.
- (e) Replace the three 0.122-inch retaining rings (64).
- (f) Place the three gears (63) so that the inner small gear meshes with the outer gear on the brass split gear assemblies (65). Load

the bottom half of the brass split gear assemblies (65) three teeth and gently rock the three gears (63) back and forth until all gears mesh.

- (g) Replace the three 4-40 by 1/4-inch Phillips head screws (61) and the three No. 4 lockwashers (62). Partially tighten each screw and check the assembly to insure proper fit before final tightening.
  - (h) Before replacing the differential gear assembly, load the steel split gear assembly (113) two teeth and hold it with a screwdriver blade; drop the differential gear in place and remove the screwdriver.
- (33) Replace the detent spring (60) and secure it with the two 6-32 by 1/4-inch Phillips head screws (58) and the two No. 6 lockwashers (59).
- (34) Replace the 5/16-inch steel washer (57) on the rf gear train front plate assembly (45). Place the pinned steel split gear assembly (56) over the washer and fasten it with the 1/8-inch retaining ring (55).
- (35) Replace the triangular steel plate (54) on the rf gear train front plate assembly (45) with the three 6-32 by 1/4-inch Phillips head screws (52) and the three No. 6 lockwashers (53).
- (36) Replace the large brass gear (51) and secure it with the 1/8-inch retaining ring (50).
- (37) Replace the pinned steel gear and shaft (49) on the front panel (45) end secure it with the 0.225-inch retaining ring (48).
- (38) Replace the rf gear train front plate assembly (45) while loading two teeth on the steel split gear assembly (56) and the large split gear (102). Replace the three 8-32 by 5/16-inch Phillips head screws (46) and the three No. 8 lockwashers (47). Loosen the gear clamp (100) on the large steel split gear (102) and adjust the gear (102) for perfect mesh on the rear gear of the steel split gear assembly (56). Tighten the gear clamp (100).
- (39) Replace the 6-40 by 6/16-inch machine screw (44).

- (40) Replace the brass gear and shaft assembly (42). When the gear and shaft assembly (42) is part way through the front plate (45), replace the 3/16-inch washer (43) and the brass gear (41). Replace the hollow pin (40) to secure the brass gear (41). Push the assembly firmly in place and secure it with the 0.207-inch retaining ring (39).
- (41) Replace the brass gear (38) and secure it with the 3/22-inch retaining ring (37). Be sure that the proper side is up for perfect mesh with the gear (42).
- (42) Replace the synchronization gear (36) with its green face up. Fasten it with the 6-32 by 3/16-inch Phillips head screw (34) and the No. 6 lockwasher (35).
- (43) Replace the two combination bevel and spur gears (32) and (33).
- (44) Replace the brass bevel gear (29) and the gear clamp (30) on the mechanical counter (25).
- (45) Replace the beveled gear (26) and the gear clamp (27) on the mechanical counter (25). Leave the gear clamps (27) and (30) loose until the mechanical counter is mounted.
- (46) Mount the mechanical counter (25) with the four 4-40 by 5/16-inch Phillips head screws (23) and the four No. 4 split lockwashers (24); tighten the 3-56 by 1/4-inch Bristo head screws (28) and (31) on the gear clamps (27) and (30). Be sure that the beveled gear (26) and the brass bevel gear (29) mesh perfectly with the gear assemblies (32) and (33) respectively.
- (47) Reassemble the clutch gear assembly as follows:
  - (a) Place the steel bushing (21) in the brass gear (12).
  - (b) Place the four clutch plates (11) in the brass gear (12) as shown in figure 63.
 

*Note.* Follow the illustration precisely.
  - (c) Replace the steel plate (10).
  - (d) Replace the two 7/16-inch flat washers (9).
  - (e) Replace the four 17/32-inch spring friction washers (8).
  - (f) Replace the 7/16-inch flat washer (7).
  - (g) Replace the pressed steel split gear assembly (6).
  - (h) Press this whole assembly together and replace the 0.395-inch retaining ring (5)
  - (i) Slip the assembly over the clutch assembly shaft (22) and secure it with the 0.225-inch retaining ring (20).
  - (j) Replace the 1/4-inch washer (19) and the flat pin (18).
  - (k) Replace the stop spring (17), spring holder (16), and the stop washer (15). Secure it in place with the 0.225-inch retaining ring (14).
  - (l) Replace the zero adjust shaft (13).
  - (m) Place the 5/16-inch lockwasher (2) and the 5/16-24 hexagonal nut (1) on the clutch assembly shaft (22).
  - (n) Mount the clutch gear assembly on the rf gear train assembly while loading two teeth on the steel split gear assembly (6) to mesh with the spur gear part of the gear assembly (33). Tighten the 5/16-24 hexagonal nut (1) and replace the 6-32 by 5/16-inch Phillips head screw (3) and No. 6 lockwasher (4).
- (48) Replace the 8 slug racks and the 16 tension springs.
- (49) Synchronize the Geneva system and over travel coupler as follows:
  - (a) Rotate the rear portion of the three gears (63) to the extreme clockwise position.
  - (b) Loosen the gear clamp (85).
  - (c) Keep rotating the rear portion of the gear (63) past the extreme clockwise position to a point midway between detent positions.
 

*Note:* The position should be checked visually on the detent assembly (72).
  - (d) Tighten the gear clamp (85).
  - (e) Rotate the rear portion of the gear (63) counterclockwise to the first detent position.
  - (f) Loosen the gear clamp (27) and

- (30) and adjust the mechanical counter to read 00 000; then tighten the gear clamps.
- (50) With the mechanical counter indicating 00 000, set the rf band switch (S201 through S210) to the position shown in figure 76. Use S206 (fig. 22) as viewed from the rear for the rf band switch setting by loosening the gear clamp (150) and turning the rf band switch shaft (151) with a pair of long-nosed pliers. Tighten the gear clamp when the adjustment is completed.
- (a) Rf band switch section S206 should be on contact 7 as shown in figure 76. Rotate the reapportion of the gear (63) in a counterclockwise direction to read 01 000 on the frequency indicator. Rf band switch section S206 should be on contact 6. Move the rear portion of the gear (63) counterclockwise to read 02 000 on the frequency indicator. Rf band switch section S206 should be on contact 5. Following this same procedure for the remainder of the positions on the frequency indicator, S206 should be on contact 5 for 03 000; the other arm of the switch should be on contact 3 for 04 000,

05 000, 06 000, 07 000; contact 2 for 08 000, 09 000, 10 000, 11 000, 12 000, 13 000, 14 000, and 15 000; and finally come to rest on contact 1 for 16 000 through 31 000.

- (b) If the rf band switch does not track as shown in (a) above, repeat the procedure in (49) above and try a new setting before or beyond the midway point between the two detent positions.
- (51) Rotate the rear gear of the gear assembly (63) in a counterclockwise direction until the mechanical counter reads 02 000.
- (52) Synchronize the rf gear train according to the instructions in paragraph 73. Since the rf subchassis is removed from the receiver, move the rear gear of the gear assembly (63) in a counterclockwise direction when it is desired to go to a higher channel.
- (53) Replace the rf subchassis (para 59 b).
- (54) Replace the front panel (para 58 b).
- (55) Synchronize crystal-oscillator band switch and vfo tuning shaft (para 73).
- (56) Align and adjust the receiver, if necessary (para 76).

c. *Gear Train Legend.*

Index No.	Reference symbol	Description
1		5/16-24 hex. nut.
2		5/16-inch lockwasher.
3		6-32 by 5/16-inch Phillips head screw.
4		No. 6 lockwasher.
5	H252	0.395-inch inside diameter by 0.025 thick retaining ring.
6	O339	Steel split gear assembly, 2-1/4-inch diameter, 108 teeth.
7		7/16-inch flat washer.
8		17/32-inch spring friction washer.
9		7/16-inch flat washer.
10		Steel plate, part of clutch assembly.
11		Clutch plates.
12	O338	Brass gear, 2-1/2-inch diameter, 72 teeth.
13		Zero adjust shaft.
14	H516	Retaining ring, 0.225-inch diameter.
15		Stop washer.
16		Spring holder.
17		Stop spring for zero adjust knob.
18		Flat pin.
19		1/4-inch washer.
20	H516	Retaining ring 0.225-inch diameter.
21		Steel bushing.
22		Clutch assembly shaft.
23		4-40 by 5/16-inch Phillips head screw.
24		No. 4 split lockwashers.

Index No.	Reference symbol	Description
25	M201	Mechanical counter.
26	O334	Beveled gear, 3/4-inch diameter, 48 teeth.
27		Gear clamp.
28		3-56 by 1/4-inch Bristo head screw.
29	O335	Brass bevel gear, 7/16-inch diameter, 24 teeth.
30		Gear clamp.
31		3-56 by 1/4-inch Bristo head screw.
32	O341	Gear assembly. front gear beveled, 24 teeth, rear 50 teeth.
33	O333	Gear assembly. front gear beveled 48 teeth; rear 27 teeth.
34		6-32 by 3/16-inch Phillips head screw.
35		No. 6 lockwasher.
36	O330	Green-faced gear, 1-1/2-inch diameter, 70 teeth.
37	H222	0.207-inch retaining ring.
38	O322	Brass gear, 1-inch diameter, 64 teeth.
39	H222	0.207-inch retaining ring.
40		Hollow pin.
41		Brass gear, 15/16-inch diameter, 32 teeth.
42		Brass gear and shaft assembly (gear 1/2-inch diameter, .32 teeth).
43		3/16-inch washer.
44		6-40 by 5/16-inch machine screw.
45		Rf gear train front plate assembly.
46		8-32 by 5/16-inch Phillips head screw.
47		No. 6 lockwasher.
48	H516	Retaining ring 0.225-inch diameter.
49	O301	Steel gear, 9/16-inch diameter on 1-3/4-inch long shaft, 17 teeth.
50	H716	0.122-inch retaining ring.
51	O323	Brass gear, 3-1/8-inch diameter, 100 teeth.
52		6-32 by 1/4-inch Phillips head screw.
53		No. 6 lockwasher.
54		Triangular steel plate with bushing.
55	H716	0.122-inch retaining ring.
56	O324 O325	Steel split gear assembly 68 teeth, with pinned brass gear, 40 teeth.
57		5/16-inch steel washer.
58		6-32 by 1/4-inch Phillips head screw.
59		No. 6 lockwasher.
60		Detent spring.
61		4-40 by 1/4-inch Phillips head screw.
62		No. 4 lockwasher.
63		Three gears, consisting of front steel gear, 3-1/4-inch diameter, 102 teeth; rear brass gear, 3-1/8-inch diameter, 100 teeth, small steel gear, 5/8-inch diameter, 28 teeth.
64	H716	0.122-inch retaining ring.
65		Brass split gear assembly with small steel gear, 1-1/4-inch diameter; split gears with 56 teeth each. and small gear with 21 teeth.
66	H232	0.395-inch retaining ring.
67	O279	Brass gear, 1-3/16-inch diameter, 56 teeth.
68		Steel loading spring.
69	O279	Pinned brass and steel gear assembly; brass gear 1-3/16-inch diameter, 56 teeth; and steel gear, 1/2-inch diameter, 21 teeth.
70	H252	0.395-inch retaining ring.
71		Loading spring.
72	O282	Split gear and detent assembly, small brass split gear 1-3/8-inch diameter, 63 teeth, brass or steel detent 2-3/8-inch diameter with large steel rear gear, 2-1/8-inch diameter, 63 teeth.
73	O296	Large brass split gear assembly, 2-3/4-inch diameter, 85 teeth with small steel gear, 25 teeth.
74		3/16-inch washer.
75		3/16-inch steel washer.
76		3/16-inch retaining ring.
77		Steel gear, 2-9/16-inch diameter, 80 teeth.
78		Aluminum separator, 2-inch diameter, 3/32-inch thick.
79		Steel gear, 2-9/16-inch diameter, 80 teeth, 1-3/4-inch long shaft.
80	H234	0.281-inch retaining ring.
81	O268	Brass gear assembly. 3-1/8-inch diameter, 100 teeth, smaller gear 2-3/8-inch diameter, 75 teeth.
82	O300	Large brass gear, 2-9/16-inch, 80 teeth.
83		4-40 by 9/16-inch Bristo head screw.

Index No.	Reference symbol	Description
84		4-40 square nut.
85		Gear clamp.
86	O229	Small steel gear, 15/16-inch diameter, 32 teeth.
87		4-40 by 9/16-inch Bristo head screw.
88		4-40 square nut.
89		Gear clamp.
90	H716	0.122-inch retaining ring.
91	O266	Brass gear, 1-1/2-inch diameter. 53 teeth.
92		4-40 by 9/16-inch Bristo head screw.
93		4-40 square nut.
94		Gear clamp.
'15	O273	Steel gear, 1-3/16-inch diameter. 54 teeth.
96		Steel split gears, 2-5/16-inch diameter, 108 teeth.
97		4-40 by 1/4-inch Phillips head screw.
98		4-40 by 9/16-inch Bristo head screw.
99		4-40 square nut.
100		Gear clamp.
101	O261	Small steel gear, 1-3/16-inch diameter, 54 teeth.
102	O277	Large steel split gear, 2-5/16-inch diameter, 72 teeth.
	O278	
103		4-40 by 9/16-teeth Bristo head screw.
104		4-40 square nut.
105		Gear clamp.
106	O262	Steel split gear, 2-9/32-inch diameter, 108 teeth.
	O263	
107		4-40 by 9/16-inch Bristo head screw.
108		4-40 square nut.
109		Gear clamp.
110		Steel split gear, 1-11/16-inch diameter, 54 teeth.
111	O261	Small steel gear, 1-3/16-inch diameter, 54 teeth.
112		4-40 by i/4-inch Phillips head screw.
113	O289	Steel split gear assembly, 2-9/32-inch diameter, 108 teeth.
114		No. 6/0 taper pin.
115		1st variable if. cam, rear.
116		Camshaft.
117	O267	Brass gear, fixed to 1st variable if. cam, front, 2-9/16-inch diameter, 90 teeth.
118		No. 6/0 taper pin.
119		4-40 by 9/16-inch Bristo head screw.
120		4-40 square nut.
121		Gear clamp.
122	O275	Steel split gear, 2-5/16-inch diameter, 72 teeth.
123		4-40 by 9/16-inch Bristo head screw.
124		4-40 square nut.
125		Gear clamp.
126	O264	Steel split gear, 2-5/16-inch diameter, 108 teeth.
127	O265	8-32 by 5/16-inch Phillips head screw.
128		No. 8 lockwasher.
129		Steel plate.
130		3/16-inch steel ball.
131	O312	Lost motion gear, 10 teeth.
132	H716	0.122-inch retaining ring.
133		3/16-inch washer.
134	O313	Brass gear, 1-15/16 diameter, 90 teeth.
135		Steel shaft.
136		6-32 hexagonal nut.
137		No. 6 lockwasher.
138		3/32-inch retaining ring.
139	O309	Small steel gear combination 8 teeth and 4 teeth, 7/16-inch diameter.
140		Steel shaft, 6-32 thread on one end.
141		6-32 by 5/16-inch hexagonal head screw.
142		No. 6 lockwasher.
143	11716	0.122-inch retaining ring.
144	O307	Brass gear, 15/16-inch diameter, 21 teeth.
145		Steel shaft.
146		Gear train assembly rear plate.
147	H731	0.225-inch retaining ring.
148		4-40 by 5/16-inch Bristo head screw.

Index No.	Reference symbol	Description	
149	O303	4-40 square nut.	
150		Gear clamp.	
151		Rf band switch shaft.	
152		1-1/16-inch diameter steel gear, 24 teeth.	
153		6-32 by 3/16-inch Phillips head screw.	
154		No. 6 lockwasher.	
155		Flange for crystal switch shaft.	
156		Steel gear and shaft assembly, 3/8-inch diameter, 16 teeth.	
157		Hollow pin.	
158		Oldham coupler.	
159		3/16-inch steel washer.	
160		No. 6/0 taper pin.	
161		2d variable if. cam, front.	
162		No. 6/0 taper pin.	
163		2d variable if. cam, inside.	
164		No. 6/0 taper pin.	
165		2d variable if. cam, inside.	
166		Camshaft.	
167		No. 6/0 taper pin.	
168		2d variable if. cam, rear.	
169		No. 6/0 taper pin.	
170		16-to 32-mc rf cam, front.	
171		Camshaft.	
172		No. 6/0 taper pin.	
173		16-to 32-mc rf cam, rear.	
174		No. 6/0 taper pin.	
175		O359	Steel gear and brass cam assembly; 8 to 16 me, front; gear in 1-1/4-inch diameter, 54 teeth.
176			Camshaft.
177			No. 6/0 taper pin.
178			8-to 16-mc rf cam, rear.
179			No. 6/0 taper pin.
180			4-to 8-mc rf cam, front.
181			Camshaft.
182			No. 6/0 taper pin.
183			4-to 8-mc rf cam, rear.
184	No. 6/0 taper pin.		
185	2-to 4-mc rf cam, front.		
186	Camshaft.		
187	No. 6/0 taper pin.		
188	2-to 4-mc rf cam, rear.		
189	No. 6/0 taper pin.		
190	0.5- to 1-mc rf cam, front.		
191	Camshaft.		
192	No. 6/0 taper pin.		
193	0.5- to 1-me rf cam, rear.		
194	No. 6/0 taper pin.		
195	1-to 2-mc rf cam, front.		
196	Camshaft.		
197	No. 6/0 taper pin.		
198	1-to 2-mc rf Cam, rear.		
199	8-32 by 3/32-inch Bristo head set screw.		
200	1/4-inch coupler.		
201	1/4-inch fiber shaft.		
202	3/8-32 hexagonal head nut.		
203	3/8-inch lockwasher.		
204	3/8-inch flat washer.		
205	3/8-inch insulated washer.		
206	6-32 by 3/8-inch Phillips head screw.		
207	No. 6 lockwasher.		
208	L-brackets.		
209	Bracing rods.		
210	8-32 by 3/8-inch hexagonal head screw.		
211	No. 8 lockwasher.		
212	8-32 by 1/4-inch flathead Phillips head screw.		
213	Separator rod, 1-13/32 inches long by 5/16-inch wide.		
214	8-32 by 3/8-inch hexagonal head screw.		

Index No.	Reference symbol	Description
215		No. 8 lockwasher.
216		8-32 by 1/4-inch flathead Phillips head screw.
217		No. 8 lockwasher.
218		Rf subchassis rear plate.

### 73. Mechanical and Electrical Synchronization (fig. 43 and 44)

The receiver tuning shafts, consisting of the six-position rf band switch shaft, slug rack, camshafts, crystal-oscillator band switch shaft, and the vfo tuning shaft, must be in synchronization with the gear train before the receiver is aligned. To synchronize the receiver tuning system, follow the procedures given *ina* through *d* below.

*a. Camshafts.* The camshafts are synchronized properly if the index lines etched on the rear plate of the rf subchassis bisect the holes in each of the rear cams (fig. 44) when the frequency-indicator reading is 02 000. To synchronize the rf subchassis when it is removed from the cabinet, rotate the large brass split gear and the clutch gear (fig. 43) to positions where the frequency-indicator reading is 02 000. If the index lines do not bisect the holes, follow the procedure out-lined in (2) through (7) below. Before replacing the rf subchassis (para 5*b* above to positions where), rotate the two gears mentioned above to positions where the first two digits on the frequency indicator indicate halfway between 99 and 00, and the last three digits read -972. (Note the minus sign.) When the rf subchassis is in the cabinet, proceed as follows:

*Note:* The camshafts are secured to the drive gears by clamps at the hubs of the gears. To position a camshaft, loosen the clamp which (except for the 8-to 16-mc shaft) is located at the end of the individual shaft in front of the rf subchassis. To avoid losing the nut, do not loosen the clamp more than necessary. Be careful not to strip the screw thread.

- (1) Check the 10-turn stop by rotating the MEGACYCLE CHANGE and the KILOCYCLE CHANGE controls fully counterclockwise. The frequency indicator should read halfway between 99 and 00 (off detent position) and -972. (Note the minus sign.) Check the reading on the megacycle

portion of the frequency indicator. If it does not agree, loosen the crystal-oscillator band switch position indicator to see that it agrees with the reading on the Oldham coupler clamp (fig.41) on the crystal oscillator and turn the SYNC XTAL OSC control on the rear panel (TM 11-5820-357-10) until the two readings agree. Tighten the clamp on the Oldham coupler. Check the synchronization of each band by noting the position of the cam rollers at the end frequencies of each band. The position of the 1- to 2-mc band cam shown in figure 44 represents the correct position for the low end of the band. ~~The position of the second rf. cam shown in figure 44 represents the correct position for the high end of the band (the last three digits of the frequency indicator should read 999).~~ If all the cams are out of synchronization, set the 8- to 16-mc cam first.

- (2) If the 1- to 2-mc camshaft (fig. 44) is not positioned properly, loosen the clamp on the front of the shaft and rotate the rear cam until the index line bisects the hole in the cam. Tighten the clamp.
- (3) Position the camshaft for .5- to 1-mc slug rack (fig. 44), if necessary, in the same manner as described in (2) above.
- (4) Check the position of the 8-to 16-mc camshaft. If it is not aligned properly, loosen the clamp on the front of the 2- to 4-mc shaft to position the 8- to 16- mc cam, since the gear for the 8- to 16-mc shaft is pinned through the shaft. After positioning the 8-to 16-mc cam, position the 2- to 4-mc cam while holding the 8- to 16-mc cam in place; then tighten the clamp on the 2- to 4-mc shaft.

- (5) necessary, position the 4- to 8-mc and 16- to 32-mc cams (fig. 44) in the same manner as described in (2) above.
- (6) To position the first variable if. cam (fig. 44), loosen the clamp nearest the front plate of the rf subchassis on the crystal-oscillator band switch shaft. Adjust the position of the cam; then tighten the clamp.
- (7) Position second variable if. cam (fig. 44), if necessary, in the same manner as for the 1- to 2-, .5- to 1-, 4- to 8-, and 16- to 32-mc cams.
- (8) Check the reading of the frequency indicator. If a reading of 02 is not centered within the two left-hand spaces of the indicator, loosen the clamp on the bevel gear on the shaft extending from the left side of the indicator (fig. 43). Set the two number wheels for a reading of 02, and retighten the bevel-gear clamp.
- (9) If a reading of 000 does not appear in the last three spaces of the frequency-indicator dial, loosen the clamp securing the bevel gear on the shaft extending from the right side of the indicator. Set the three number wheels for a reading of 000.

*b. Six-Position Rf Band Switch.* The procedure for checking and synchronizing the rf band switch is as follows:

- (1) Turn the MEGACYCLES control through its range. The rf band switch should move between 0 and 1, and 2, 3 and 4, 7 and 8, and 15 and 16 mc. If the rf band switch does not move between the bands indicated, synchronization of the rf band switch ((2), (3), and (4) below) is necessary.
- (2) Rotate the MEGACYCLE CHANGE control fully counterclockwise, and then turn the control clockwise through the two detent positions to the third detent position.
- (3) Remove the rf subchassis (para 59).
- (4) Loosen the clamp on the front of the six-position rf band switch shaft located on the bottom of the rf subchassis. Rotate the shaft until the switch

contacts are centered at position 3 by inserting long-nosed pliers in the hole at the rear of the subchassis (fig. 44) and turning the shaft. Positions of the switch contacts are shown in the schematic diagram (fig. 74). Tighten the clamp after adjustment.

*c. Crystal-Oscillator Band Switch.* Check and synchronize the crystal oscillator as follows:

- (1) The rotor of the crystal-oscillator band switch is positioned correctly when the number centered in the slot of the crystal-oscillator band switch position indicator (fig. 23) agrees with the reading of the megacycle portion (first two digits) of the frequency indicator.
- (2) If the indication is incorrect, loosen the clamp on the flange of the Oldham coupler (fig. 41) and rotate the SYNC XTAL OSC control to center the proper reading in the slot.

*d. Vfo Tuning Shaft.* Synchronize the vfo tuning shaft as follows:

- (1) Turn on the receiver and allow sufficient time for it to warm up.
- (2) Fabricate cable No. 1 (fig. 69), excluding RF Plug UG-88/U.
- (3) Disconnect plug P723 from jack J223 on the rf subchassis and connect P723 to RF jack UG-89/U on fabricated cable (fig. 28).
- (4) Insert the center conductor on the other end of cable into UNBALANCED ANTENNA WHIP input receptacle J107 of a second Radio Receiver R-390/URR (called a test receiver in this procedure).
- (5) Turn the BFO switch on the receiver to ON, and tune the test receiver between 2.2 and 3.7 mc (this represents the frequency range of the vfo) until a signal is heard. Note the frequency on the test receiver.
- (6) Loosen the clamp on the side of the Oldham coupler that is closest to the front panel to enable the vfo tuning shaft to turn freely (fig. 42).
- (7) Tune a signal the receiver to 2.955mc.
- (8) Turn the shaft of the vfo until a signal is heard.

*Caution:* The vfo will be permanently damaged if the shaft is turned too far in either direction.

*Note:* The vfo frequency is decreased with a clockwise rotation of the vfo shaft as viewed from the front panel.

- (9) Reconnect plug P723 into J223 on the rf subchassis of the receiver (fig. 42). Set the FUNCTION switch to CAL and the BFO switch to ON. Connect a headset into the PHONES jack.
- (10) With the first two digits of the frequency indicator at any setting, set the KILOCYCLE CHANGE control to 500
- (11) Tighten the clamp on the side of the Oldham coupler.

- (12) The receiver should be checked against a station of known frequency accuracy such as WWV.

#### 74. Hum Balance Adjustment

(fig. 32)

Adjust the regulated voltage for minimum hum as follows:

a. Make sure the receiver is grounded.

b. Connect the ME-6/U between B+ 180 V DC jack J601 and ground and set it on the 0.01- to 0.1-ac range.

*Warning:* Avoid contact with the B+ V DC jack when the receiver is turned on; 180 volts dc is present at this jack.

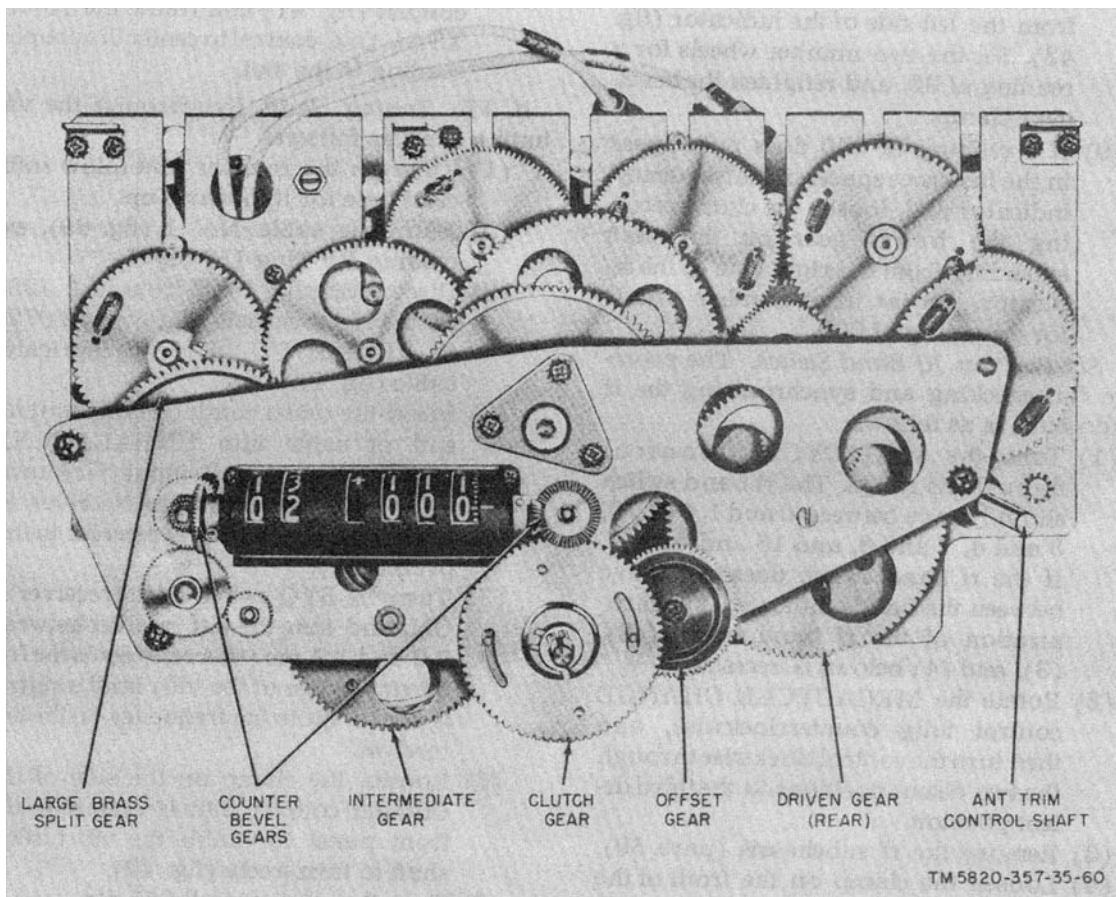

Figure 43. Location of gears.

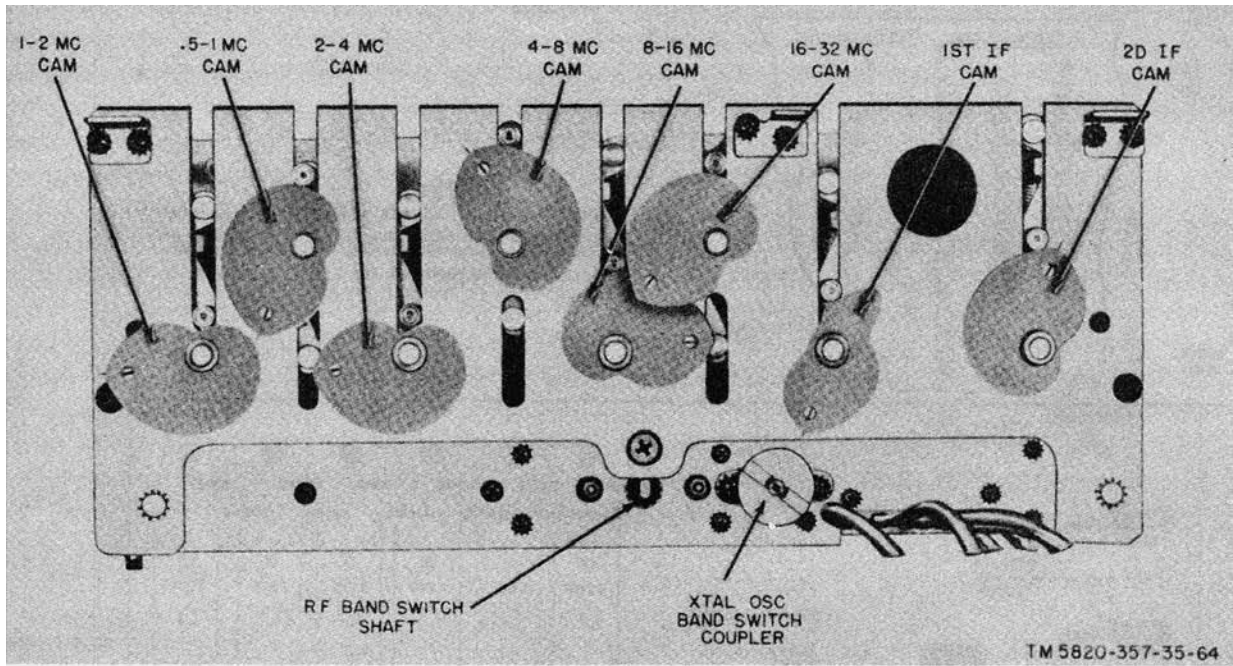

Figure 44. Location of cams.

- c. Check to see that switch S801 on Power Supply PP-621/URR is set to 115 VAC.
- d. Connect the receiver to a power source that is exactly 115 volts ac and allow it to warm up.

- e. Insert a screwdriver in the slot of HUM BAL control R614 (fig. 32), accessible through the right side plate of the main frame, and adjust for minimum indication on the ME-6/U.

## Section II. ALIGNMENT

### 75. Test Equipment and Special Tool Required for Alignment

The following test equipment and special tool required for alignment of Radio Receiver R-390/URR

Item	Technical manual
Electronic Multimeter TS-505(*)/U <sup>a</sup>	TM 11-5511 and TM 11-6625-239-12
Rf Signal Generator AN/URM-25(*) <sup>b</sup> .	TM 11-5551D or TM 11-5551E
Voltmeter, Meter ME-30(*)/U <sup>c</sup> Alignment tool (insulated)-----	TM 11-6625-320-12

<sup>a</sup> Indicates TS-505/U and TS-505A/U through TS-505D/U.

<sup>b</sup> Indicates AN/URM-25D or AN/URM-25F,

<sup>c</sup> Indicates ME-30A/U and ME-30B/U.

### 76. Alignment of 455-Kc If. Stages (fig. 45)

- a. Turn on the AN/URM-25(\*) and receiver and allow them to warm up for 30 minutes.
- b. Make the following control settings on the receiver:
  - (1) BANDWIDTH to .1.
  - (2) RF GAIN to 10.
  - (3) BFO to OFF.
  - (4) FUNCTION to MGC.
- c. Connect the TS-505/U to DIODE LOAD terminal 14 of the rear terminal strip of the receiver (TM 11-5820-357-10). Adjust the TS-505/U to measure negative voltage.
- d. Adjust the AN/URM-25(\*) for an unmodulated 455-kc output. Connect the output

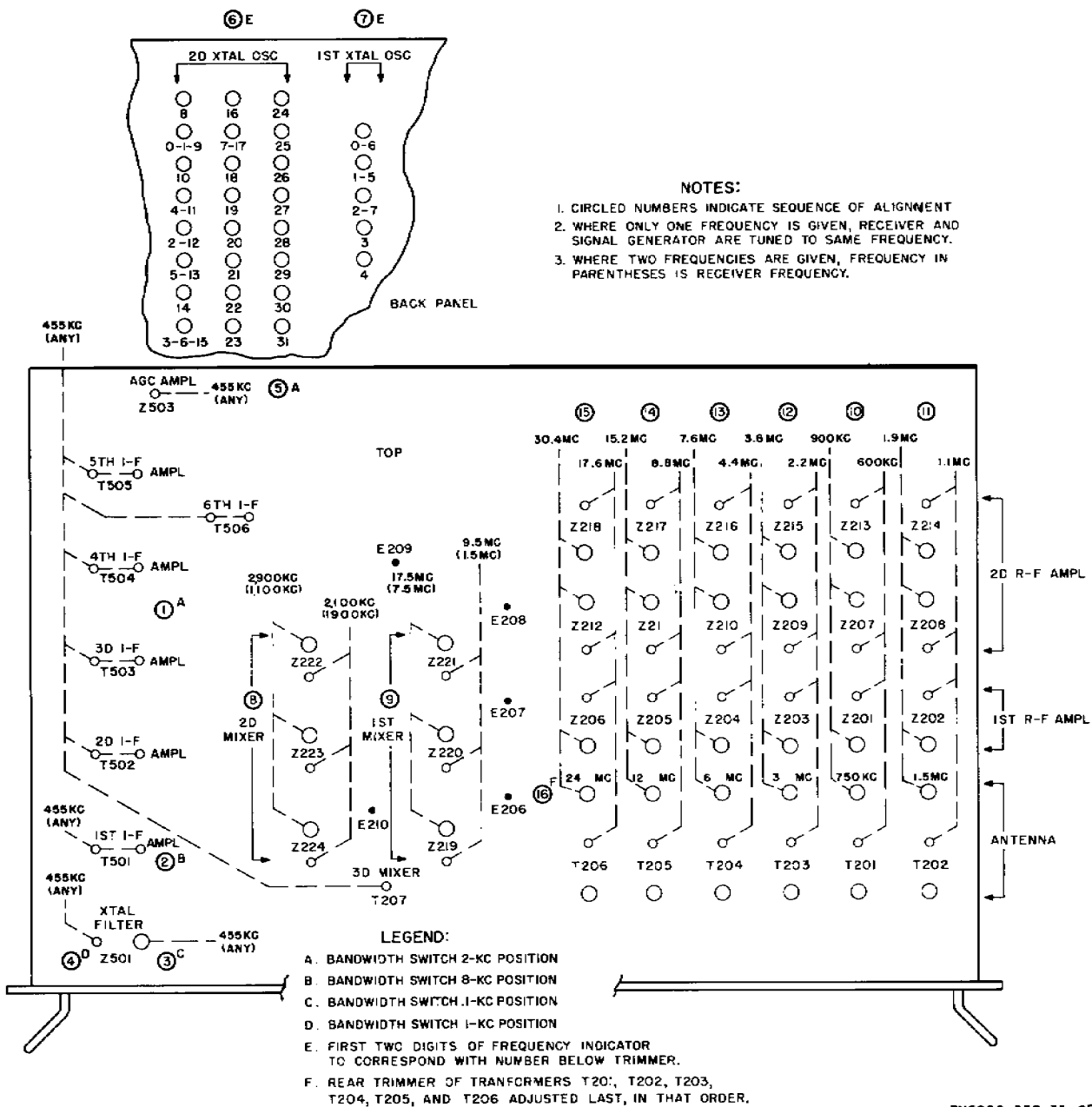

Figure 45. Alignment points.

of the AN/URM-25(\*) to test point E210 and chassis ground.

e. Adjust the frequency control of the AN/URM-25(\*) to obtain a peak indication on the TS-505(\*)/U. It may be necessary to set the attenuation of the AN/URM-25(\*) for high amplitude output signal. If an indication on the TS-505(\*)/U is obtained, perform the procedure given in f

below. If no reading is obtained, perform the procedure outlined in (1) and, if necessary (2) below, to secure approximate alignment before performing the procedure given in f below.

- (1) Set the AN/URM-25(\*) frequency to 455 kc; set the attenuator for full out put. Turn the receiver BANDWIDTH

switch to 16. If the output indication is not obtained, proceed with the procedure given in (2) below. If an indication is obtained, adjust the cores of transformers T506 through T501 and T207, in that order, for peak indication on the TS-505(\*)/U. Set the BANDWIDTH switch at the next lower position, and repeat the adjustment of the transformer cores for maximum output. Repeat this procedure for each setting of the BANDWIDTH switch until peak output is obtained at the .1 position of the switch. Perform the procedure given in *f* below.

*Note:* The frequency will decrease as the slugs are screwed farther into the coils, and will increase as the slugs are withdrawn.

- (2) Perform the procedure outlined in (a) and (b) below only when the transformer cores have been displaced greatly from their normal positions within the coils.
- (a) Set the BANDWIDTH switch to 2. Adjust the attenuator for maximum output. Remove sixth if. amplifier tube V506 and wrap a thin wire lead around pin 1 (grid). Replace the tube, and connect the other end of the lead to the AN/URM-25(\*) output.
- (b) Adjust the cores of transformer T506 for peak indication on the TS-505(\*)/U.
- (c) Apply the AN/URM-25(\*) output to fifth if. amplifier V505, as described in (a) above for V506, and adjust the cores of transformer T505 for maximum indication on the TS-505(\*)/U.
- (d) Repeat the above procedure for each remaining set of if tubes and transformers in the following order: V504 and T504, V503 and T503, V502 and T502, V501 and T501, and V205 and T207.
- f.* Set the BANDWIDTH switch to .1. Adjust the attenuator of the AN/URM-25(\*) to maintain an indication of approximately 6 volts on the TS-505(\*)/U. Carefully adjust the AN/URM-25(\*) frequency for a peak output indication on the TS-505(\*)/U. Do not change

this frequency setting while carrying out the procedures outlined in *g*, *h*, and *i* below.

- g.* Set the BANDWIDTH switch to 2.
- h.* Adjust the cores of transformers T506, T505, T504, T503, T502, and T207, in that order, for a peak indication on the TS-505(\*)/U, while adjusting the attenuator of the AN/ URM-25(\*) to maintain an indication of approximately 6 volts on the TS-505(\*)/U. Repeat these adjustments until no further increase is noticed.
- i.* Set the BANDWIDTH switch to 8, and adjust the cores of transformer T501 for a maximum indication. Repeat the adjustment of the cores until no further increase in output can be produced.
- j.* Set the BANDWIDTH switch to .1
- k.* Adjust the attenuator of the AN/URM-25(\*) for an indication of approximately 6 volts on the TS-505(\*)/U. Note the AN/URM-25(\*) attenuator setting. Tune the AN/URM-25(\*) frequency away from the frequency required for peak reading; at the same time, increase the output of the AN/URM-25(\*) to restore the TS-505(\*)/U indication to its original value. Continue changing the AN/URM-25(\*) frequency in this direction until the voltage output required to obtain the original indication on the TS-505(\*)/U is 1,000 times the voltage required at peak frequency.
- l.* Adjust the phasing capacitor in crystal filter Z501 for a minimum TS-505(\*)/U indication, and note the position of the capacitor slot.
- m.* Tune the AN/URM-25(\*) frequency to the opposite side of the frequency required for peak output, and set the attenuator for increased output (*k* above).
- n.* Adjust the phasing capacitor in Z501 for minimum indication, and note the position of the capacitor; then, set the capacitor approximately half way between the two noted settings. To avoid possible incorrect readings, caused by tuning through the positions of minimum or maximum capacitance, the two capacitor settings for minimum output must be less than 45° apart.
- o.* With the BANDWIDTH switch at .1, tune the AN/URM-25(\*) frequency to obtain peak output. Set the BANDWIDTH switch to 1

Adjust the core of the tuning coil in crystal filter Z501 until the AN/URM-25 frequency required for obtaining peak output, with the BANDWIDTH KC switch at .1, corresponds exactly to the frequency required for peak output in the 1 position. Retune the AN/URM-25(\*), and alternately change positions of the BANDWIDTH switch as required to complete this adjustment.

*p.* Set the BANDWIDTH switch to .1, and tune the AN/URM-25(\*) for maximum output as described in *f* above. Do not disturb this frequency setting during the adjustment of the agc tuning circuit in the following steps.

*q.* Disconnect the TS-505(\*)/U lead from terminal 14 of the rear terminal strip, and connect it to terminal 4 of the rear terminal strip (TM 11-5820-357-10).

*r.* Set the FUNCTION switch to AGC, and the BANDWIDTH switch to 2.

*s.* Adjust the core of Z503 for a maximum indication on the TS-505(\*)/U, while adjusting the AN/URM-25(\*) attenuator to maintain a peak indication of approximately 2 volts. Vixen the adjustment is completed, disconnect the TS-505(\*)/U.

## 77. Alignment of Second Crystal Oscillator (fig. 23, 45, and 46)

*a.* Adjust the TS-505(\*)/U to measure negative dc volts and connect it between test point E209 (fig. 45) (grid of second mixer V204) and ground.

*b.* Turn the OVENS switch to ON and the FUNCTION switch to STAND BY. Allow the receiver to warm up.

*c.* Set the MEGACYCLE CHANGE control so that the frequency indicator reads 31.

*d.* Remove the plate on the rear panel of toe receiver.

*e.* Screw the slug of T402 (fig. 23) out until only one peak reading on the TS-505(\*)/U can be obtained, while turning trimmer capacitor 31 (fig. 45 and 46) throughout its entire range.

*f.* Set the trimmer capacitor slightly away from the position of peak reading, and adjust the slug of T402 for peak reading, adjust the slug of T402 for peak indication on the TS-505(\*)/U.

*g.* Adjust the second crystal-oscillator trimmers (large group of trimmers on rear panel (fig. 46)), using the chart below. Set the MEGACYCLE CHANGE control for a megacycle reading on the frequency indicator shown in the first column, and adjust the trimmer designated in the second column for the meter indication shown in the last column. Where a trimmer is used in the crystal-oscillator circuit at more than one frequency setting of the MEGACYCLE CHANGE control, it is listed only for the first setting and is adjusted for maximum only at this setting. For subsequent frequency setting of the MEGACYCLE CHANGE control involving a previously adjusted trimmer, check only for an indication on the TS-505(\*)/U. If no indication is obtained, check the crystal-oscillator bandswitch.

Dial reading	Adjust trimmer	Meter indication
31	31	Maximum.
30	30	Maximum.
29	29	Maximum.
28	28	Maximum.
27	27	Maximum.
26	26	Maximum.
25	25	Maximum.
24	24	Maximum.
23	23	Maximum.
22	22	Maximum.
21	21	Maximum.
20	20	Maximum.
19	19	Maximum.
18	18	Maximum.
16	7, 17	Maximum.
15	3, 6 15	Maximum.
14	14	Maximum.
13	5, 13	Maximum.
12	2, 12	Maximum.
11	4, 11	Maximum.
10	10	Maximum.
09	0, 1, 9	Maximum.
08	8	Maximum.
07		Check for indication.
06		Check for indication.
05		Check for indication.
04		Check for indication.
02		Check for indication.
01		Check for indication.
00		Check for indication.

## 78. Alignment of First Crystal Oscillator (fig. 20, 23, 45, and 46)

*a.* Adjust the TS-505(\*)/U to measure negative dc volts, and connect it between

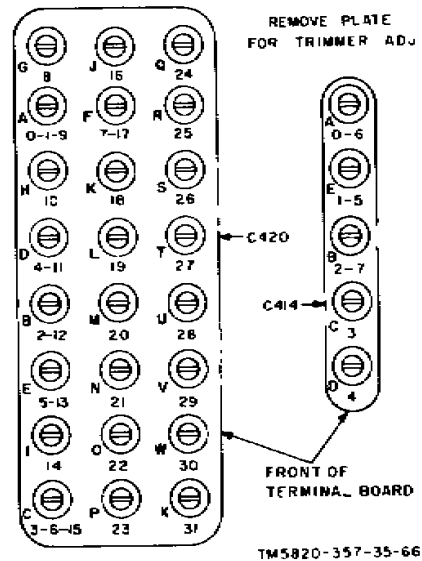
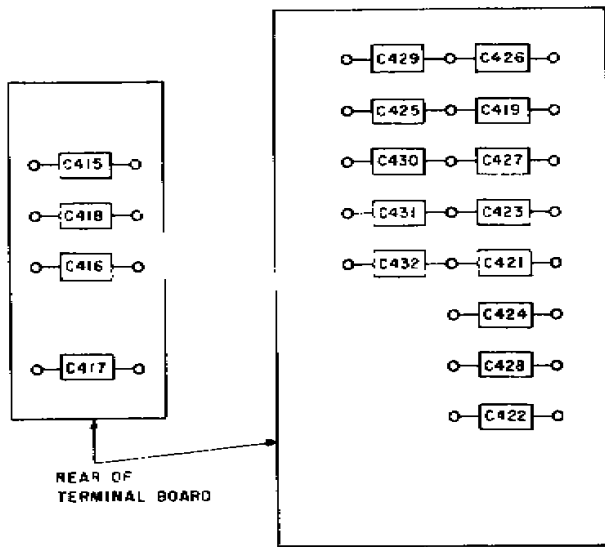

Figure 46. Location of crystal oscillator tuning capacitors

test point E208 (fig. 20) (grid of first mixer V203) and ground.

b. Turn the OVENS switch to ON and the FUNCTION switch to STAND BY. Allow the receiver to warm up.

c. Set the MEGACYCLE CHANGE control so that the megacycle reading on the frequency indicator is 03.

d. Adjust the slug of T401 (fig. 23) for peak indication on the TS-505(\*)/U.

e. Adjust the first crystal-oscillator trimmers (group of five trimmers on the rear panel (fig. 46)), using the chart below in the manner described in paragraph 77.

Dial reading	Adjust trimmer	Meter indication
07	2,7	Maximum.
06	0,6	Maximum.
05	1,5	Maximum.
04	4	Maximum.
03	3	Maximum.
02	No adjustment	Check for indication.
01	No adjustment	Check for indication.
00	No adjustment	Check for indication.

### 79. Alignment of Second Variable If. Stage (fig 45)

a. Adjust the TS-505(\*)/U to measure a negative do voltage of approximately 5 volts. Connect the TS-505(\*)/U ground lead to the receiver chassis, and the do input lead to DIODE LOAD terminal 14 of the rear terminal strip (TM 11-5820-357-10).

b. Connect the output of the AN/URM-25(\*) to test point E209 (fig. 20) (control grid of second mixer V204).

Connect the ground lead of the AN/U11M-25(\*) to the receiver chassis.

c. Set the receiver FUNCTION switch to AGC, and the RF GAIN control to 10.

d. Set the MEGACYCLE CHANGE and KILOCYCLE CHANGE controls for a frequency-indicator reading of 01 900.

e. Connect the headset to the PHONES jack. Modulate the AN/URM-25(\*) 30 percent with 400 cycles, and tune it to approximately 2,100 kc to obtain an audible receiver output. Tune the AN/URM-25(\*) to the exact frequency which produces a peak indication on the TS-505(\*)/U. Continuously change the attenuator setting of the AN/URM-25(\*) to maintain a reading of less than 5 volts on the TS-505(\*)/U.

f. Adjust the slugs of tuned circuits Z222, Z223, and Z224 for a peak indication on are The TS-505(\*)/U. The three slugs mounted on the second variable if. slug rack.

g. Tune the receiver to 1,100 kc, using the KILOCYCLE CHANGE control.

h. Tune the AN/URM-25(\*) to 2,900 kc, and then set it to the exact frequency which produces a peak indication on the TS-506(\*)/U.

i. Adjust the three trimmers mounted within the shield cans of tuned circuits Z222, Z223, and Z224 for peek output.

j. Repeat the procedure given ine through

*i* above until no increase in output can be obtained. Set the AN/URM-25(\*) attenuator so that the indication on the TS-505(\*)/U is less than 5 volts, while making all adjustments.

## 80. Alignment of First Variable If. Stage

(fig. 64)

*a.* Connect the AN/URM-25(\*) output to test point E208 (fig. 20) (control grid of first mixer tube V203). Connect the TS-505(\*)/U ground lead to the receiver chassis, and the dc test load to DIODE LOAD terminal 14 of the rear terminal strip (TM 11-5820-357-10).

*b.* Set the MEGACYCLE CHANGE and KILOCYCLE CHANGE controls for a frequency-indicator reading of 01 500.

*c.* Tune the AN/URM-25(\*) to 9.5 mc. Reduce the output of the AN/URM-25(\*) as required to maintain a TS-505(\*)/U indication of less than 5 volts.

*d.* Adjust the slugs of tuned circuits Z219, Z220, and Z221 for a peak output indication. The slugs are mounted on the first variable if. slug rack.

*e.* Adjust the MEGACYCLE CHANGE control for a reading of .07 500 on the frequency indicator.

*f.* Tune the AN/URM-25(\*) to 17.5 mc. Adjust the attenuator setting of the AN/URM-25(\*) continuously to maintain an indication of less than 5 volts on the TS-505(\*)/U.

*g.* Adjust the three trimmers mounted within the shield cans of tuned circuits Z219, Z220, and Z221 for peak output.

*h.* Repeat the procedure described in *c* through *g* above until no increase in output can be obtained.

## 81. Alignment of Rf Stages

(fig 40)

*a.* Set the FUNCTION switch to AGC, and the RF GAIN control to 10.

*b.* Connect the dc lead of the TS-505/U to DIODE LOAD terminal 14 on the rear terminal strip (TM 11-5820-357-10), and the other common lead to the receiver chassis. Adjust the TS-505(\*)/U to measure negative dc voltages of approximately 5 volts, with respect to chassis.

*c.* If preliminary adjustments (*d* below) are unnecessary, connect the AN/URM-25(\*) to the balanced antenna input terminals by connecting either antenna input terminal of BALANCED ANTENNA 125 OHM connector J108 to the receiver ground and to the ground lead of the AN/URM-25(\*). Connect the other antenna input terminal, through a 95-ohm noninductive series resistor, to the output lead of the AN/URM-25(\*). Connect a 75-ohm noninductive resistor from the output lead of the AN/URM-25(\*) to ground. Proceed with the procedure outlined in *e* below.

*d.* If preliminary adjustments are necessary because of extreme misalignment, connect the AN/URM-25(\*) through a 0.01 uf capacitor to points listed in column 6 of the chart (*j* below) instead of connecting it to the antenna input terminals, and proceed with alignment as directed in *e* through *j* below and in the chart. After completing the preliminary procedure, connect the AN/URM-25(\*) to the antenna input terminals as described in *c* above; then, repeat the alignment, making all adjustments in the order listed in the chart.

*e.* Set up the digits listed in column 2 of the chart in the first two spaces of the frequency-indicator dial with the MEGACYCLE CHANGE control. Set up the digits listed in column 3 in the last three spaces of the frequency indicator with the KILOCYCLE CHANGE control.

*f.* Tune the AN/URM-25(\*) to the frequency listed in column 4. To obtain the exact required frequency, tune the AN/URM-25(\*) for a peak indication on the TS-505(\*)/U; do not depend on the calibration of the AN/URM-25(\*).

*g.* During the alignment procedure, adjust the AN/URM-25(\*) attenuator to maintain an output indication of less than 5 volts.

*h.* When aligning rf transformers, adjust the slugs for a set of transformers while the receiver is tuned to the lower frequency indicated in the chart for that set of transformers; adjust the trimmer capacitors while the receiver is tuned to the higher frequency.

Adjust the slugs of the set of transformers listed in column 5 for peak output; then, change the frequency settings of the receiver and the AN/URM-25(\*). Adjust the trimmer capacitors of the set of transformers listed in column 6 for peak output. The trimmer capacitors are accessible through holes in the top of the shield cans; adjust them with an insulated screwdriver. For antenna transformers, adjust the trimmer capacitors mounted

nearest to the back of the receiver for peak output. Front trimmers are used to balance the antenna input circuits. Repeat the adjustments for each set of rf coils until no further change is noticeable.

i. Set the ANT. TRIM control to 0.

j. Proceed with the rf alignment by performing adjustments in the order listed in the chart below. Refer to figure 45 for location of slugs and trimmer capacitors.

1	2	3	4	5	6	7
Set of rf coils	Megacycle reading	Kilocycle reading	Signal generator frequency (tune for peak output) in kc	Adjust slugs for peak output	Adjust trimmer capacitors for peak output	Signal generator connection (preliminary alignment only)
0.5-1 mc	00	600	600	Z213 Z207 Z201 T201		E207 E207 E206 BALANCED AN-TENNA J108
	00	900	900	----	Z213 ..... Z207 ..... Z201 ..... T201 ..... (rear trimmers).....	E207 E207 E206 J108
1-2 mc.....	01	100	1,100	Z214 Z208 Z202 T202		E207 E207 E206 J108
	01	900	1,900	----	Z214 ..... Z208 ..... Z202 ..... T202 ..... (rear trimmer).....	E207 E207 E206 J108
2-4 mc.....	02	200	2,200	Z215 Z209 Z203 T203		E207 E207 E206 J108
	03	800	3,800	----	Z215 ..... Z209 ..... Z203 ..... T203 ..... (rear trimmer).....	E207 E207 E206 E206
2-8 mc.....	04	400	4,400	Z216 Z210 Z204 T204		E207 E207 E206 J108
	07	600	7,600	----	Z216 ..... Z210 ..... Z204 ..... Z204 ..... (rear trimmer).....	E207 E207 E206 J108
8-16 mc.....	08	800	8,800	Z217 Z211 Z205 T205		E207 E207 E206 J108
8-16 mc.....	15	200	15,200	----	Z217 ..... Z211 ..... Z205 ..... Z205 ..... (rear trimmer).....	E207 E207 E206 J108

1	2	3	4	5	6	7
Set of rf coils	Megacycle reading	Kilocycle reading	Signal generator frequency (tune for peak output) in kc	Adjust slugs for peak output	Adjust trimmer capacitors for peak output	Signal generator connection (preliminary alignment only)
16-32 mc.....	17	600	17,600	Z218 Z121 Z206 T206 ----	..... ..... ..... ..... Z218 ..... Z212 ..... Z206 ..... T206 ..... (rear trimmer).....	E207 E207 E206 J108 E207 E207 E206 E206 J108
	30	400	30,400			

k. Connect two 68-ohm resistors in series and connect the free ends of the BALANCED 125 OHM ANTENNA input terminals. Connect the output lead of the AN/URM-25(\*) to the junction of these resistors. Be sure that the ground lead of the AN/URM-25(\*) is connected to the receiver chassis.

l. Tune the receiver for the frequency-indicator reading listed in the first column of the chart (n below), and then tune the ANT/URM-25(\*) to this frequency for peak receiver output.

m. Adjust the trimmer capacitor closest to the front panel of the transformers listed in the second column (n below) for *minimum* output. During the alignment procedure, change the setting of the AN/URM-25(\*) attenuator to increase the output indication to approximately volts

n. Adjust the balance trimmers in the following order:

Dial reading	Transformer (front trimmer)
00 950	T201
01 900	T202
03 600	T203
13 500	T205
31 500	T206

## 82. Adjustment of Neutralizing Capacitor C525 (fig, 26)

Adjust capacitor C525 after alignment of tuning, circuits has been completed, or when the bfo signal at the IF OUTPUT 50 OHM jack is excessive.

a. Connect Voltmeter, Meter ME-30(\*)/U from IF OUTPUT 50 OHM jack to ground.

b. Remove plug P225 (fig. 20) from jack J525. Ground the center terminal of the jack with the shortest possible length of wire.

c. Make the following control settings on the receiver:

- (1) BANDWIDTH switch to 2.
- (2) RF GAIN full on.
- (3) BFO PITCH to 0.
- (4) BFO to ON.
- (5) FUNCTIONS switch to AGC.

d. Insert a screwdriver (with an insulated shank) through the hole in the main frame, and engage and turn trimmercapacitorC525 for minimum indication on the ME-30(\*)/U (TM 11-5820-357-20).

*Caution:* The screwdriver used to adjust C525 must be insulated to prevent short-circuiting bare wires within the if. subchassis. A metallic screwdriver that has a length of spaghetti tubing covering the shank is satisfactory.

## Section III. TESTING PROCEDURES

### 83. General

a. Testing procedures are prepared for use by Signal Field Maintenance Shops and Signal Service Organizations responsible for fourth echelon maintenance

to determine the signal equipment must acceptability of repaired signal equipment. These procedures set forth specific requirements that repaired signal equipment *must*

meet before it is returned to the using organization. The procedures may also be used as a guide for testing equipment repaired at third echelon if the proper tools and test equipment are available. A summary of the performance standards is given in paragraph 95.

b. Each test depends on the preceding one for certain operating procedures and, where applicable, for test equipment calibrations. Comply with the instructions preceding the chart before proceeding to the chart. Perform each test in sequence. *Do not vary the sequence.* For each step, perform all the actions required in the *Test equipment control settings* and *Equipment*

a. *Test Equipment.*

Nomenclature	Federal stock No.	Technical reference
Output Meter TS-585(*)/U <sup>a</sup> .....	6625-244-0501	TM 11-5017
Audio Oscillator TS-382(*)/U <sup>b</sup> .....	6625-192-5094	TM 11-2684A
Spectrum Analyzer TS-723A/U.....	6625-668-9418	TM 11-5097
Oscilloscope OS- 8t*)/U <sup>c</sup> .....	6625-568-4898	TM 11-1214
RF Signal Generator Set AN/URM-25(*) <sup>d</sup> .....	6625-309-5381	TM 11-5551D
	or	or
	6625-243-0562	TM 11-5551E
Electronic Multimeter TS-505(*)/U <sup>e</sup> .....	6625-243-0562	TM 11-5511 and TM 11-6625-239-12
Electronic Voltmeter ME-30(*)/U <sup>f</sup> .....	6625-669-0742	TM 11-6625-320-12

<sup>a</sup> Indication TS-585A/U, TS-585B/U, TS-585C/U, and TS-585D/U.

<sup>b</sup> Indicates TSI 382A/U, TS-382B/U, TS-382D/U, and TS-382E/U

<sup>c</sup> Indicates OS-8A/U and OS-8C/U.

<sup>d</sup> Indicates AN/URM-25D and AN/URM-25F.

<sup>e</sup> Indicates TS-505/U, and TS-505A/U through TSD 505D/U.

<sup>f</sup> Indicates ME-30A/U and ME-30B/U.

b. *Materials and Other Equipment.*

Nomenclature	Federal stock No.	Technical reference
Power Cable Assembly CX-1358/U (supplied with receiver).....	5995-173-8839	None
Headset HS-3~U.....	5965-164-7259	None
Telephone Plug PJ-055-B (or equivalent).....	5935-192-4760	None
Electronic Equipment Maintenance Kit MK-288/URM.....	6625-557-5716	TB SM 319

**85. Special Test Facilities**

It is desirable but not mandatory that these tests be conducted in a screen room.

a. The chassis should be connected to a suitable ground for all tests.

b. The 115/230-volt ac switch located on the power supply subchassis must be in the position corresponding to the power source used.

c. Power Cable Assembly CX-1358/U is required to connect the power source to the receiver.

d. The location and labeling of certain controls

*under test control settings* columns; then, perform each specific test procedure and verify it against its performance standard.

**84. Test Equipment, Tools, and Materials**

All test equipment and other equipment required to perform the testing procedures given in this section are listed in the following charts and are authorized under TA 11-17, and TA 11-100 (11-17) or are repair part items of the subject equipment authorized for stockage at fourth echelon levels.

and receptacles differ on RF Signal Generator AN/URM-25D and RF Signal Generator AN/URM-25F. Reference to controls and control settings in the tests that follow apply to RFSignalGeneratorAN/URM-25F. The corresponding controls and control settings for RF Signal Generator AN/URM-25D are included in parentheses immediately below or adjacent to those for RF Signal Generator AN/URM-251E. When RF Signal Generator AN/URM-25D is used in the audio distortion test (fig. 52), Cord CG-409A/U

(p/o the AN/URM-25) is used in place of Telephone Plug PL-055-B. In step 2b, paragraph 91, Headset HS-30-117 cannot be plugged into the CAL OUT connection on the AN/UR\1-25D. Cord 409A/U, Adapter Connector UG-514/1, (p/o the TS-382/U), and test leads are used to make this connection.

e. Reference to RANGE switch selections in the chart apply to Electronic Multimeter TS-505A/U, TS-505B/U, TS-505C/U, and TS-505D/I5. Corresponding control settings for the TS-505/U appear in parentheses immediately below or adjacent to those for the lettered models.

f. Reference to controls and control settings in the charts apply to Audio Oscillators TS-382B/U, TS-382D/U, and TS-382E/U. Corresponding controls or control settings which differ for the TS-382A/U appear

in parentheses immediately below or adjacent to those for the TS-382B/U, TS-382n/U, and TS-382E/ U.

g. The location and labeling of certain controls and connectors differ on Oscilloscopes OS-8A/U and OS-8C/U. Reference to controls and control settings in the charts apply to Oscilloscope OS-8C/U. The corresponding controls or control settings for Oscilloscope OS-8A/U are included in parentheses immediately below or adjacent to those for Oscilloscope OS-8C/U.

## 86. Modification Work Orders

The performance standards listed in the tests (para 87-95) assume that the modification work order listed below has been performed. A listing of all current modification work orders will be found in DA Pamphlet 310-4.

MWO No.	Date	Priority	Echelon	Location of MWO marking	Remarks
SIG 11-5820-294-35/1	Nov 58	N	2	Upper right-hand corner of back panel.	Applied to all equipments w/o high-voltage fuse H.V. 3/8A.

## 87. Physical Tests and Inspections

- a. Test Equipment and Materials.* None required.  
*b. Test Connections and Conditions.* None required.  
*c. Test Procedure.*

Step No.	Test equipment control setting	Equipment under test control settings	Test procedure	Performance standards
1	None .....		Inspect equipment for modification work orders. Note any MWO's not performed.	All MWO's performed should be properly marked on receiver.
2	None .....	Same as step 1 .....	<p><i>a.</i> Check the LOCAL GAIN, RF GAIN, ANT. TRIM LIMITER LINE GAIN, and BFO PITCH controls for smooth operation, free from binding throughout their limits of travel.</p> <p><i>b.</i> Check the BANDWIDTH, BFO, AUDIO RESPONSE, LINE METER, AGC, BREAK IN FUNCTION and OVENS switches for correct operation.</p> <p><i>c.</i> Adjust the KILOCYCLE CHANGE control for an indication of 500 on the indicator. (Megacycle indicators may be at any setting.) Turn the DIAL LOCK control to its extreme clockwise position (thumb tight). Attempt to change the KILOCYCLE CHANGE control position clockwise and counterclockwise. Observe the kilocycle indicators.</p> <p><i>d.</i> Disengage DIAL LOCK control</p> <p><i>e.</i> Turn the KILOCYCLE CHANGE and MEGACYCLE CHANGE controls throughout their entire range of travel. Observe operation of the controls.</p>	<p><i>a.</i> All controls should operate freely without binding.</p> <p><i>b.</i> All switches should operate freely without binding. Detent action should be positive.</p> <p><i>c.</i> Kilocycle indicators should remain at 500.</p> <p><i>d.</i> None.</p> <p><i>e.</i> Controls should turn smoothly without binding or jamming MEGACYCLE CHANGE control should have positive detent action at each megacycle setting.</p>
3	None .....	Same as step No. 1 .....	<p><i>a.</i> Inspect the LINE LEVEL and CARRIER LEVEL meters for broken glass or damaged pointers.</p> <p><i>b.</i> Inspect frequency-indicator panel for broken glass.</p> <p><i>c.</i> Inspect all connectors, fuses, terminal boards, rear-panel terminal-strip jumpers, pin straighteners, Tube pullers, screwdriver fluted socket wrench, and coverplates for damage, missing parts, or incorrect fuse ratings. Inspect case front</p>	<p><i>a.</i> Meters should be in good condition.</p> <p><i>b.</i> Panel should be in good condition.</p> <p><i>c.</i> None of the listed items should be missing or damaged. Fuses should be of correct rating.</p>

- and rear for missing screws, nuts, or bolts.
- d. Inspect receiver front and rear and top and bottom dust covers for physical damage (dents, punctures, or bent areas).
  - e. Inspect receiver for condition of finish and panel markings.

- d. There should be no dents, punctures, or bent areas.
  - e. Painted surfaces should show no bare metal. Panel markings should be legible. *Do not paint the rear panel.*
- Note:* Touchup pointing is recommended instead of refinishing whenever practicable. Screw heads, receptacles and carrying handles must not be painted or polished with abrasives.

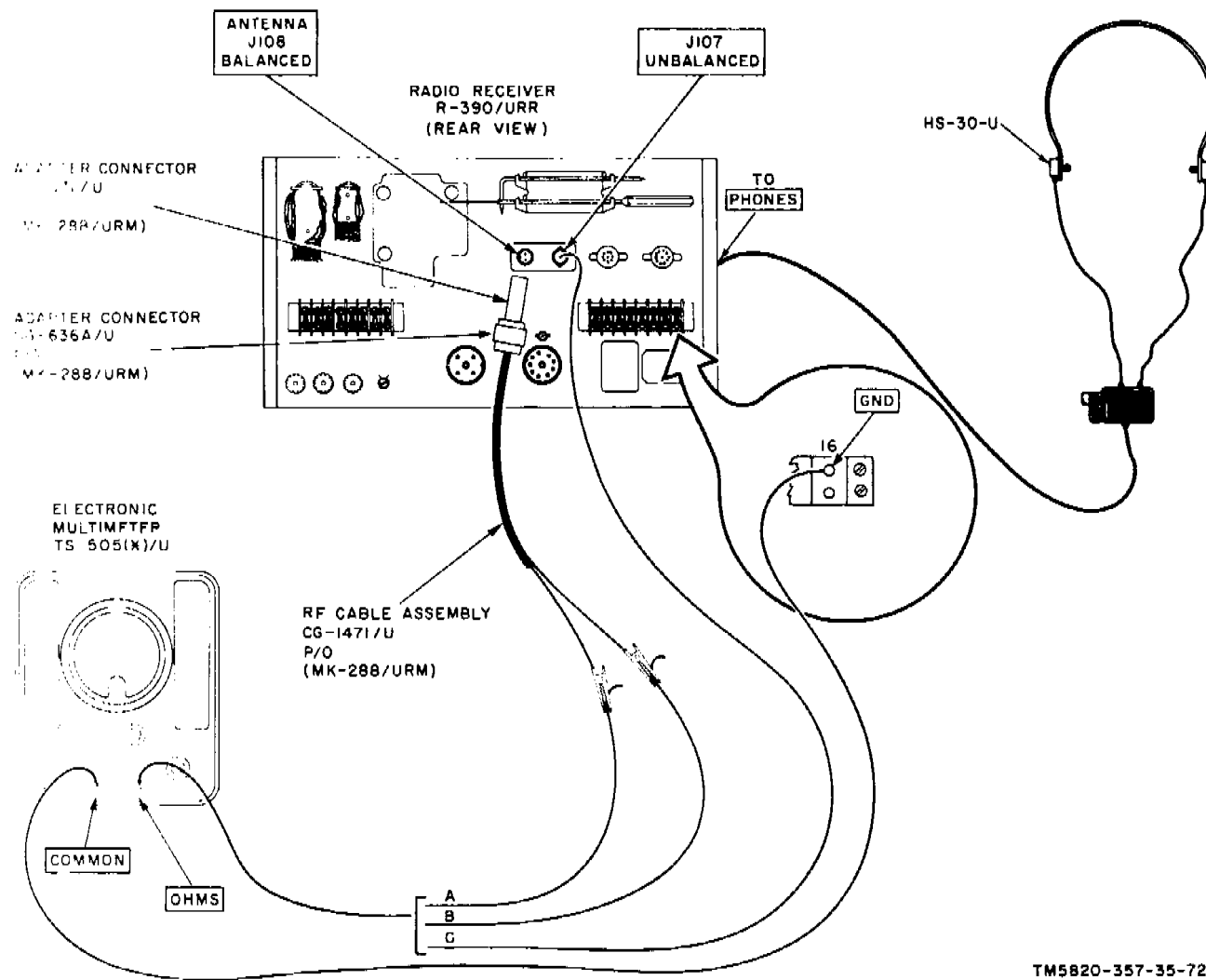

TM5820-357-35-72

Figure 47. Calibration and antenna relay test setup.

**88. Calibration and Antenna Relay Tests**

(fig. 47)

*a. Test Equipment and Materials.*

Headset HS-30-U.

Electronics Equipment Maintenance Kit MK-288/URM.

Electronic Multimeter TS-505(\*)/U.

*b. Test Connections and Conditions.* Turn on Electronic Multimeter TS-505(\*)/U and allow it to warm up for at least 5 minutes. Do not connect the TS-505(\*)/U until instructed to do so in the test procedure.

*c. Test Procedure*

Step No.	Test equipment control setting	Equipment under test control settings	Test procedure	Performance standards
1	None .....	OVENS: OFF RF GAIN: 10 LINE METER: OFF LINE GAIN: 0 LIMITER: OFF AUDIO RESPONSE: MED. FUNCTION: CAL BREAK IN: OFF BFO: ON AGC: MED. BFO PITCH: 0 DIAL LOCK: Unlocked ZERO ADJ. Disengaged LOCAL GAIN: 0 MEGACYCLE CHANGE and KILOCYCLE CHANGE: Set for 04 000 BANDWIDTH: .	<i>a.</i> Adjust KILOCYCLE CHANGE and ANT. TRIM controls for s maximum indication on the CARRIER LEVEL meter. Note the setting of the receiver frequency indicator.  <i>b.</i> If frequency indicator does not indicate exactly 04 000 proceed as follows: otherwise continue to step No. 1 (1) Adjust the KILOCYCLE CHANGE control for a frequency indicator setting of 04 000. (2) Turn the ZERO ADJ. control fully clockwise. (3) Turn the LOCAL GAIN control until an audible tone is heard in the headset. (4) Adjust the KILOCYCLE CHANGE control slowly until a zero beat is obtained in the headset and the CARRIER LEVEL meter is at a peak indication. The	<i>a.</i> None.  <i>b.</i> As follows:  (1) None  (2) None.  (3) None.  (4) A peak indication must be obtained when the frequency indicator is set at 04 000.
		Same as step NO. 1 except: Set KILOCYCLE CHANGE and MEGACYCLE CHANGE as indicated in <i>Test procedure</i> column 04 300.	Repeat step NO. 1 for the frequencies listed below: 04 100 04 200 04 300 04 400 04 500 04 600 04 700 04 800 04 900 04 +000 Repeat step No. 1 for the frequencies listed below: 31 000 31 100 31 200 31 300 31 400 31 500 31 600 31 700 31 800 31 900 31 +000	Same as step NO. 1 <i>b</i> (4).
3	TS-505(*)/U: FUNCTION: OHMS RANGE: R X 1	Same as step No. 1.....	<i>a.</i> Connect the equipment as shown in A, figure 47 <i>b.</i> Turn the receiver FUNCTION switch to STAND BY and CAL while observing the TS-505(*)/U meter. <i>c.</i> Connect the equipment as shown <i>d.</i> Repeat <i>b</i> above ..... <i>e.</i> Connect the equipment as shown in C. figure 47. Turn the TS-505 (*)/U RANGE switch to R X 10K. <i>f.</i> Repeat <i>b</i> above	<i>a.</i> TS-505(*)/U indication is infinite. <i>b.</i> TS-505(*)/U indication is zero.  <i>c.</i> Same as <i>a</i> above. <i>d.</i> Same as <i>b</i> above. <i>e.</i> TS-505(*)/U indicates 220K. ohms.  <i>f.</i> . Same as <i>b</i> above.

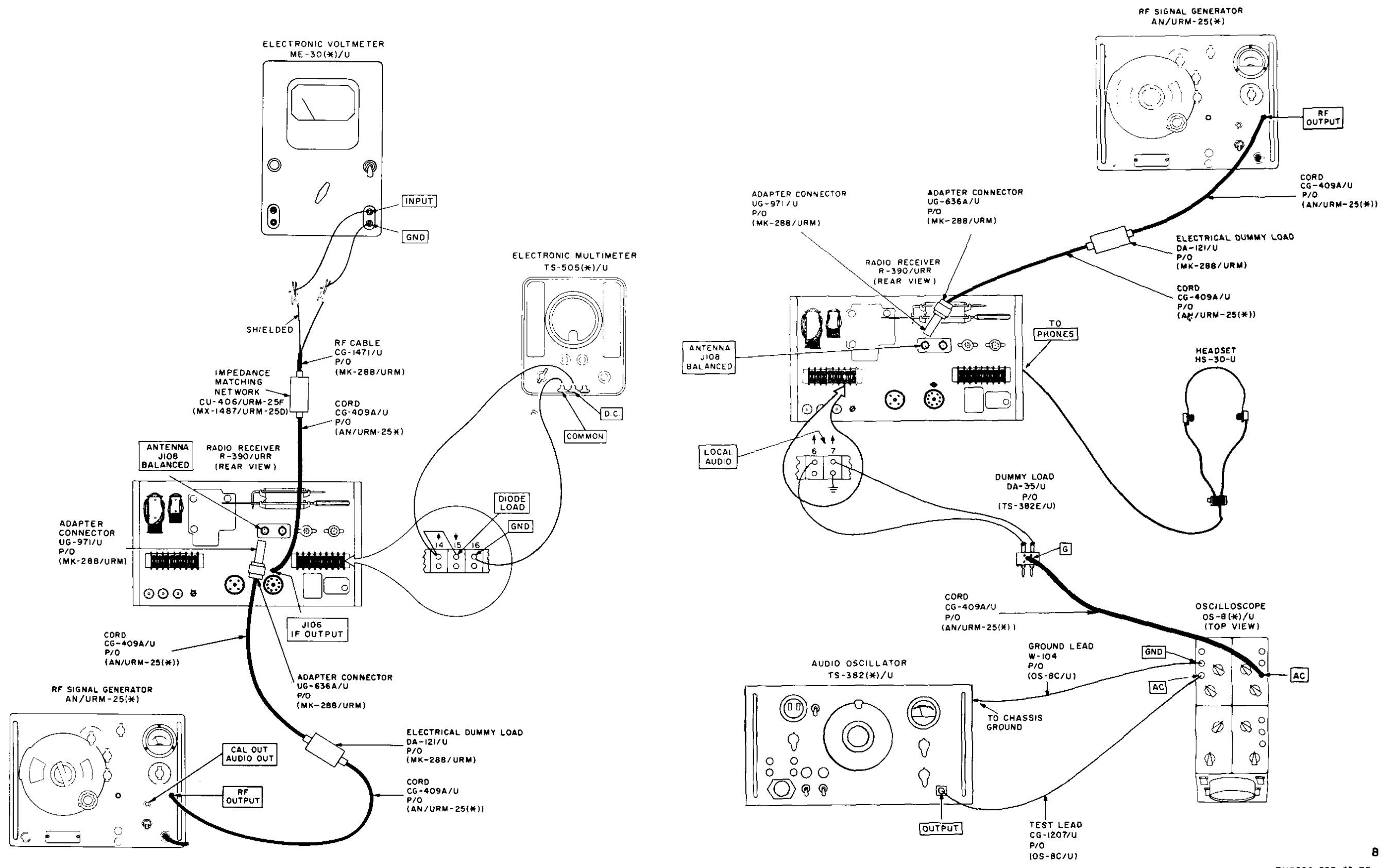

Figure 48. If. output and bfo calibration test setup.

## 89. If. Output and BFO Calibration Tests

(fig. 48)

### a. Test Equipment and Materials.

RF Signal Generator AN/URM-25F.

Electronic Equipment Maintenance Kit MK-288/URM.

Electronic Voltmeter ME-30(\*)/U.

Oscilloscope OS-8(\*)/U.

Audio Oscillator TS-382(\*)/U.

Electronic Multimeter TS-505(\*)/U.

Headset HS-30-U.

### b. Test Connections and Conditions.

Connect the equipment as shown in A, figure 48. Turn on all test equipment and allow it to warm up for 15 minutes.

### c. Test Procedure.

Step No.	Test equipment control setting	Equipment under test control settings	Test procedure	Performance standards
1	<p>TS-505(*)/U: FUNCTION: -D. C. ME-30(-)/U: RANGE: 50 V (40 V) Range selector switch: .3 VOLTS. AN/URM-25F: ATTENUATOR: 10 R. F. MULTIPLIER: X 10) FUNCTION SWITCH: CW (MOD. XTAL. &amp; METER SELECTOR: CW) (Carrier range switch: 300 KC-50 MC X MULT) SET RF OUTPUT: Maximum counterclockwise</p>	<p>RF GAIN: LINE METER: OFF LINE GAIN: 0 AGC: MED LIMITER: OFF AUDIO RESPONSE: WIDE BANDWIDTH: 8 BFO PITCH: 0 BREAK IN: OFF FUNCTION: MGC ANT. TRIM: 0 BFO: OFF DIAL LOCK: Unlocked ZERO ADF.: Disengaged LOCAL GAIN: 5 OVENS: OFF</p> <p>MEGACYCLE CHANGE and KILOCYCLE CHANGE: Set for 01 510</p>	<p>a. Adjust the AN/URM-25F SET RF OUTPUT control (carrier control) clockwise until the meter indicates full scale (10). b. Turn the AN/ URM-25F MICROVOLTS control counterclockwise until the meter indicates 3 microvolts (top scale). c. Adjust the AN/URM-25F TUNING control (main tuning dial) for a maximum indication on the TS-505(*)/U meter. Adjust receiver ANT. TRIM control for maximum indication on the TS-505(*)/U meter. d. Turn the ME-30(*)/U range selector switch to .1 VOLTS. e. Adjust the receiver RF GAIN control for an indication of 20 millivolts on the ME-30(*)/U meter. f. Set the AN/ URM-25F ATTENUATOR (R. F. MULTIPLIER) to 100. Adjust the MICROVOLTS control for 30-microvolt indication on the meter (3 on top scale). g. Note and record the indication on the ME-30(*)/U meter. h. Disconnect the ME-30(*)/U and</p>	<p>a. None. b. None. c. None. d. None. e. None. f. None.</p>
2	<p>Same as step No. 1 except: TS-382(*)/U OUTPUT CONTROL: Maximum counterclockwise OUTPUT MULTIPLIER: X .1 VOLTS (ATTENUATOR: .1) FREQUENCY MULTIPLIER: X100 (RANGE: X100) Main tuning dial: 30</p> <p>OFF-INT: Clockwise (IN TENSITY: on) VERNIER FREQUENCY: 20 (SWEEP VERNIER: 20) COARSE FREQUENCY: 2900/17.5 KC (SWEEP RANGE: 2 KC-10 KC)</p> <p>HOR. ATTEN. (C model only): SWEEP VERT. GAIN: 60 (Y GAIN: 60) HOR. GAIN: 30 (X GAIN: 30) VERT. ATTEN.: 100 (VERT. ATTEN.: AC 100.1) SYNC SELECTOR: INT. LOCKING: 0 (SYNC AMPLITUDE: 0)</p>	<p>Same as step No. 1 except: LOCAL GAIN 3</p>	<p>a. Connect the equipment as shown in B. figure 48. b. Adjust the AN/URM-25F SET RF OUTPUT control (carrier control) for a full-scale indication on the meter (10). c. Turn the receiver BFO switch to ON and adjust the KILOCYCLE CHANGE control for a zero beat in the HS-30-U. d. Adjust all controls on the front panel of the oscilloscope for a clear sharply defined centered trace. e. Set the BFO PITCH control to -3 and adjust the OS-8 (*)/U VERNIER FREQUENCY (SWEEP VERNIER) control unit I sine-wave cycle is obtained on the scope. f. Set OS-8(*)/U HOR. ATTEN. (OS-8C/U only) to 1. g. Adjust the TS-382(*)/U OUTPUT CONTROL (OUTPUT LEVEL control) clockwise until the meter indicates 1. 0. Adjust the TS-382(*)/U main tuning dial until a circular pattern is obtained on the OS-8(*)/U. Note and record the setting of the main tuning dial. h. Return the OS-8(*)/U and TS-382(*)/U control settings to the original positions indicated in the <i>Test equipment control settings</i> column and repeat the procedure given in e through g above for a receiver BFO PITCH control setting of +3. i. Turn the receiver BANDWIDTH switch to .1, the FUNCTION switch to CAL and the BFO switch to OFF. Adjust the KILOCYCLE CHANGE control for a 01500 indication on the frequency-indicator dial. j. Adjust the KILOCYCLE CHANGE and ANT. TRIM controls for a maximum indication on the receiver CARRIER LEVEL meter. k. Turn the BFO switch to ON and adjust the BFO PITCH control for a zero beat in the HS-30-U headset. Note the setting of the BFO PITCH control.</p>	<p>d. e. f. g. The TS-382(*)/U main tuning dial setting should be between 24 and 36. h. Same as g above. i. None. j. None. k. BFO PITCH control should be at zero setting when the zero beat is obtained.</p>

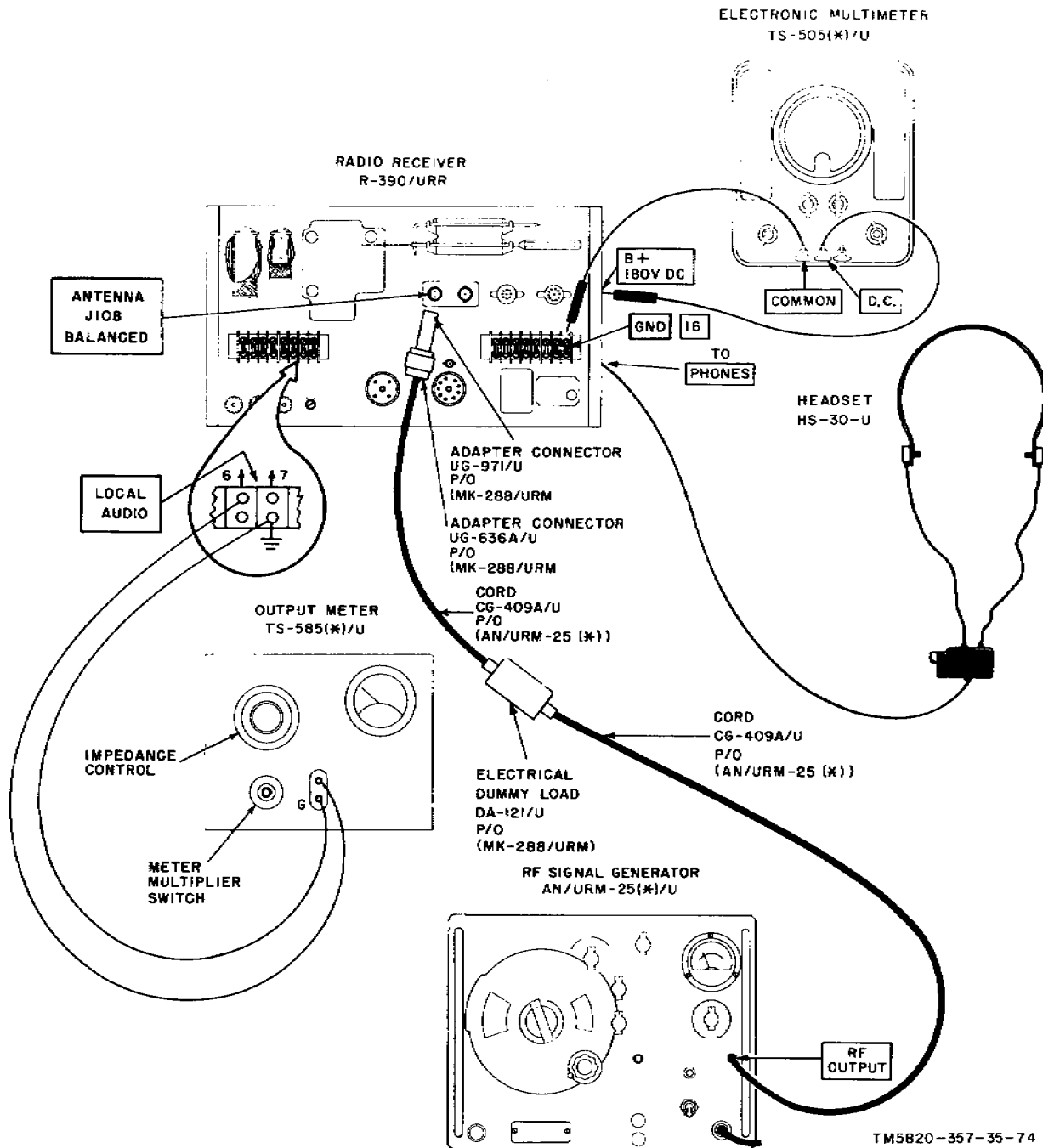

Figure 49. Sensitivity test setup.

## 90. Sensitivity Test

(fig. 49)

### a. Test Equipment and Materials.

Electronic Multimeter TS-505(\*)/U.

Output Meter TS-585(\*)/U.

RF Signal Generator AN/URM-25F.

Electronic Equipment Maintenance Kit MK-288/URM.

Headset HS-30-U.

### b. Test Connections and Conditions. Connect the equipment as shown in figure 49. Do not connect the TS-505(\*)/U until the test procedure calls for it,

### c. Test Procedure.

Step No.	Test equipment control setting	Equipment under test control settings	Test procedure	Performance standards
1	<p>TS-505(*)/U: FUNCTION: + D. C. RANGE: 250 V (400 V)</p> <p>AN/URM-25F: ATTENUATOR: 10 (R. F. MULTIPLIER: X 10). MICROVOLTS: MAX maximum clockwise). FUNCTION SWITCH: CW. (MOD, XTAL &amp; METER SELECTOR: CW). % MOD AUDIO OUT LEVEL:  maximum counterclockwise. SET RF OUTPUT: Maximum counterclockwise. (Carrier control: Maximum counterclockwise). (Carrier range switch: 300 KC-50 MC X MULTI BAND SWITCH: 0.6-1.5. (Frequency band switch: 300-950KC). TUNING: .750 (main tuning dial: .750). TS-585(*)/U: Impedance control: 60 x 10. Meter multiplier switch: 100.</p>	<p>OVENS: OFF LOCAL GAIN: 10 RF GAIN: 10 BREAK IN: OFF LIMITER: OFF BFO PITCH: 0 AGC: MED. BFO: ON BANDWIDTH KC: 16 AUDIO RESPONSE: MED. LINE METER: OFF FUNCTION: MGC</p> <p>MEGACYCLE CHANGE and KILOCYCLE CHANGE: set for 00 750. LINE GAIN: 0</p>	<p>a. Short the TS-505(*)/U DC and COMMON probe tips together, and turn the ZERO ADJ. control until the meter pointer indicates exactly 0 volt. Connect the TS-505(*)/U as shown in figure 49.</p> <p>b. Note and record indication on the TS-505(*)/U meter</p> <p>c. Disconnect the TS-505(*)/U from the receiver.</p> <p>d. Turn the AN/URM 2 5F SET RF OUTPUT (carrier control) clockwise until the AN/URM-25F meter indicates full scale (10).</p> <p>e. Adjust the receiver ANT. TRIM control for a peak indication on the TS-585(*)/U meter</p> <p>f. Turn the receiver BFO switch to OFF and the AN/URM-25F MICROVOLTS control maximum counterclockwise</p> <p>g. Set the TS-585(*)/U meter multiplier switch to 1</p> <p>h. Adjust the receiver LOCAL GAIN control for a 1-milliwatt indication on the TS-585(*)/U meter.</p> <p>i. Turn the AN/URM-25F FUNCTION SWITCH to 400 and adjust the % MOD AUDIO OUT LEVEL control for an indication of 30 on the % MOD scale of the AN/URM-25F meter.</p> <p>j. Turn the AN/URM-25F MICROVOLTS control clockwise until the TS-585(*)/U meter indicates 10-milliwatts.</p> <p>k. Adjust the receiver ANT. TRIM control for a peak indication on the TS-585(*)/U meter.</p> <p>l. Set the AN/URM-25F FUNCTION SWITCH to CW. Readjust the receiver LOCAL GAIN control for 1-milliwatt indication on the TS-585(*)/U meter</p> <p>m. Turn the AN/URM-25F FUNCTION SWITCH to 400 and readjust the MICROVOLTS control for a 10-milliwatt indication on the TS-585(*)/U meter.</p> <p>n. Repeat l and m above if necessary, until the TS-585(*)/U meter indicates 1 milliwatt with the AN/URM-25F FUNCTION SWITCH at CW, and 10 milliwatts in the 400 position.</p> <p>o. Set the AN/URM-25 F FUNCTION SWITCH to CW and observe the AN/URM-25F meter indication. Note this indication.</p>	<p>a. None.</p> <p>b. The TS-505(*)/U meter should indicate between 175 and 185 volts dc.</p> <p>c. None.</p> <p>d. None.</p> <p>e. None</p> <p>f. None.</p> <p>g. None</p> <p>h. None.</p> <p>i. None.</p> <p>j. None.</p> <p>k. None.</p> <p>l. None.</p> <p>m. None.</p> <p>o. The AN/URM-25F meter should indicate not more than 4.0 microvolts.</p>
2	<p>Same as step No. 1, except: AN/URM-25F. BAND SWITCH: 3 S- 10 (Frequency band switch: 3.0-9.5 MC) TUNING: 6.0 (Main tuning dial: 6.0)</p>	<p>Same as step No. 1 except: MEGACYCLE CHANGE and KILOCYCLE CHANGE: Set for 06 000.</p>	<p>Repeat step No. 1d through 1o above.</p>	<p>Same as step No. 1.</p>
3	<p>Same as step No. 1, except: AN/URM-25F. BAND SWITCH: 10-25 (Frequency band switch: 9.5-30 MC) TUNING 14.0 (Main tuning dial: 14.0)</p>	<p>Same as step No. 1 except: MEGACYCLE CHANGE and KILOCYCLE CHANGE: Set for 14 000.</p>	<p>Repeat step No. 1d through 1o above.</p>	<p>Same as step No. 1.</p>
4	<p>Same as step No. 1, except: AN/URM-25F. BAND SWITCH 25-50 (Frequency band switch: 9.5-30 MC) TUNING: 20 (Main tuning dial: 20)</p>	<p>Same as step No. 1 except: MEGACYCLE CHANGE and KILOCYCLE CHANGE: Set for 20 000.</p>	<p>Repeat step No. 1d through 1o above.</p>	<p>Same as step No. 1d through 1n in above. The AN/URM 25F meter should indicate not more than 5.0 MICROVOLTS.</p>
5	<p>Same as step No. 1, except: AN/URM-25 F. BAND SWITCH: 25-50 (Frequency band switch: 9.5-30 MC) TUNING: 26 (Main tuning dial: 26)</p>	<p>Same as step No. 1 except: MEGACYCLE CHANGE and KILOCYCLE CHANGE: Set for 26 000.</p>	<p>Repeat step No. 1d through 1o above.</p>	<p>Same as step No. 4.</p>
6	<p>Same as step No. 1, except: AN/VRM-25F. BAND SWITCH: 25-50 (Frequency band switch: 9.5-30 MC) TUNING: 30 (Main tuning dial: 30)</p>	<p>Same as step No. 1 except: MEGACYCLE CHANGE and KILOCYCLE CHANGE: Set for 30 000.</p>	<p>Repeat step No. 1d through 1o above.</p>	<p>Same as step No. 4.</p>
7	<p>Same as step No. 1, except: AN/VRM-25F. ATTENUATOR: 1 (R. F. MULTIPLIER: X 1)</p>	<p>Same as step No. 1</p>	<p>a. Turn AN/URM-25F SET RF OUTPUT (carrier) control until the meter indicates full scale (10).</p> <p>b. Adjust the receiver ANT. TRIM control for a peak indication on the TS-585(*)/U meter.</p> <p>c. Adjust the receiver KILOCYCLE CHANGE control for a dip in the TS-585(*)/U meter indication and a zero beat in the headset.</p> <p>d. Turn the AN/URM-25F MICROVOLTS control counterclockwise and the receiver BFO switch to OFF.</p> <p>e. Set the TS-505(*)/U meter multiplier switch to I and adjust the receiver LOCAL GAIN control for a 1-milliwatt indication on the TS-585(*)/U meter.</p> <p>f. Adjust the AN/URM-25F MICROVOLTS control until the TS-585(*)/U meter indicates 10 milliwatts. Note and record the AN/URM-25F meter indication. (microvolts scale).</p> <p>g. Repeat steps a through f above for the frequencies indicated below. Use the control settings as indicated in the Test equipment control settings column of steps 2 through 6, except leave the ATTENUATOR on 1 for the AN/URM 25-D.</p> <p style="text-align: center;">Frequencies (mc) 6 14 20 26 30</p>	<p>a. None.</p> <p>b. None.</p> <p>c. None.</p> <p>d. None.</p> <p>e. None.</p> <p>f. The AN/URM-25F meter should indicate not more than 1 microvolt.</p> <p>g. Same as f above.</p>

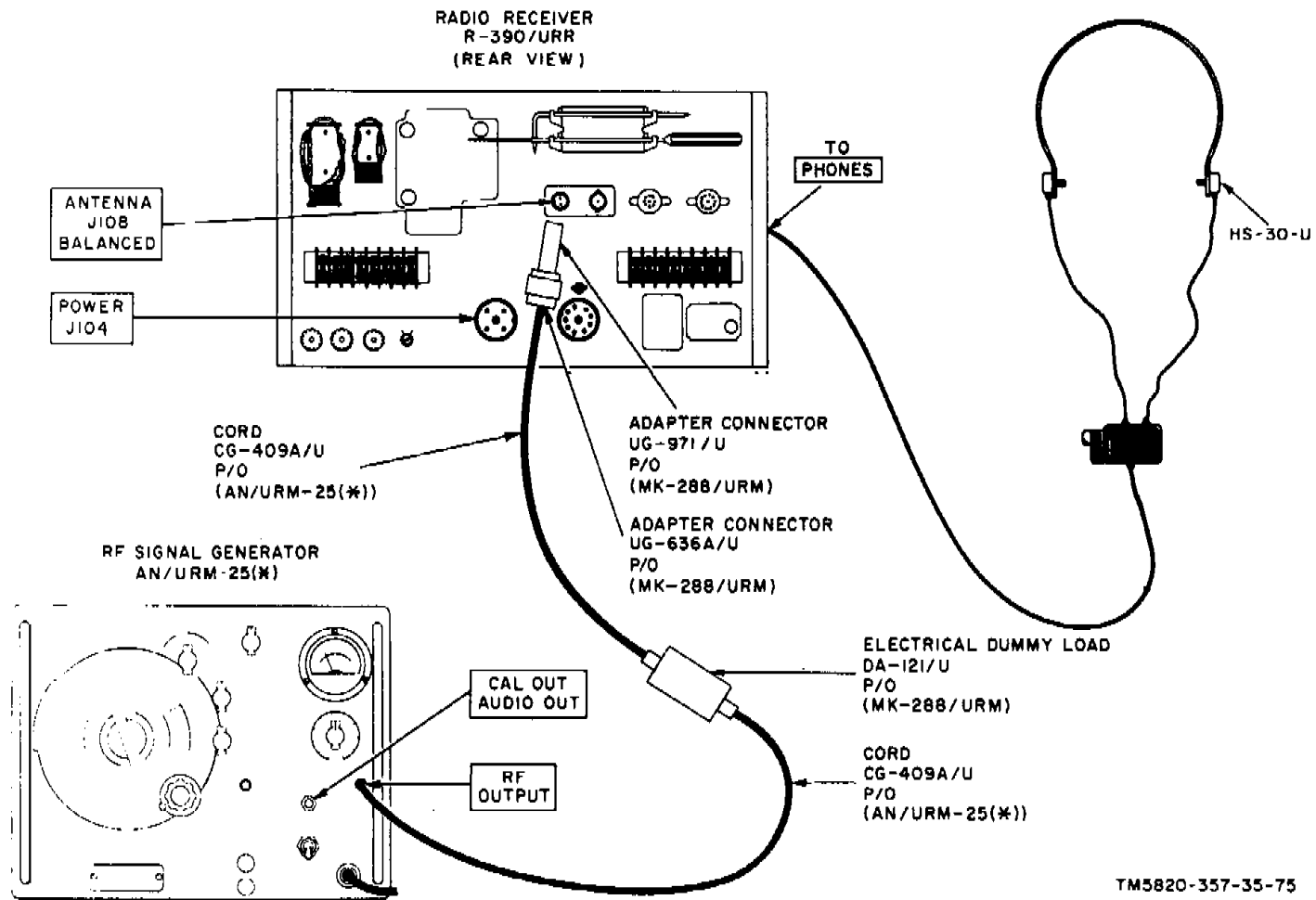

Figure 50. Line level meter, limiting, and squelch test setup.

**91. Line Level Meter, Limiting, and Squelch Tests**  
(fig, 50)

*a. Test Equipment and Materials.*

RF Signal Generator AN/URM-25F,  
Electronic Equipment Maintenance Kit MK-288/URM.  
Headset HS-30-U.

*b. Test Connections and Conditions.* Connect the equipment as shown in figure 50.

*c. Test Procedure.*

Step No.	Test equipment control setting	Equipment under test control settings	Test procedure	Performance standards
1	None .....	<p>ANT. TRIM: 0</p> <p>OVENS: OFF RF GAIN: 10 LINE METER: -10</p> <p>LINE GAIN: 0</p> <p>LIMITER: OFF AUDIO RESPONSE: WIDE</p> <p>FUNCTION: CAL</p> <p>BREAK IN: OFF BFO: ON AGC: MED. BFO PITCH: 0 DIAL LOCK: unlocked ZERO ADJ.: disengaged LOCAL GAIN: 0 MEGACYCLE CHANGE and KILOCYCLE CHANGE: set for 01500. BANDWIDTH: 8</p>	<p><i>a.</i> Adjust the LOCAL GAIN and BFO PITCH controls for an audible tone heard from the HS-30-U headset.</p> <p><i>b.</i> Adjust the LINE GAIN control for a zero indication on the LINE LEVEL meter (top scale).</p> <p><i>c.</i> Turn the LINE METER switch to 0, and observe the LINE LEVEL meter indication (top scale). Record the indication.</p> <p><i>d.</i> Readjust the LINE GAIN control for a 0-VU indication on the LINE LEVEL meter (top scale).</p> <p><i>e.</i> Turn the LINE METER switch to +10. Note and record the LINE LEVEL meter indication (top scale).</p> <p><i>f.</i> Adjust the LINE METER and LINE GAIN controls for a full scale deflection (+3 VU marking on top scale) of the LINE LEVEL meter.</p> <p><i>g.</i> Turn the LIMITER control to 1 (LINE LEVEL meter indication will decrease). Readjust the LINE GAIN control for full-scale indication.</p> <p><i>h.</i> Slowly turn the LIMITER control clockwise to position 10, while observing the LINE LEVEL meter.</p>	<p><i>a.</i> None.</p> <p><i>b.</i> None.</p> <p><i>c.</i> LINE LEVEL meter should indicate -10 VU</p> <p><i>d.</i> None.</p> <p><i>e.</i> LINE LEVEL meter should indicate -10 VU.</p> <p><i>f.</i> None.</p> <p><i>g.</i> None.</p> <p><i>h.</i> LINE LEVEL meter indication should decrease smoothly with no abrupt</p>
2	<p><i>AN/URM-25F</i></p> <p>BAND SWITCH: 3. 8-10 (Frequency band switch: 9.5-30 MC)</p> <p>FUNCTION SWITCH: CW (MOD. XTAL &amp; METER SELECTOR: CW)</p> <p>% MOD AUDIO OUT LEVEL: maximum counterclockwise</p> <p>MICROVOLTS: MAX (MICROVOLTS: maximum clockwise)</p> <p>ATTENUATOR: 10 (R. F. MULTIPLIER: X 10)</p> <p>SET RF OUTPUT: maximum counterclockwise</p> <p>Carrier control: maximum counterclockwise (Carrier range switch; 300 KC-50 MC X MULT)</p> <p>TUNING: 10 (Main tuning dial: 10)</p>	<p>Same as step No. 1 except:</p> <p>MEGACYCLE CHANGE and KILOCYCLE CHANGE: set to 10 000</p> <p>PHONES jack of the receiver.</p> <p><i>e.</i> Adjust the receiver RF GAIN and LOCAL GAIN controls for a comfortable listening level heard from the HS-30-U.</p> <p><i>f.</i> Adjust the KILOCYCLE CHANGE</p>	<p><i>a.</i> Adjust the AN/URM-25F. SET RF OUTPUT control for full-scale indication on the AN/URM-25F meter (10).</p> <p><i>b.</i> Turn the AN/URM-25F FUNCTION switch to CAL. Plug the Hbi-30-U into the CAL OUT jack on the AN/URM-25F</p> <p><i>c.</i> Adjust the AN/URM-25F TUNING (main tuning dial) control for the 10 megacycle calibration zero beat.</p> <p><i>d.</i> Remove Headset HS-30-U from the AN/URM-25F and plug it into the</p> <p><i>e.</i> None.</p> <p><i>f.</i> None. control for a zero beat indication. Turn the BFO switch to OFF and then adjust the ANT. TRIM control for a Peak indication on the CARRIER LEVEL meter.</p> <p><i>g.</i> Turn the receiver FUNCTION switch to SQUELCH and the RF GAIN control to 0.</p> <p><i>h.</i> Turn the RECIEVER RF GAIN control slowly to position 10, and listen for the squelch relay to energize. Observe the noise-free output before the squelch relay energizes.</p>	<p><i>a.</i> None.</p> <p><i>b.</i> None.</p> <p><i>c.</i> None.</p> <p><i>d.</i> None.</p> <p><i>g.</i> None.</p> <p><i>h.</i> No noise should be heard in the headset until the squelch relay energizes. The squelch relay should energize before the RF</p>

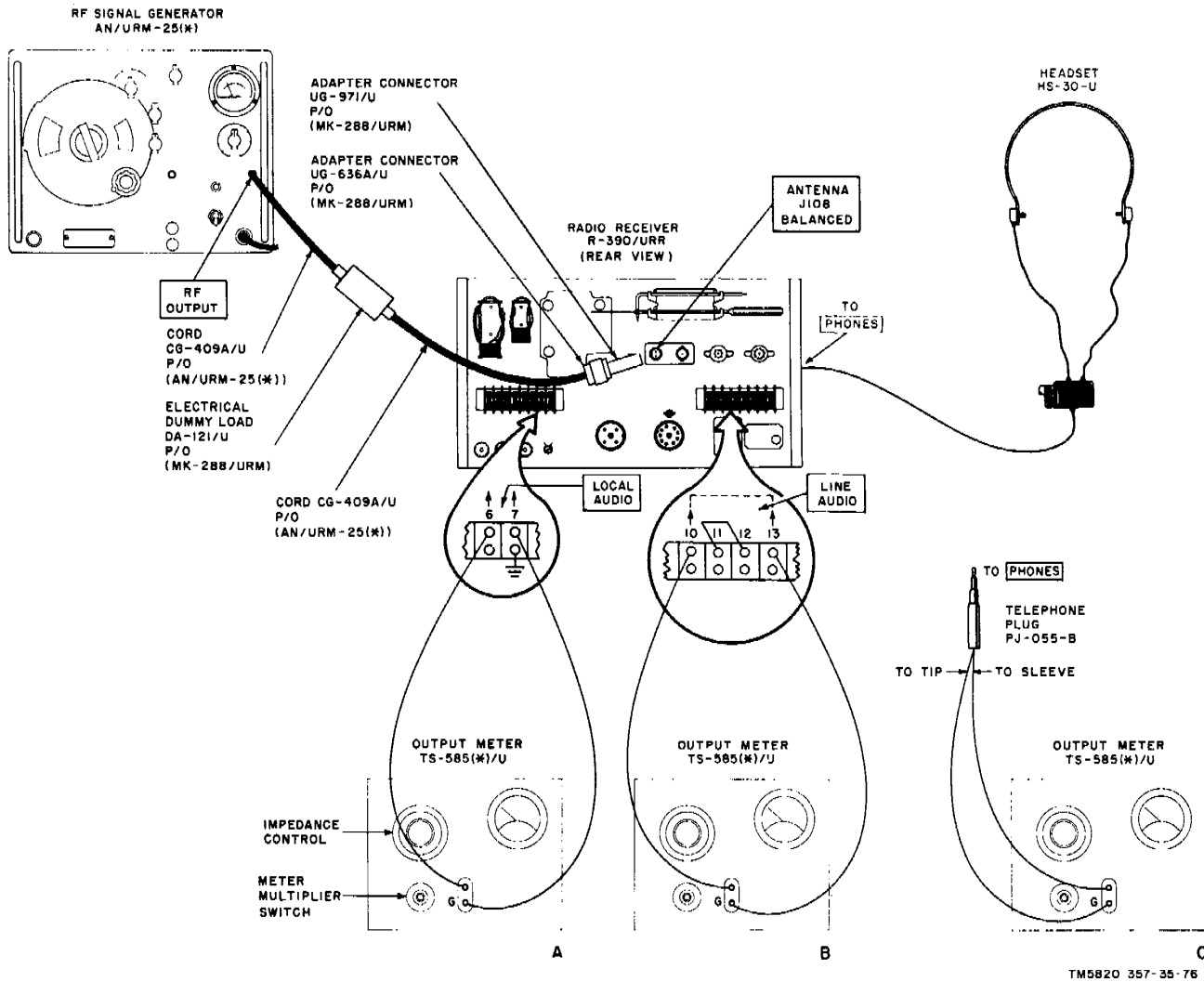

Figure 51. Audio output test setup.

## 92. Audio Output Tests

(fig. 51)

### a. Test Equipment and Materials.

Output Meter TS-585(\*)/U.

RF Signal Generator AN/URM-25F.

Electronic Equipment Maintenance Kit MK-288/URM.

Plug, Telephone PJ-055-B.

### b. Test Connections and Conditions. Connect the Equipment as shown in A, figure 51.

### c. Test Procedures.

Step No.	Test equipment control setting	Equipment under test control settings	Test procedure	Performance standards
1	TS-585(*)/U: Impedance control: 60 X 10. Meter multiplier switch 100. AN/VRM-25F: ATTENUATOR: 10. (R. F. MULTIPLIER: X 10). FUNCTION SWITCH: CW. MOD. XTAL & METER SELECTOR: CW). SET RF OUTPUT: maximum counterclockwise. (Carrier control maximum counterclockwise). (Carrier range switch: 300 KC-50 MC X MULT). % MOD AUDIO OUT LEVEL: maximum counterclockwise. MICROVOLTS: MAX (MICROVOLTS: maximum clockwise). BAND SWITCH: 1. 5-3.8 (Frequency band switch: 95-3. 0 MC). TUNING: 1.50 (Main tuning dial: 1. 50)	OVENS: OFF RF GAIN: 10 LINE METER: 0 LINE GAIN: 0 LIMITER: OFF AUDIO RESPONSE: WIDE FUNCTION: AGC BREAK IN: OFF BFO: ON AGC: MED. BFO PITCH: 0 DIAL LOCK: unlocked ZERO ADJ.: disengaged LOCAL GAIN: 10 MEGACYCLE CHANGE and KILOCYCLE CHANGE: set for 01 500. BANDWIDTH: 8 ANT. TRIM: 0	a. Adjust the AN/URM-25F SET RF OUTPUT (carrier control) until the AN/URM-25F meter indicates full scale (10). b. Adjust the receiver LINE GAIN control until a full-scale indication is obtained on the LINE LEVEL, meter. c. Adjust the AN/URM-25F TUNING(main dial) for a full (zero beat) indication on the LINE LEVEL meter (zero lower scale indication). d. Turn the receiver BFO switch to OFF. e. Turn the AN/ URM-25F FUNCTION SWITCH (MOD. XTAL 8r METER SELECTOR) to 400 and adjust the % MOD AUDIO OUT LEVEL control for a 30 percent indication on the AN/ URM-25F meter. f. Note and record the indication on the TS-585(*)/U meter. g. Turn the LINE GAIN control fully clockwise and the LINE METER switch to OFF. Reconnect the TS-585(*)/U as shown in B. figure 51. h. Set the TS-585(*)/U meter multiplier switch to 1. Note and record i. Reconnect the TS-585(*)/U as shown in C. figure 51. Note and record the TS-585(*) meter indication.	a. None. b. None. c. None. d. None. e. None. f. TS-585(*)/U meter should indicate not less than 450 milliwatts. g. None. h. TS-585(*) meter should indicate not less than 9 milliwatts. i. Reconnect the TS-585(*)/U should indicate not less than 4.5 milliwatts.

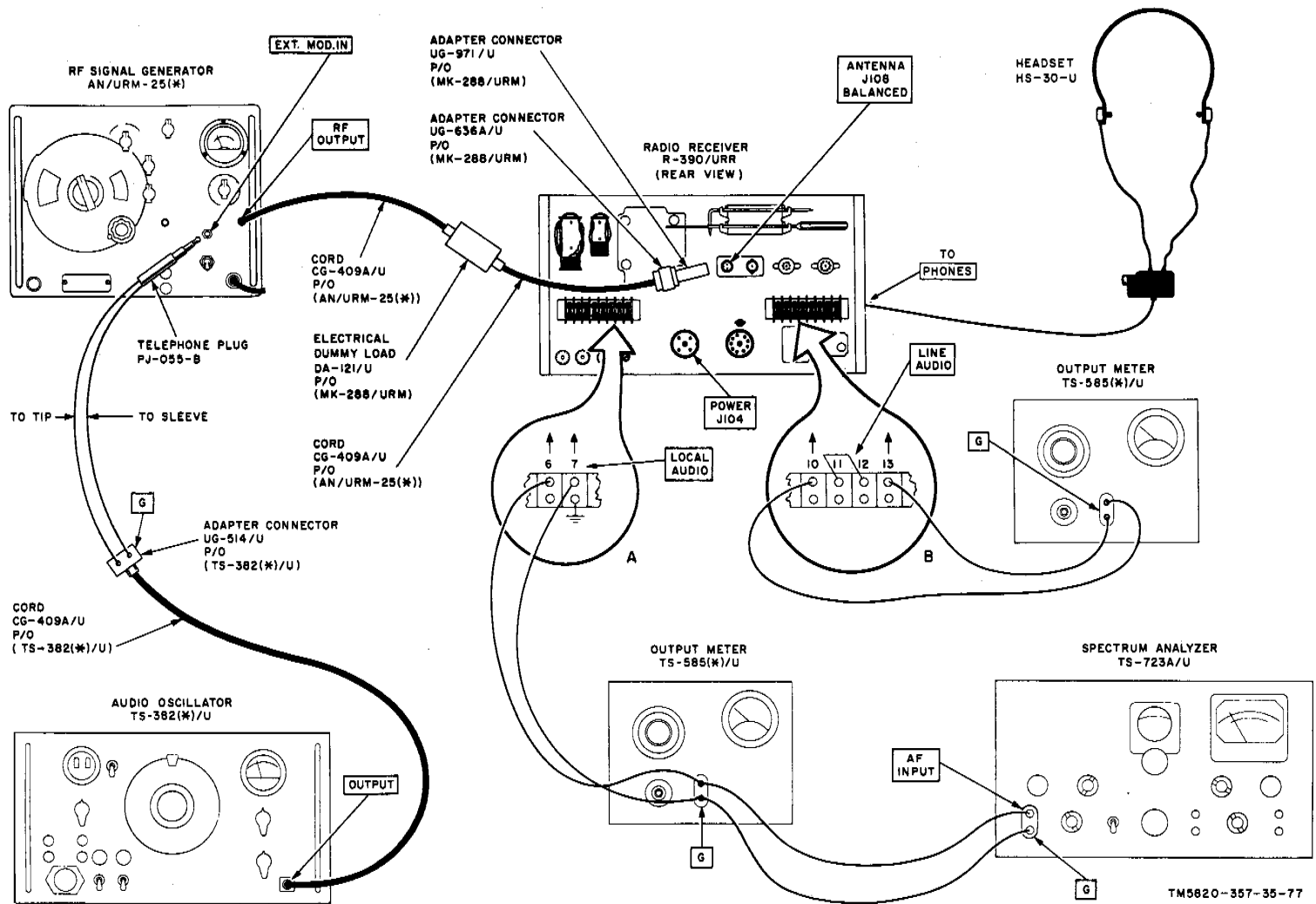

Figure 52. Audio distortion test setup.

**93. Audio Distortion Test**  
(fig. 52)

*a. Test Equipment and Materials.*

Spectrum Analyzer TS-723A/U.

Audio Oscillator TS-382(\*)/U.

RF Signal Generator AN/URM-25F.

Output Meter TS-585(\*)/U.

Electronic Equipment Maintenance Kit MK-288/URM.

Headset HS-30-U.

Telephone Plug PJ-055-B.

*b. Test Connections and Conditions.* Connect the equipments as shown in A, figure 52. Turn Spectrum Analyzer TS-723A/U on and allow it to warm up for at least 15 minutes.

*c. Test Procedure.*

Step No.	Test equipment control setting	Equipment under test control settings	Test procedure	Performance standards
1	<p>TS-723A/U: AF-RF: AF</p> <p>INPUT: MIN FREQ RANGE: X10 FREQUENCY: 100 on tuning dial Function switch: SET LEVEL Meter range switch: 100% BALANCE: maximum counterclockwise</p> <p>TS-382(*)/D: FREQUENCY MULTIPLIER: X 10 (RANGE: X 10) OUTPUT MULTIPLIER: X 10 VOLTS (ATTENUATOR: 10)</p> <p>OUTPUT CONTROL: maximum counterclockwise</p> <p>(OUTPUT LEVEL control: maximum counterclockwise) Main tuning dial: 100</p> <p>TS-585(*)/V: Impedance control: 60 X 10 Meter multiplier switch: 100</p>	<p>OVENS: OFF RF GAIN: 10</p> <p>LINE METER: OFF LINE GAIN: 10 LIMITER: OFF</p> <p>AUDIO RESPONSE: WIDE FUNCTION: AGC BREAK IN: OFF BFO: ON</p> <p>AGC: MED. BFO PITCH: 0 DIAL LOCK: unlocked ZERO ADJ.: disengaged</p> <p>LOCAL GAIN: 10 MEGACYCLE CHANGE and KILOCYCLE CHANGE: set for 01500</p> <p>BANDWIDTH KC: 8</p> <p>ANT. TRIM: 0</p>	<p><i>a.</i> Adjust the AN/URM-25F SET RF OUTPUT (carrier) control until the AN/URM-25F meter indicates full scale (10).</p> <p><i>b.</i> Adjust the AN/URM-25F TUNING (main tuning dial) for a zero beat in the HS-30-U. Turn the receiver BFO switch to OFF. Set the AN/URM-25F FUNCTION SWITCH (MOD. XTAL &amp; METER SELECTOR) to EXT</p> <p><i>c.</i> Adjust the TS-352(*)/U OUTPUT CONTROL (output level control) until the TS-382(*)/U meter indicates 1.0.</p> <p><i>d.</i> Adjust the AN/URM-25F % MOD AUDIO OUT LEVEL control until the AN/URM-25F meter indicates 30% MOD.</p> <p><i>e.</i> Measure the distortion, using the following procedure: (1) Slowly rotate TS-723A/U INPUT control clockwise until TS-723A/U meter indicates full-scale deflection (1.0). (2) Turn the TS-723A/U function switch to DISTORTION. (3) Adjust TS-723A/U upper FREQUENCY control (coarse) until a sharp dip is indicated by the meter needle. (4) Decrease the meter range switch setting to maintain near midscale indications. (5) Adjust lower FREQUENCY control (fine) for minimum meter indication. (6) Adjust BALANCE control for minimum meter indication. (7) Note and record the distortion as indicated on the TS-723A/U meter. (Read scale corresponding to meter range switch setting).</p>	<p><i>a.</i> None.</p> <p><i>b.</i> None.</p> <p><i>c.</i> None.</p> <p><i>d.</i> None.</p> <p><i>e.</i> Distortion should not exceed 10 percent.</p>
2	<p>No change from last positions of step No. 1 except:</p> <p>TS-585(*)/U Meter multiplier switch: 1</p> <p>TS-723A/U: AF-RF: AF INPUT: MIN. FREQ RANGE: X 10 FREQUENCY: 100 on tuning dial Function switch: SET LEVEL Meter range switch: 100 70 BALANCE: maximum counterclockwise</p>	<p>No change from last position in step No. 1.</p>	<p><i>a.</i> Connect the TS-585(*)/U as shown in B, Figure 52 and repeat step No. 1 <i>e.</i></p> <p><i>b.</i> Turn off the test equipment and remove all test connections from the receiver</p>	<p><i>a.</i> Distortion should not exceed 6 percent</p> <p><i>b.</i> None.</p>

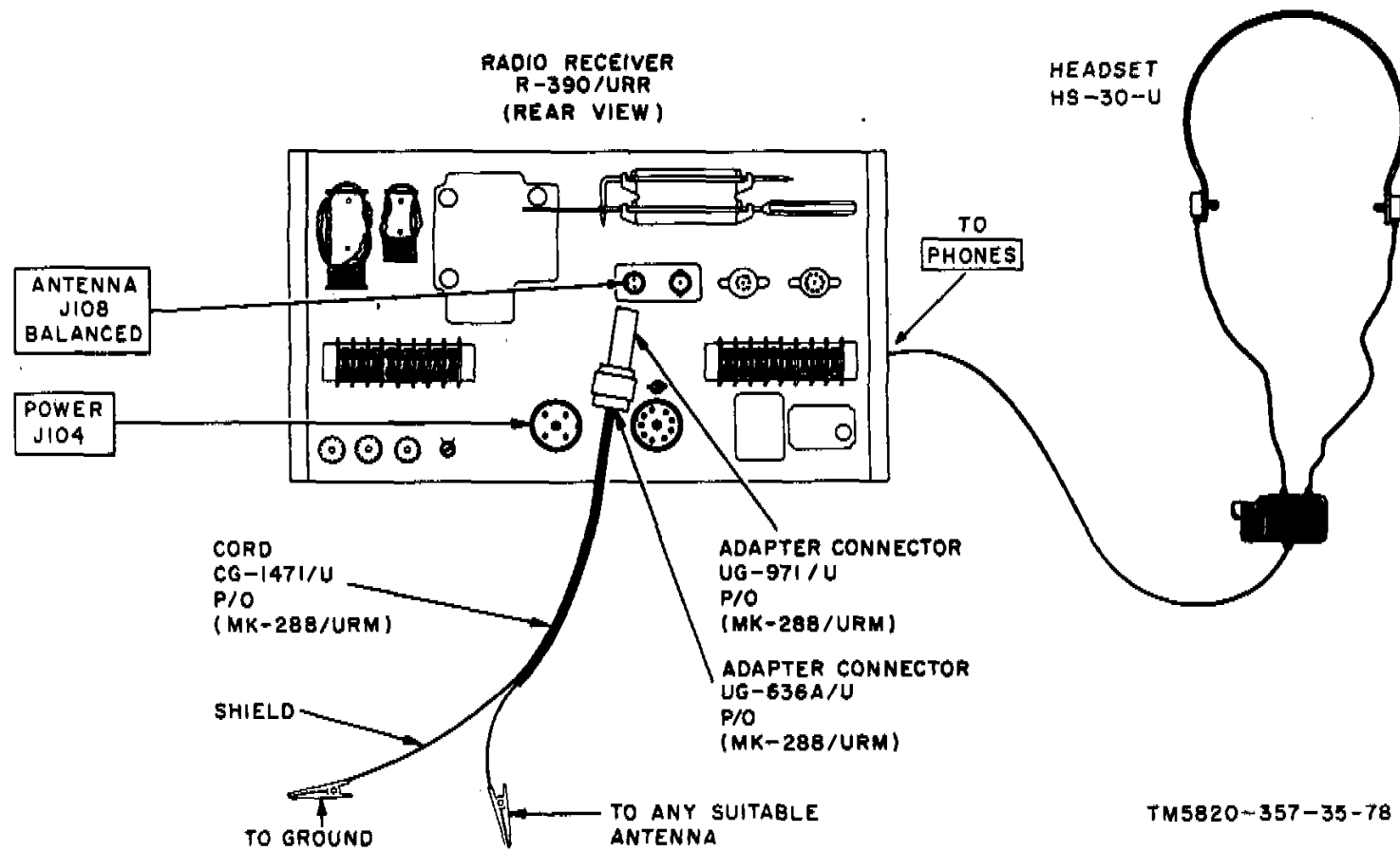

Figure 53. Operational test setup.

## 94. Operational Tests

(fig. 53)

*a. Test Equipment and Materials.*

Headset HS-30-U.

Electronic Equipment Maintenance Kit MK-288/URM

*b. Test Connections and Conditions.* Connect the equipment as shown in figure 53. Dial indicators should light.

*c. Test Procedure.*

Step No.	Test equipment control setting	Equipment under test control settings	Test procedure	Performance standards
1	None	OVENS: OFF LINE METER: OFF LINE GAIN: 0 RF GAIN: 10 AGC: FAST LIMITER: OFF AUDIO RESPONSE: WIDE BANDWIDTH: 16 BFO PITCH: 0 BREAK IN: OFF FUNCTION: AGC ANT. TRIM: 0 BFO: OFF DIAL LOCK: unlocked ZERO ADJ.: disengaged LOCAL GAIN: 5	<p><i>a.</i> Adjust KILOCYCLE CHANGE and MEGACYCLE CHANGE controls to obtain any local broadcast station or station WWV.</p> <p><i>b.</i> Turn BFO switch to ON and adjust KILOCYCLE CHANGE control for a zero beat in Headset HS-30-U. Turn the BFO switch to OFF.</p> <p><i>c.</i> Adjust ANT. TRIM control for a maximum indication on the CARRIER LEVEL meter.</p> <p><i>d.</i> While observing the CARRIER LEVEL meter indication, turn the AGC switch to MED.</p> <p><i>e.</i> While observing the CARRIER LEVEL meter indication, turn the AGC switch to FAST. original indication.</p> <p><i>f.</i> While observing the CARRIER LEVEL meter indication and listening to the HS-30-U output, turn the AGC switch to MED. then, both should return to their original indications.</p> <p><i>g.</i> Turn the BANDWIDTH switch to each of its positions and listen to the output in the HS-30-U.</p>	<p><i>a.</i> None.</p> <p><i>b.</i> None.</p> <p><i>c.</i> None.</p> <p><i>d.</i> No change should occur in the CARRIER LEVEL meter indication.</p> <p><i>e.</i> The CARRIER LEVEL meter indication should momentarily decrease, then return to its original indication.</p> <p><i>f.</i> The output from the HS-30-U should cut out and the CARRIER LEVEL meter should indicate full scale for approximately 4 seconds;</p> <p><i>g.</i> Background noise should decrease with each change to the next smaller bandwidth setting. (Amplitude of output will also decrease at the smaller bandwidth</p>

30-U and observe the CARRIER LEVEL meter indication: turn the FUNCTION switch to MGC.

- h.* Set the BANDWIDTH switch to 8.
- i.* Turn the AUDIO RESPONSE switch to MED. and listen to the Output in the HS-30-U.
- j.* Turn the AUDIO RESPONSE switch to SHARP, and listen to the output in the HS-30-U.
- k.* Turn the AUDIO RESPONSE switch to MED.
- l.* Listen to the output in the HS-30-U and the CARRIER LEVEL meter indication should increase.
- m.* Turn the FUNCTION switch to AGC.
- n.* Short out the antenna input and turn the RF GAIN control to 0. Observe the CARRIER LEVEL
- o.* Turn the FUNCTION switch to OFF, and disconnect the test equipment from the receiver,

- settings. )
- h.* None.
  - i.* There should be a decrease in the background noise.
  - j.* Fidelity of output should decrease.
  - k.* None.
  - j.* The noise level in the output of
  - m.* None.
  - n.* The CARRIER LEVEL meter should indicate 0 DB.
  - o.* None.

## 95. Performance Standard Summary

<i>Function</i>	<i>Performance standard</i>
a. If. output	180-220 mv
b. Bfo calibration	2,400-3,600 cps
c. B+ voltage	175-185 volts dc
d. Am. sensitivity (10/ 1 signal-plus-noise to noise ratio)	
<i>Frequency</i>	
(1) .750 mc	4.0 uv or less
(2) 6.0 mc	4.0 uv or less
(3) 14.0 mc	4.0 uv or less
(4) 20.0 mc	5.0 uv or less

(5) 26.0	5.0 uv or less
(6) 30.0 mc	5.0 uv or less
e. Cw sensitivity (10/1 1.0 uv or less signal plus noise-to-noise ratio)	
f. Audio output	
(1) Local audio	450 mw or more
(2) Line audio	9 mw or more
(3) Phones	4.5 mw or more
g. Audio distortion	
(1) Local audio	10% max
(2) Line audio	6% max

# CHAPTER 4

## DEPOT INSPECTION PROCEDURES

### Section I. PREPARATION

#### 96. Purpose of Depot Inspection Procedures

The tests outlined in this section are designed to measure the performance capability of a repaired R-390/URR. Equipment that meets the minimum standards in the tests will furnish satisfactory operation, equivalent to that of new equipment.

#### 97. Test Equipment and Additional Equipment Required

*a. Test Equipment.* Test equipment of the type listed below, or equivalent, is required for depot testing of Radio Receiver R-390/ URR.

Test equipment	Stock number	Quantity
1. Spectrum Analyzer TS-723/U.	6625-668-9418	1
2. Frequency Counter AN/USM-26.	6625-692-6553	1
3. Electronic Multimeter TS-505/U.	6625-243-5381	1
4. Rf Signal Generator AN/URM-25D.	6625-309-5381	1
5. Voltmeter, Meter ME-30A/U.	6625-669-0742	1
6. Signal Generator AN/USM-44.	6625-669-4031	1

#### *b. Additional Equipment Required.*

Additional equipment	Stock number	Quantity
1. Headset, 600-ohm---	5965-164-7259	1
2. Resistor, composition, 60-ohm, 1/2-w, ±5%.	5905-279-2980	1
3. Resistor, composition, 62-ohm, 1/2-w, ±5%.	5905-101-9429	3
4. Resistor, composition, 600-ohm, 1/2-w, ±5%	5905-259-2890	2
5. Resistor, composition, 68-ohm, 1/2-w, ±5%.	5905-195-5571	1
6. Resistor, composition, 33-ohm, 1/2-w, ±5%.	5905-101-9252	1
7. Variable transformer CN-16/U.	5950-235-2086	1
8. Power Supply PP-621/URR	Part of receiver	
9. Voltmeter IS-185, 0-150-vac, 60-cps, ±1.25%	3F7385	1
10. Electronic Equipment Maintenance Kit MK-288/URM.	6625-557-5716	1

#### 98. Test Setup

All tests will be performed under the conditions listed below. Testing will be simplified if connections and panel-control settings are made initially and changed only as required for the individual tests. For conducting the tests in an electrically noisy area, a screened room is mandatory.

*a.* Line voltage and frequency ..... 115 volts ac  
±5% at 60 cycles.

*b.* Warmup period ..... 3 hours.

*c.* Standard modulation..... 30% am. at  
400 cycles.

*d.* Audio load impedance..... 600 ohms.

*e.* For tests at 10 mc and higher, use Signal Generator AN/USM-44 (Hewlett-Packard Model 608D) instead of RF Signal Generator AN/URM-25D.

*f.* Dummy antenna for balanced input should be the DA-121/U, part of MK-288/URM.

*g.* Receiver chassis should be grounded during all testing procedures.

*h.* Front panel controls are as follows:

Control	Position
FUNCTION	As required.
ANT. TRIM	Adjust for maximum output.
BFO	OFF.
DIAL LOCK	Unlocked.
ZERO ADJ.	Unengaged.
LOCAL GAIN	As required.
RF GAIN	10 (maximum).
OVENS (back panel)	OFF.
BANDWIDTH	8.
LINE METER	OFF.
LINE GAIN	0.
AGC	MED.
LIMITER	OFF.
AUDIO RESPONSE	WIDE.
BFO PITCH	0.
BREAK IN	OFF.

## Section II. TESTS

### 99. Amplitude-Modulation Sensitivity Test

Set the front panel controls (para 98). Turn the FUNCTION switch to MGC. Make the amplitude-modulation (am.) sensitivity test at both ends and the center of each band. Use a 30 percent modulated 400-cps signal.

- Connect the signal generator to the BALANCED ANTENNA jack.
- Connect the ME-30A/U in parallel with a 600-ohm 1-watt resistor between LOCAL AUDIO terminals 6 and 7.
- Tune the signal generator and the receiver to the same frequency.
- Adjust the signal generator attenuator for the following output:

Band (mc)	Signal generator (microvolts)
0.5-16	4
16-32	5

- Adjust the LOCAL GAIN control to obtain a ME-30A/U indication of 2.45 volts.
- Turn the modulation off. The ME-30A/U indication should be not more than 0.77 volt.

### 100. Cw Sensitivity Test

Set the front panel controls (para 98). Turn the FUNCTION switch to MGC. Make the cw sensitivity test at any frequency.

- Connect the signal generator to the BALANCED ANTENNA jack.
- Connect the ME-30A/U in parallel with a 600-ohm 1-watt resistor between LOCAL AUDIO terminals 6 and 7.
- Tune the signal generator and the receiver to the same frequency.
- Adjust the signal generator attenuator for, the following output:

Band (mc)	Signal generator (microvolts)
0.5-16	1
16-32	1

- Turn the BFO switch to ON. control for approximately a 1,000-cycle tone.

f. Adjust the BFO PITCH control for approximately a 1,000-cycle tone.

g. Adjust the LOCAL GAIN control for an ME-30A/U indication of 2.45 volts.

h. Turn the BFO switch to OFF. The ME30A/U indication should be less than 0.77 volts.

### 101. Overall Selectivity Test

Set the front panel controls (para 98). Turn the FUNCTION switch to MGC.

- Connect the signal generator to the BALANCED ANTENNA jack.
- Connect the TS-505/U between DIODE LOAD terminal 14 and GND terminal 16.
- Tune the receiver to some frequency ending in an even 10 kc between 0.5 and 32 mc. Tune the signal generator to the same frequency. Adjust the signal generator attenuator for a 15-microvolt (uv) output.
- Turn the BFO PITCH control to 0.
- Turn the BFO switch to ON.
- Turn the BANDWIDTH switch to 1.
- Zero beat the signal generator with the receiver.
- Turn the BFO switch to OFF.
- Adjust the RF GAIN control to obtain a -50-volt indication on the TS-505/U.
- Detune the signal generator until the TS505/U indicates the same as in the *Specific standard* column. The deviation should be not more than that indicated in the deviation column.

BANDWIDTH switch	Specific standard (volts)	Deviation (not more than) (kc)
1	2.5	1.5
1	0.5	3.0
1	0.05	5.0
16	2.5	16.0
16	0.5	19.5
16	0.05	24.0

### 102. Overall Gain Test

Set the front panel controls (para 98). Turn the FUNCTION switch to MGC. Turn the DIAL LOCK and ZERO ADJ controls fully counterclockwise.

c. Connect the TS-505/U across DIODE LOAD terminal 14 and GND terminal 16, without removing the jumper wire from terminal 15.

d. Tune the signal generator and the receiver to 500 kc. Turn the BFO switch to ON, and zero beat the signal generator with the receiver.

e. Turn the BFO switch to OFF, and adjust the ANT. TRIM control for a maximum TS-505/U voltage indication.

f. Adjust the signal generator attenuator for a TS-505/U indication of -7 volts, and record the setting.

g. The signal generator output should indicate between 1 and 4 microvolts.

h. Perform procedures given in *d* through *g* above at both ends and the center of each of the following six coil ranges: 0.5-1, 1-2, 2-4, 4-8, 8-16, and 16-32 mc.

### 103. Maximum Audio Output Test

Set the front panel controls (para 98). Turn the FUNCTION switch to AGC.

a. Connect the signal generator to the BALANCED ANTENNA jack.

b. Connect the TS-505/U across DIODE LOAD terminal 14 and GND terminal 16.

c. Turn the BFO switch to ON. Tune the receiver to 1.5 mc.

e. Zero beat the signal generator with the receiver.

f. Turn the BFO switch to OFF.

g. Adjust the ANT. TRIM control for maximum TS-505/U voltage indication.

h. Connect the ME-30A/U, in parallel with a 600-ohm 1-watt resistor, between chassis ground and the test points listed in the chart below.

i. With a 10-uv, 400-cps, modulated 30 percent input, the required output is:

Test point	Specific (not less than)
LOCAL AUDIO	17.3 vac
LINE AUDIO	2.45 vac
PHONES	0.78 vac

### 104. Audio Harmonic Distortion Test

a. Connect the signal generator to the BALANCED ANTENNA jack. Adjust the signal

generator for a 1,000-uv, 30 percent modulated, 400-cps signal.

b. Turn the FUNCTION switch to AGC.

c. Tune the signal generator and receiver to 1.5 mc.

d. Connect the ME-30A/ U and the TS-723A/U. in parallel with a 600-ohm resistor, to the test points given in *f* and *g* below.

e. Adjust the LOCAL GAIN and LINE GAIN controls to produce the test audio voltage levels used in *f* and *g* below.

f. With 17.3 volts between LOCAL AUDIO terminals 6 and 7, the distortion, as indicated by the TS-723A/U, should not exceed 10 percent.

g. With 2.45 volts between LINE AUDIO terminals 10 and 13, the distortion, as indicated by the TS-723A/U should not exceed 6 percent.

### 105. Automatic Gain Control Test

Set the front panel controls (para 98). Turn the FUNCTION switch to AGC.

a. Connect the signal generator to the BALANCED ANTENNA jack. Connect the ME-30A/U to LOCAL AUDIO terminals 6 and 7.

b. Tune the signal generator to successive receiver settings of 1.5, 3.0, 6.0, 12.0, and 24.0 mc, modulating the output 30 percent at 400 cps.

c. With a 5-uv output from the signal generator, tuned to the frequencies given in *b* above, adjust the LOCAL GAIN control for 1.7 volts across the LOCAL AUDIO terminals.

d. With signal generator inputs of 1,000uv and 100,000 uv to the receiver, note the proportionate increases in audio output.

Speed generator output	Specific (not more than)
1, 000 uv	3.0 ac volts
100, 000 uv	5.4 ac volts

e. Adjust the signal generator output for a reading of 20 on the CARRIER LEVEL meter.

f. Increase the output of the signal generator in 20-db steps and note that the CARRIER LEVEL meter readings increase in steps of  $20 \pm 6$ .

g. Decrease the signal generator output 20 db below the setting given in *e* above, and note

that the CARRIER LEVEL meter indication will drop to between zero and 6.

### 106. Frequency Range Test

Frequency range of each band should be not less than the following:

Band	Frequency (mc)
0	0.5-1.0
1	1.0-2.0
2	2.0-3.0
3	3.0-4.0
4	4.0-5.0
5	5.0-6.0
6	6.0-7.0
7	7.0-8.0
8	8.0-9.0
9	9.0-10.0
10	10.0-11.0
11	11.0-12.0
12	12.0-13.0
13	13.0-14.0
14	14.0-15.0
15	15.0-16.0
16	16.0-17.0
17	17.0-18.0
18	18.0-19.0
19	19.0-20.0
20	20.0-21.0
21	21.0-22.0
22	22.0-23.0
23	23.0-24.0
24	24.0-25.0
25	25.0-26.0
26	26.0-27.0
27	27.0-28.0
28	28.0-29.0
29	29.0-30.0
30	30.0-31.0
31	31.0-32.0

### 107. Dial Calibration and Resetability Tests

*a. Resetability.* It should be possible to tune the receiver visually to any frequency to an accuracy within 300 cps when the indicating counter has been adjusted at the nearest 100-kc calibration point. In each case, minimize backlash error by tuning to the test frequency from the low frequency side. When the indicating counter has been adjusted at the low end of the range, error at the high end of the range should be within -1,500 to +200 cps.

*b. Dial Calibration (Kc).*

- (1) Connect the signal generator and the AN/USM-26 to the BALANCED ANTENNA jack.

- (2) Turn the MEGACYCLE CHANGE control for 01 on the frequency indicator.
- (3) Turn the KILOCYCLE CHANGE control to the 50-kc points between each of the 100-kc calibration points throughout the range of the KILOCYCLE CHANGE control.
- (4) At each of the frequencies listed in paragraph 106, zero beat the signal generator with the receiver.
- (5) The frequency as indicated on the AN/USM-26 should be within  $\pm 300$  cps of the receiver frequency indicator.

*c. Dial Calibration (Mc).*

- (1) Connect the AN/USM-26 to LOCAL AUDIO terminals 6 and 7.
- (2) Calibrate the receiver at 500 kc.
- (3) Without further adjustment of the BFO PITCH and KILOCYCLE CHANGE controls, turn the MEGACYCLE CHANGE control through each of its 32 positions.
- (4) At each position ((3) above, the frequency as indicated on the AN/USM-26 should be less than 4 kc between any two adjacent MEGACYCLE CHANGE positions.

### 108. BFO Test

Set the front controls (para 98). Turn the FUNCTION switch to MGC.

- a.* Connect the signal generator to the BALANCE ANTENNA jack.
- b.* Connect the AN/USM-26 to the IF OUTPUT jack.
- c.* Connect the headphones to the PHONES jack.
- d.* Turn the BFO PITCH control to 0. Zero beat the signal generator with the receiver. The frequency as indicated on the AN/USM-26 should be 455 kc.
- e.* Connect the AN/USM-26 to LOCAL AUDIO terminals 6 and 7.
- f.* Turn the BFO PITCH control to +3 and -3. The audio output frequency as indicated by the AN/USM-26 should be 3 kc  $\pm 600$  cps in both cases.

### 109. Calibration Oscillator Test

This adjustment requires the use of an extremely accurate frequency standard for de-

termining the reference frequency. Station WVVV from the Bureau of Standards at Washington, D. C. should be used as the frequency standard if it is at all possible to receive signals from this station. Station WWV operates on 2.5, 6, 10, 15, and 20 mc. Use the highest frequency signal that can be reliably received by the receiver.

- a. Tune in the highest frequency signal from WVVV that can be received reliably.
- b. Turn the BANDWIDTH switch to 1.
- c. Tune the receiver to exact resonance by adjusting the KILOCYCLE CHANGE and ANT. TRIM controls for a maximum CARRIER LEVEL meter indication.
- d. Turn the LINE METER switch to -10, and adjust the LINE GAIN control for a half-scale LINE LEVEL meter indication.
- e. Turn the BFO switch to ON, and adjust the BFO PITCH control to exact zero beat with WWV (during nontone periods). This will be when the LINE LEVEL meter indication drops to zero and fluctuates at a slow rate.
- f. Turn the FUNCTION' switch to CAL.
- g. If necessary, adjust (FREQ ADJ) capacitor C901 (fig. 33) for zero beat (a minimum LINE LEVEL meter indication).

### 110. Squelch Threshold Test

Set the front panel controls (para 98). Turn the FUNCTION switch to SQUELCH.

- a. Apply a modulated 10-uv signal to the receiver.
- b. Determine the pull-in and dropout thresholds, by noting the disappearance and presence of audio output as the RF GAIN control is rotated from 0 to 10.
- c. Set the RF GAIN control to 10. Pin K of REMOTE CONTROL J105 on the rear panel of the receiver will be grounded.
- d. Set the BREAK IN switch to ON. Check to see that pin K of REMOTE CONTROL J105 is ungrounded.

### 111. Line Level Meter Test

Set the front panel controls (para 98). Turn the FUNCTION switch to AGC.

- a. Connect the AN/URM-25D to the BALANCED ANTENNA jack.

- b. Tune the AN/URM-25D and the receiver to 1,500 kc.
- c. Adjust the AN/URM-25D for a 1,000 uv signal, modulated 30 percent at 1,000 cps.
- d. Connect the ME-30A/U, in parallel with a 600-ohm 1-watt resistor, between LINE AUDIO terminals 10 and 13.
- e. Turn the LINE METER switch to 0.
- f. Adjust the LINE GAIN control for a LINE LEVEL meter indication at the VU mark.
- g. The audio output voltage as indicated on the ME-30A/U should be 0.77 volt  $\pm 5$  percent.

### 112. If. Output Test

Set the front panel controls (para 98). Turn the FUNCTION switch to MGC.

- a. Connect the signal generator to the BALANCED ANTENNA jack.
- b. Tune the signal generator and the receiver to 1.5 mc.
- c. Turn the BFO switch to ON.
- d. Set the signal generator for a 3-microvolt output.
- e. Connect headphones to the PHONES jack.
- f. Zero beat the signal with the receiver.
- g. Turn the BFO switch to OFF.
- h. Connect the TS-505/U between DIODE LOAD terminal 14 and GND terminal 16.
- i. Adjust the ANT. TRIM control for maximum voltage indication on the TS-505/U.
- j. Connect the ME-30A/U, in parallel with a 60-ohm 1-watt resistor, between J106 IF OUTPUT 50 OHM jack and chassis ground.
- k. Adjust the OF GAIN control to obtain a 20-millivolt indication on the ME-30A/U.
- l. The if. output voltage as indicated by the ME-30A/U should be:

Input (microvolts)	Output (millivolts)
6	40 $\pm 10\%$
15	100 $\pm 10\%$
30	200 $\pm 10\%$

### 113. Limiter Clipping Level Test

Set the front panel control (para 98). Turn the FUNCTION switch to AGC.

- a. Connect the AN/URM-25D to the BALANCED ANTENNA jack.
- b. Tune the AN/URM-25D and the receiver to 1,500 kc.
- c. Adjust the AN/URM-25D output to 1,000 uv modulated 50 percent at 400 cps.
- d. Adjust the LINK GAIN control for a LINE LEVEL indication at the VU mark.
- e. Slowly turn the LIMITER control from OFF to 10.
- f. As the LIMITER control is advanced from OFF to 10, the LINE LEVEL meter indication may drop 1 db, return to the VU mark, and then smoothly and gradually move to the left.

#### 114. Antenna Relay Grounding Test

Set the front panel controls (para 98). Turn the FUNCTION switch to AGC, and BFO switch to ON.

- a. Connect the AN/USM-44 to the BALANCED ANTENNA jack.
- b. Zero beat the AN/USM-44 with the receiver at 30.05 mc.
- c. Turn the BFO switch to OFF.
- d. Connect the TS-505/U to DIODE LOAD terminal 14 and GND terminal 16.
- e. Adjust the ANT. TRIM control for a maximum TS-505/U indication.
- f. Adjust the AN/USM-44 output voltage for a TS-505/U indication of -5 volts. Note the AN/USM-44 output voltage.
- g. Turn the FUNCTION switch to CAL.
- h. Increase the AN/USM-44 output voltage until the TS-505/U indication is again -5 volts. Note the AN/USM-44 output voltage.
- i. The AN/USM-44 output voltage noted in *h* above should be at least 300 times the output voltage noted in *f* above.

#### 115. Antenna Balance Ratio Test

Set the front panel controls (para 98). Turn the FUNCTION switch to MGC.

- a. Set the receiver frequency dial to 00 +000.
- b. Connect the output of the signal generator between chassis ground and the junction of two 62-ohm resistors. Connect the free end of each resistor to each BALANCED ANTENNA terminal.
- c. Tune the signal generator to the receiver frequency.
- d. Connect the TS-505/U between DIODE LOAD terminal 14 and GND terminal 16.
- e. Adjust the signal generator output for a -7-volt TS-505/U indication. Note the output of the signal generator.
- f. Disconnect the two 62-ohm resistors, and connect the signal generator direct to the BALANCED ANTENNA jack. Repeat the procedure given in *e* above, and note the signal generator output.
- g. Repeat the procedures given in *e* and *f* above for the following frequency indicator dial settings. The voltages noted in *e* above should exceed those noted in *f* above by at least the following ratio:

Dial reading	Ratio
00 +000	178
01 +000	100
03 +000	100
07 +000	56
15 +000	31
31 +000	10

#### 116. Operational Checks

- a. Meters should operate satisfactorily.
- b. All controls should operate smoothly.
- c. Quality of signals should be excellent.
- d. Frequency indicator should function properly.
- e. Vibration effects should be negligible.

## APPENDIX REFERENCES

---

DA Pamphlet 310-4	Index of Technical Manuals, Technical Bulletins, Supply Bulletins, Lubrication Orders, and Modification Work Orders.
MWO SIG 11-5820-294-35/1	Modification of Radio Receivers R-389/URR, R-390/URR and R-391/URR to Provide More Adequate Fusing.
TA 11-17	Signal Field Maintenance Shops
TA 11-100 (11-17)	Allowances of Signal Corps Expendable Supplies for Signal Field Maintenance Shops.
TB SIG 319	Electronic Equipment Maintenance Kit MK-288/URM.
TM 11-1214	Instruction Book for Oscilloscope OS-8/U.
TM 11-2684A	Audio Oscillators TS-382A/U, TS-382B/U, TS-382D/U, and TS-382E/U.
TM 11-5017	Output Meters TS-585A/U, TS-585B/U, TS-585C/U, and TS-585D/U.
TM 11-5097	Spectrum Analyzers TS-723A/U, TS-723B/U, and TS-723C/U.
TM 11-5132	Voltmeter, Meter ME-30A/U and Voltmeters, Electronic ME-30B/U and ME-30C/U.
TM 11-5511	Electronic Multimeter TS-505/U.
TM 11-5527	Multimeters TS-352/U, TS-352A/U, and TS-352B/U.
TM 11-5551	Instruction Book for R-f Signal Generator Set AN/ URM-25.
TM 11-5551D	R. F. Signal Generator Set AN/URM-25D.
TM 11-5551E	R. F. Signal Generator AN/URM-25F.
TM 11-5820-259-35P	Field and Depot Maintenance Repair Parts and Special Tools List: Power Supply PP-621/URR.
TM 11-5820-357-10	Operator's Manual: Radio Receiver R-390/URR.
TM 11-5820-357-20	Organizational Maintenance Manual: Radio Receiver R-390/URR.
TM 11-5820-357-20P	Organizational Maintenance Repair Parts and Special Tools Lists and Maintenance Allocation Chart: Receiver, Radio R-390/URR.
TM 11-5820-357-35P	Field and Depot Maintenance Repair Parts and Special Tools List: Radio Receiver, R-390/URR
TM 11-5820-359-12P	Operator and Organizational Maintenance Repair Parts and Special Tools List and Maintenance Allocation Chart: Power Supply PP-621/URR.
TM 11-6625-239-12	Operation and Organizational Maintenance Manual: Electronic Multimeters TS-505A/U and TS-505B/U and Multimeters TS-505C/U and TS-505D/U.
TM 11-6625-274-12	Operator's and Organizational Maintenance Manual: Test Sets, Electron Tube TV-7/U, TV-7A/U, TV-7B/U, and TV-7D/U.

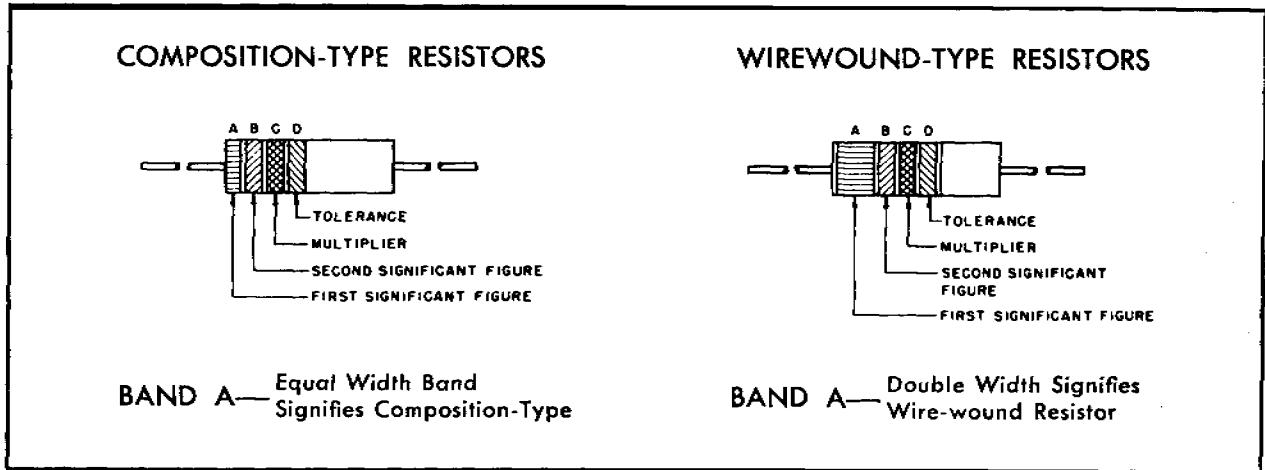

**COLOR CODE TABLE**

BAND A		BAND B		BAND C		BAND D*	
COLOR	FIRST SIGNIFICANT FIGURE	COLOR	SECOND SIGNIFICANT FIGURE	COLOR	MULTIPLIER	COLOR	RESISTANCE TOLERANCE (PERCENT)
BLACK	0	BLACK	0	BLACK	1		
BROWN	1	BROWN	1	BROWN	10		
RED	2	RED	2	RED	100		
ORANGE	3	ORANGE	3	ORANGE	1,000		
YELLOW	4	YELLOW	4	YELLOW	10,000	SILVER	± 10
GREEN	5	GREEN	5	GREEN	100,000	GOLD	± 5
BLUE	6	BLUE	6	BLUE	1,000,000		
PURPLE (VIOLET)	7	PURPLE (VIOLET)	7				
GRAY	8	GRAY	8	SILVER	0.01		
WHITE	9	WHITE	9	GOLD	0.1		

**EXAMPLES OF COLOR**

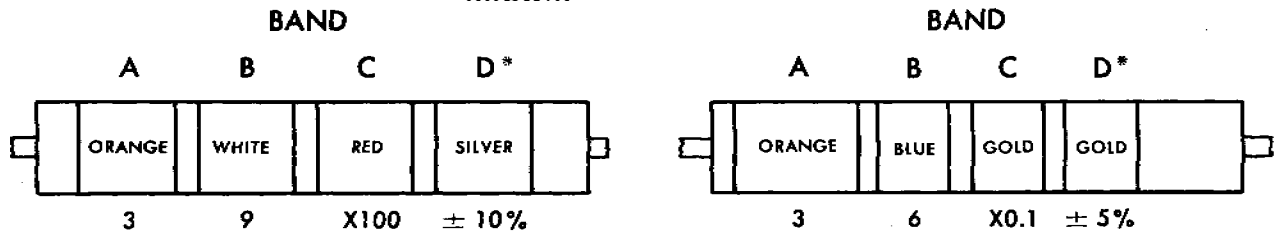

NOMINAL RESISTANCE      3,900 Ohms  
RESISTANCE TOLERANCE      ± 10 percent

3.6 Ohms  
± 5 percent

*Figure 54. MIL-STD resistor color code markings.*

STD-R2

COLOR CODE MARKING FOR MILITARY STANDARD CAPACITORS

GROUP I Capacitors, Fixed, Various-Dielectrics, Styles CM, CN, CY, and CB

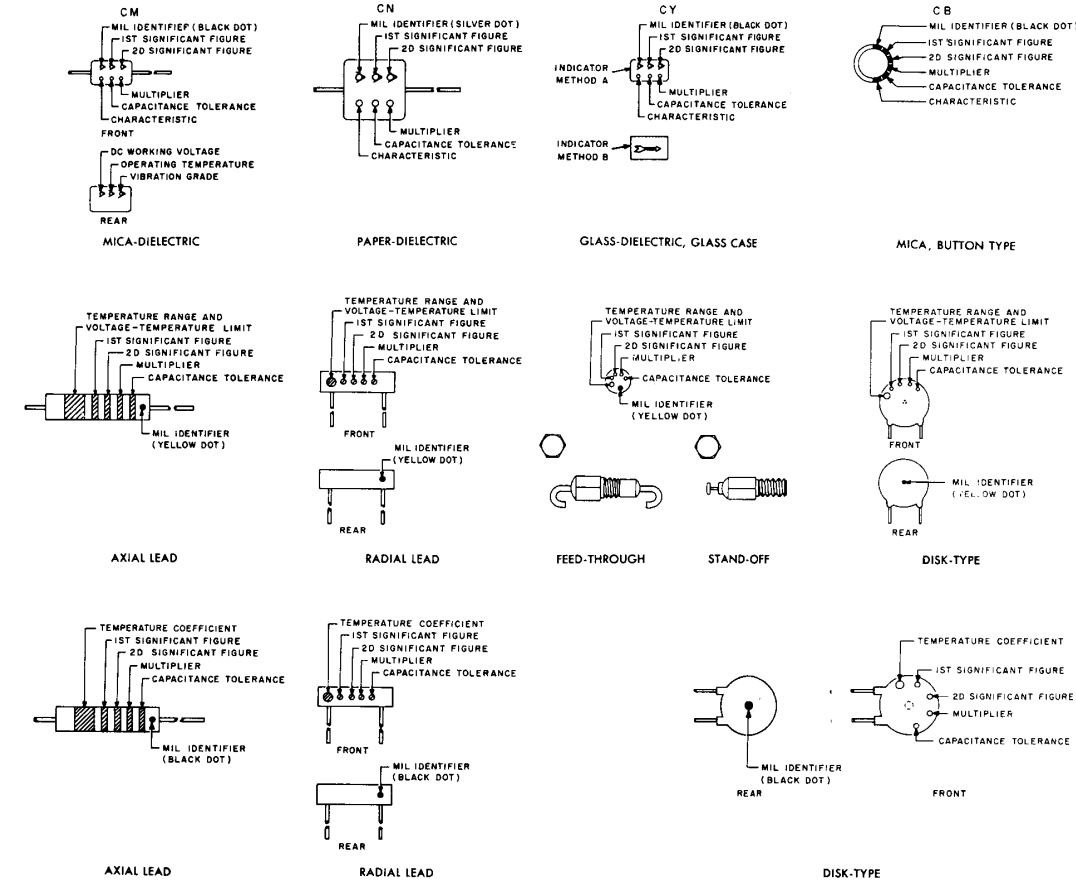

TABLE I-For use with Group I, Styles CM, CN,

COLOR	MIL ID	1st SIG FIG	2nd SIG FIG	MULTIPLIER <sup>1</sup>	CAPACITANCE TOLERANCE				CHARACTERISTIC <sup>2</sup>				DC WORKING VOLTAGE	OPERATING TEMP. RANGE	VIBRATION GRADE
					CM	CN	CY	CB	CM	CN	CY	CB			
BLACK	CM, CY, CB	0	0	1			± 20%	± 20%		A				-55° to +70°C	10-55 cps
BROWN		1	1	10					B	E		B			
RED		2	2	100	± 2%		± 2%	± 2%	C		C			-55° to +85°C	
ORANGE		3	3	1,000		± 30%			D		D	300			
YELLOW		4	4	10,000					E					-55° to +125°C	10-2,000 cps
GREEN		5	5		± 5%				F			500			
BLUE		6	6											-55° to +150°C	
PURPLE (VIOLET)		7	7												
GREY		8	8												
WHITE		9	9												
GOLD				0.1			± 5%	± 5%							
SILVER	CN				± 10%	± 10%	± 10%	± 10%							

TABLE II-For use with Group II, General

COLOR	TEMP. RANGE AND VOLTAGE - TEMP. LIMITS <sup>3</sup>	1st SIG FIG	2nd SIG FIG	MULTIPLIER <sup>1</sup>	CAPACITANCE TOLERANCE	MIL ID	COLOR	TEMPERATURE COEFFICIENT <sup>4</sup>	1st SIG FIG	2nd SIG FIG	MULTIPLIER <sup>1</sup>	CAPACITANCE TOLERANCE		MIL ID
												Capacitances over 10uuf	Capacitances 10uuf or less	
BLACK		0	0	1	± 20%		BLACK	0	0	0	1	± 1%	± 2.0uuf	CC
BROWN	AW	1	1	10	± 10%		BROWN	-30	1	1	10	± 1%		
RED	AX	2	2	100			RED	-80	2	2	100	± 2%	± 0.25uuf	
ORANGE	BX	3	3	1,000			ORANGE	-150	3	3	1,000			
YELLOW	AY	4	4	10,000		CK	YELLOW	-220	4	4				
GREEN	CZ	5	5				GREEN	-330	5	5		± 5%	± 0.5uuf	
BLUE	BV	6	6				BLUE	-470	6	6				
PURPLE (VIOLET)		7	7				PURPLE (VIOLET)	-750	7	7				
GREY		8	8				GREY		8	8	0.01			
WHITE		9	9				WHITE		9	9	0.1	± 10%		
GOLD							GOLD	-100					± 1.0uuf	
SILVER							SILVER							

1. The multiplier is the number by which the two significant (SIG) figures are multiplied to obtain the capacitance in uuf.
2. Letters indicate the Characteristics designated in applicable specifications: MIL-C-5, MIL-C-11272, and MIL-C-10950 respectively.
3. Temperatures coefficient in parts per million per degree centigrade.

Figure 55. MIL-STD capacitor color code markings.

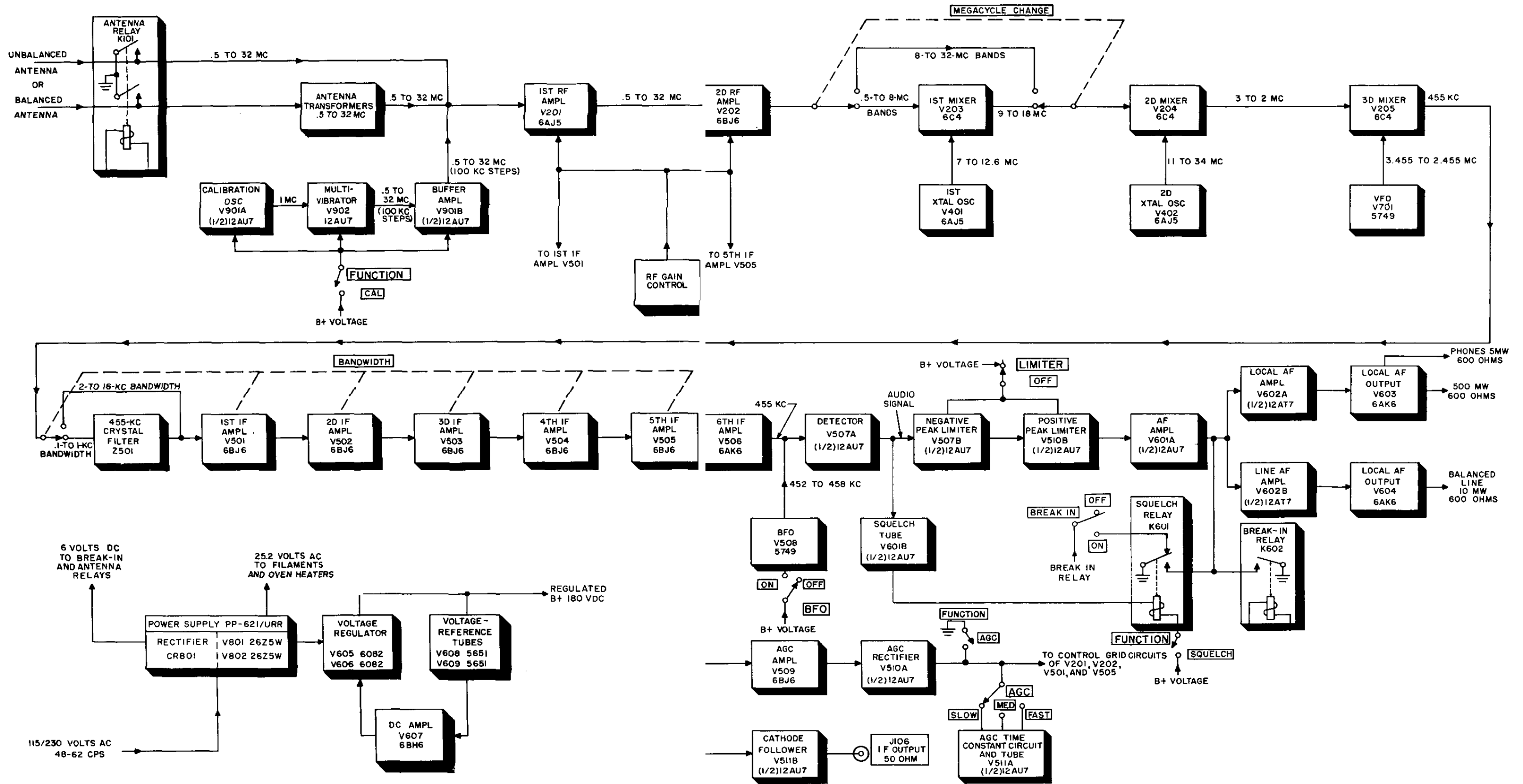

Figure 56. Radio Receiver R-390/URR, block diagram.

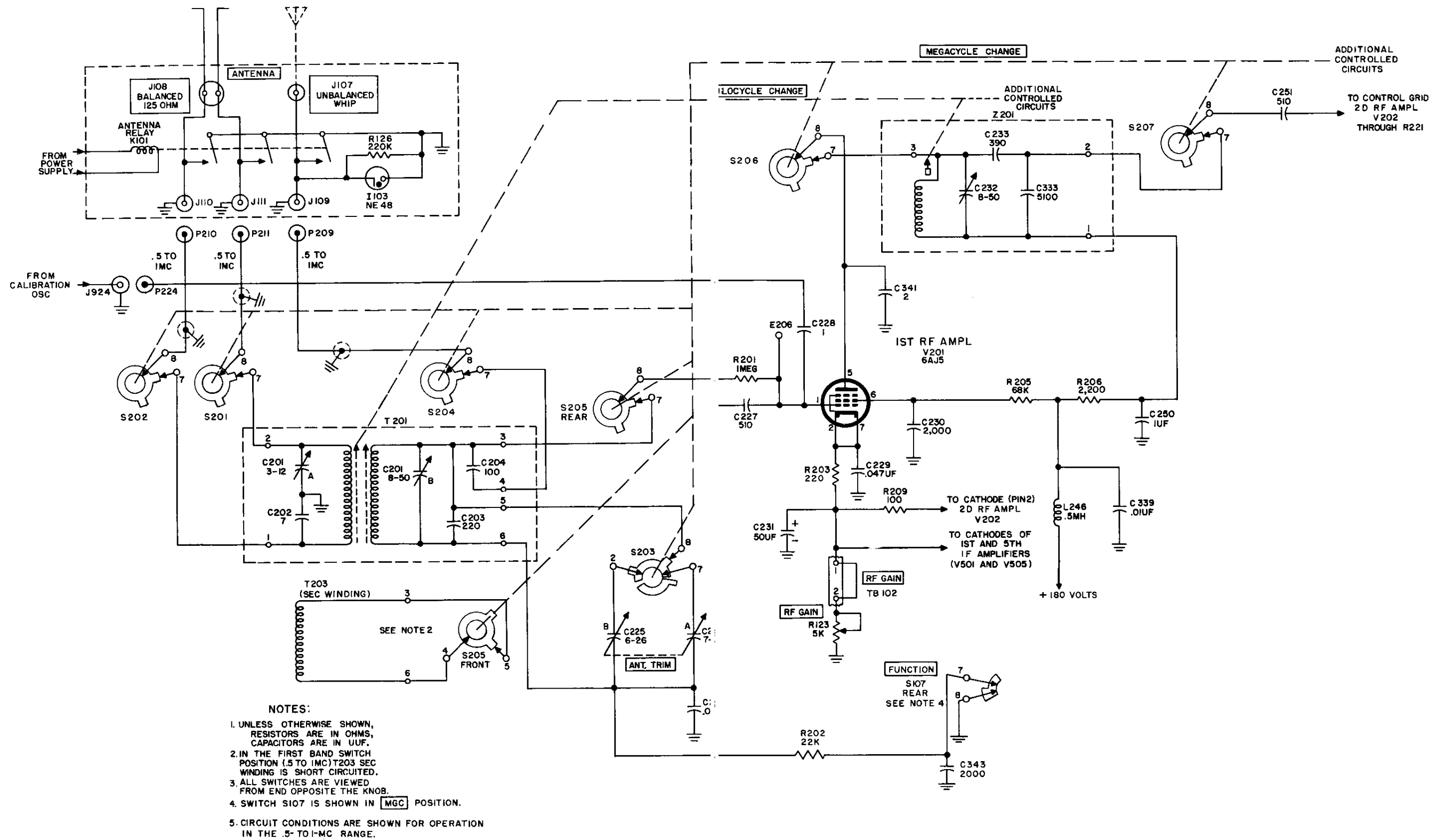

Figure 57. Antenna circuit and first rf amplifier, simplified schematic diagram.

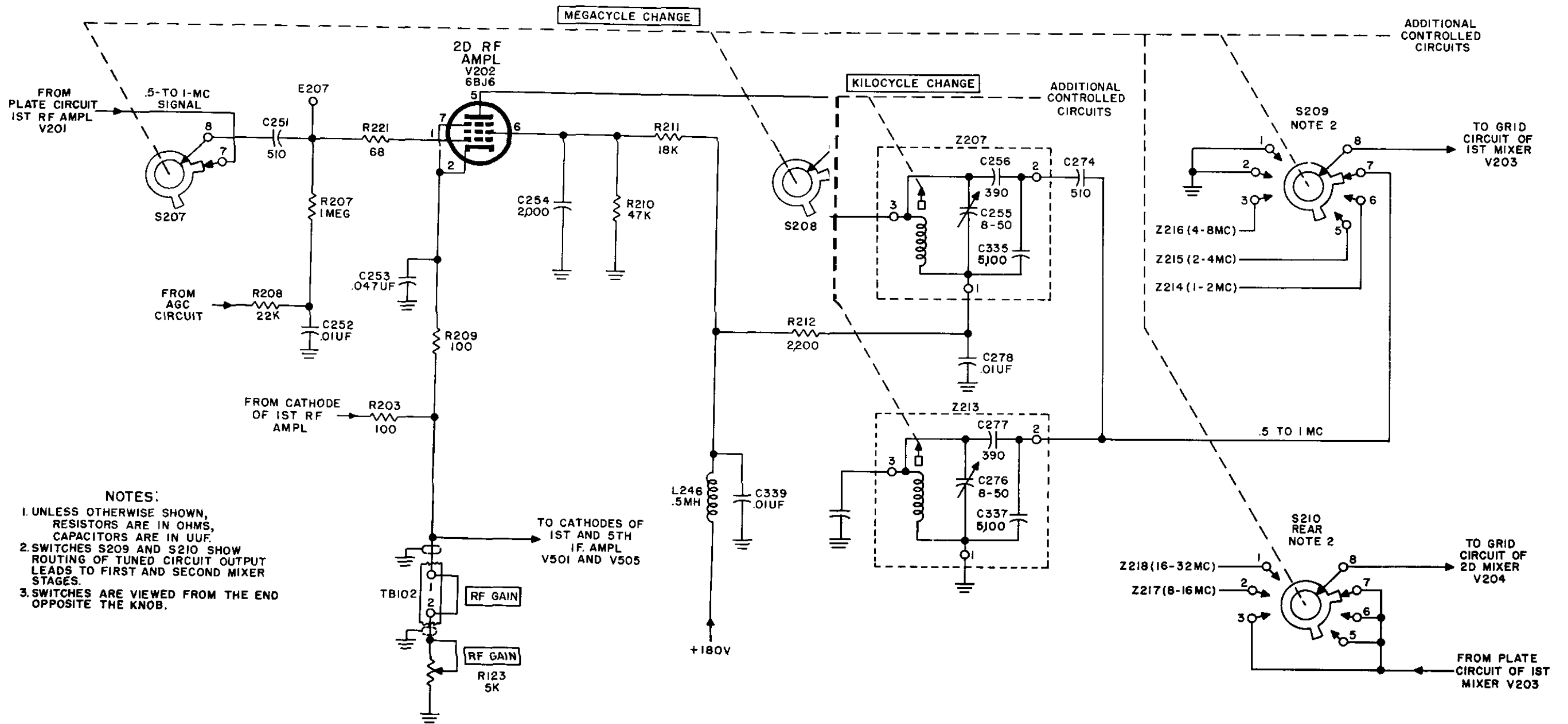

Figure 58. Second rf amplifier, simplified schematic diagram.



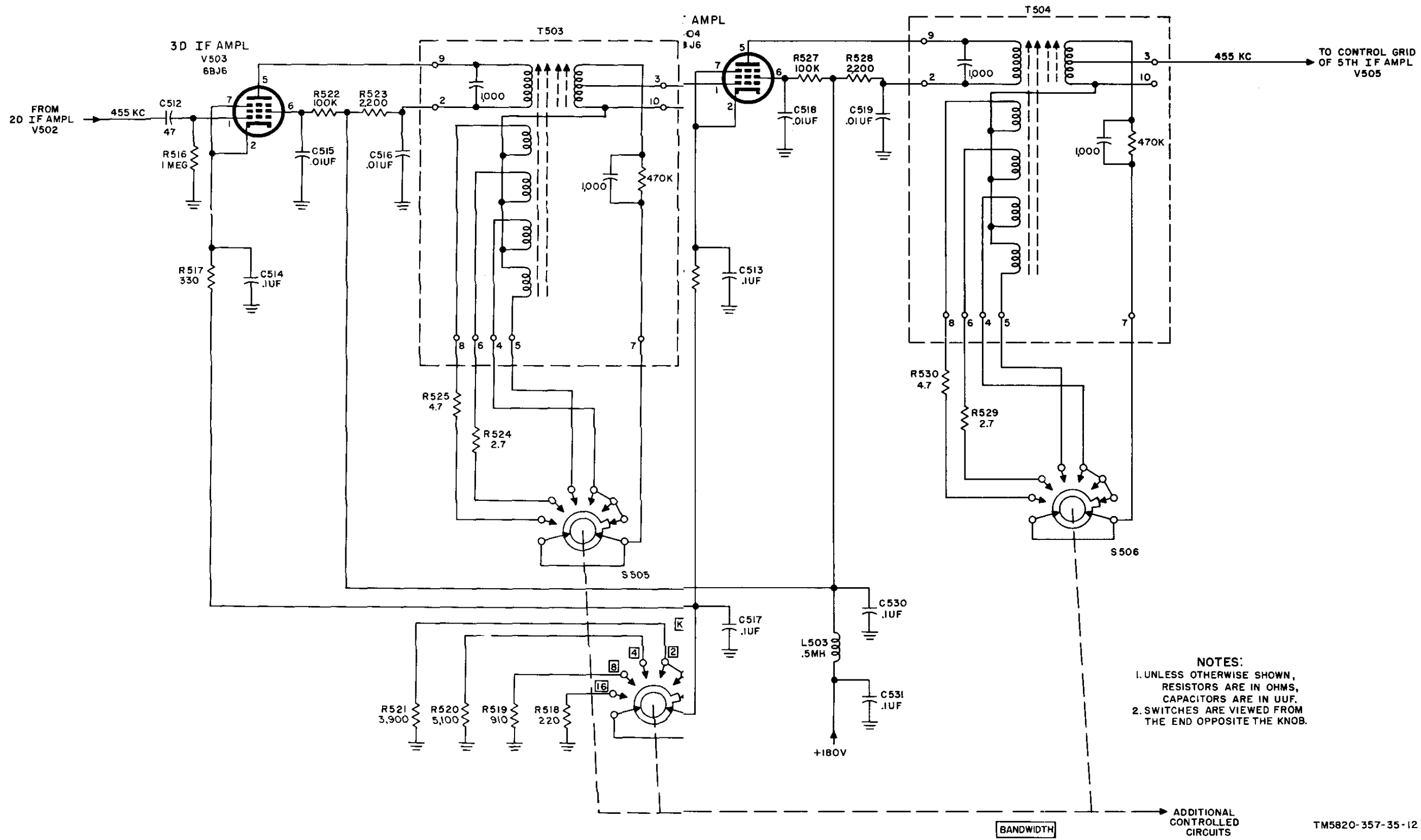

Figure 60. Third and fourth if. amplifiers, simplified schematic diagram.

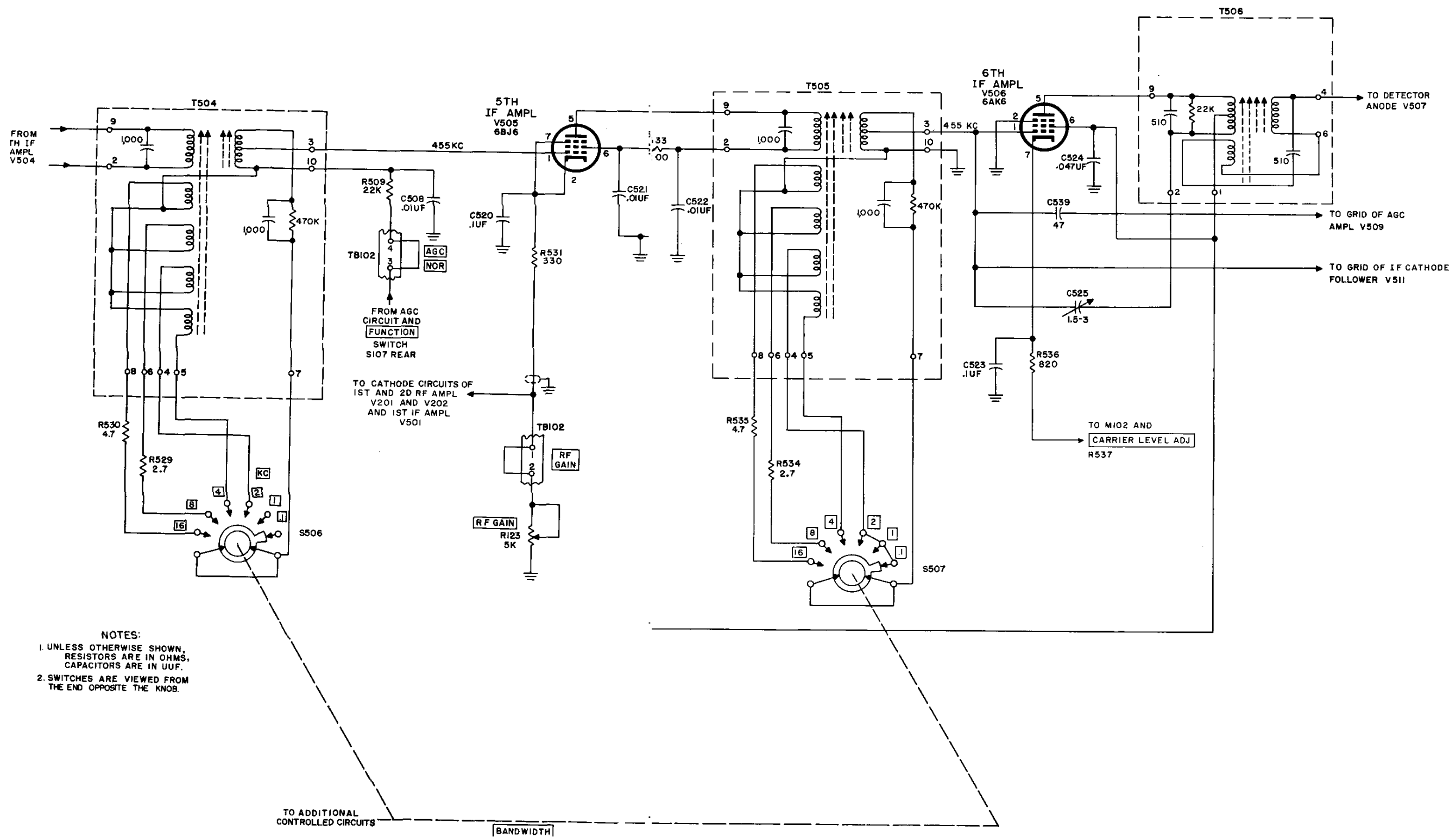

Figure 61. Fifth and sixth if. amplifiers, simplified schematic diagram.

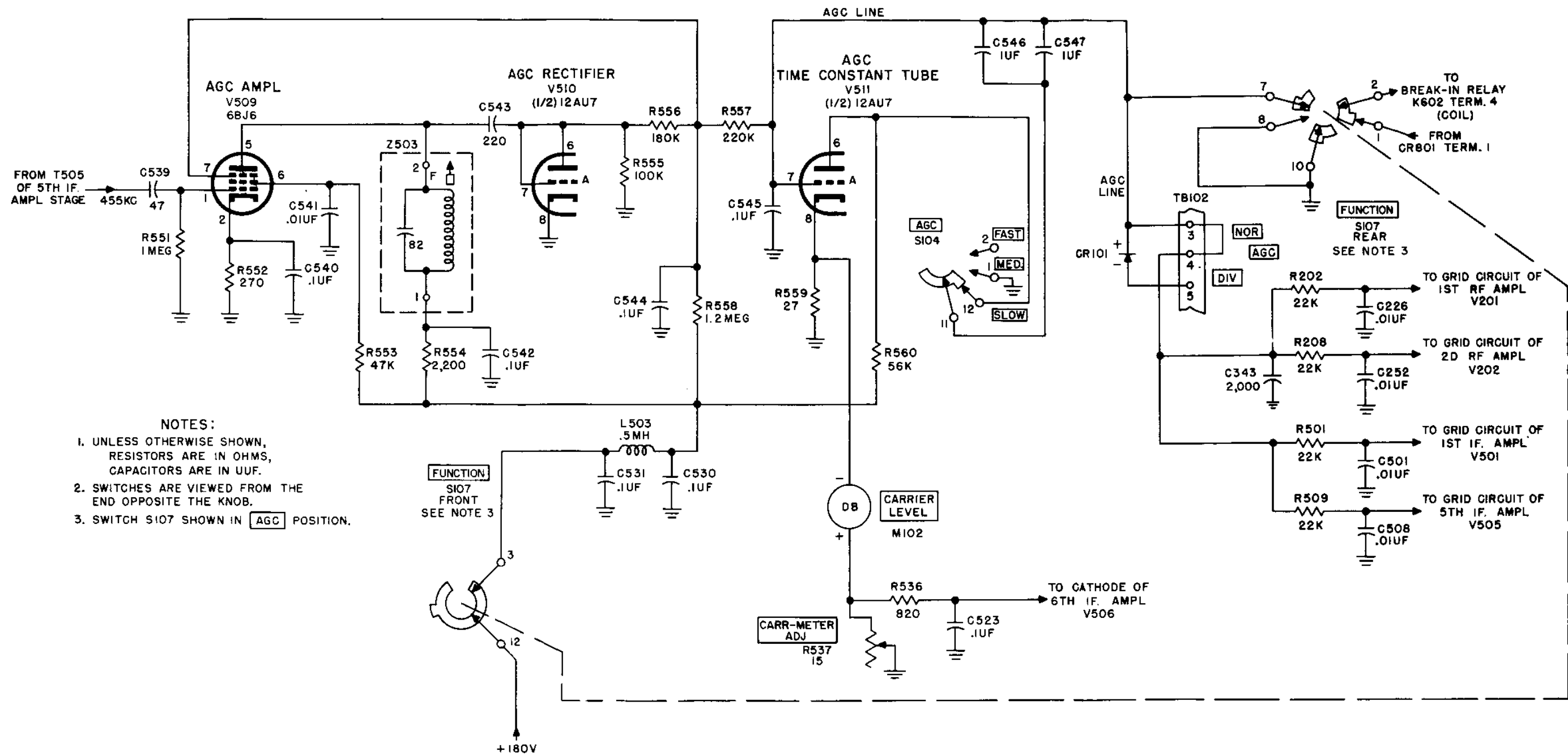

Figure 62. Agc circuits, simplified schematic diagram.



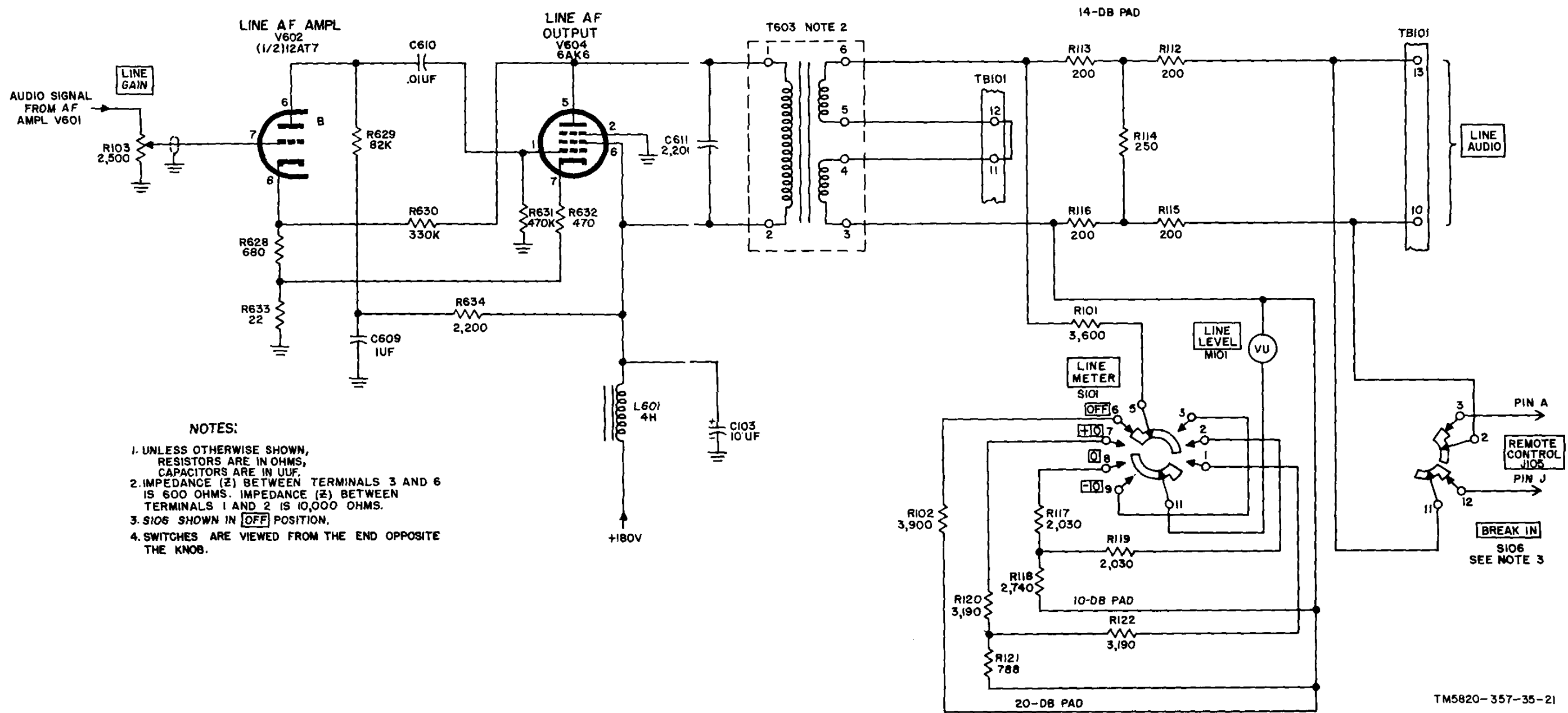
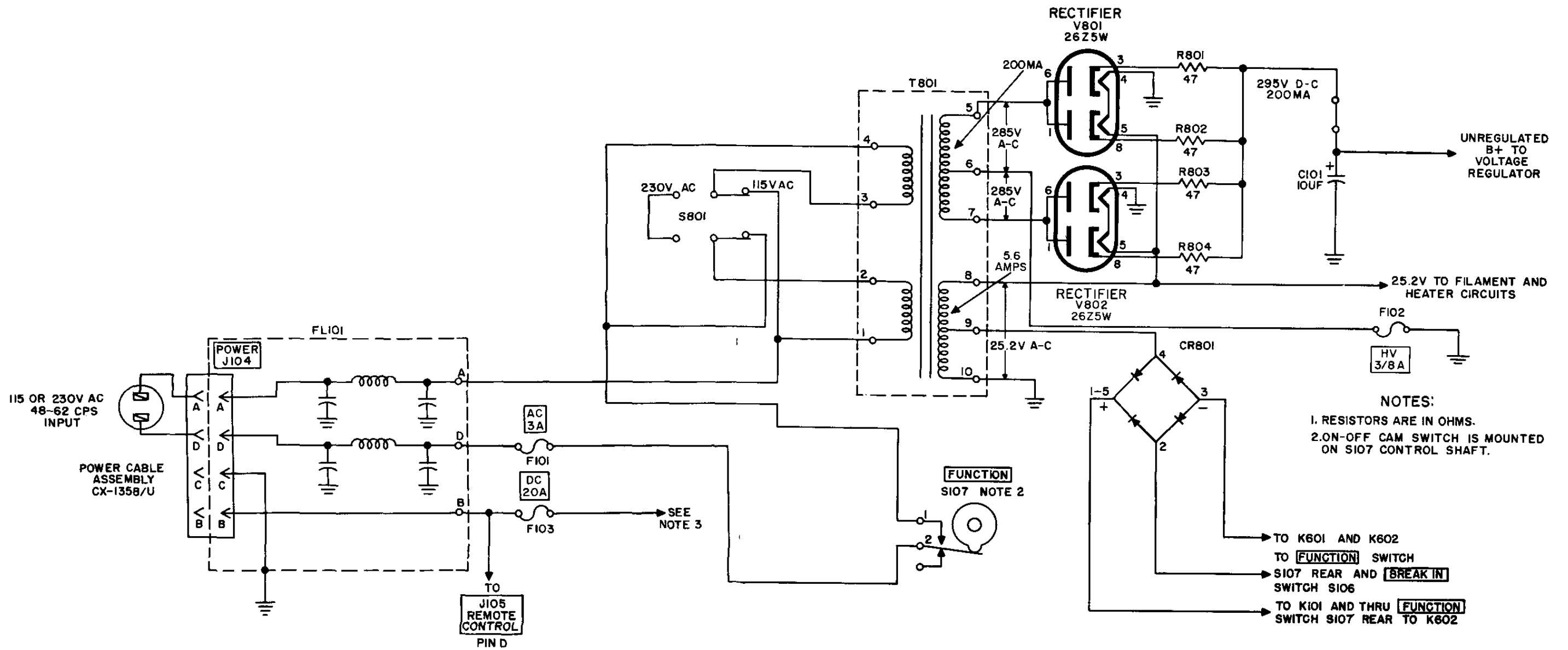

Figure 64. Line audio channel, simplified schematic diagram.



TM5820-357-35-26

Figure 65. Power Supply PP-621/URR, simplified schematic diagram.

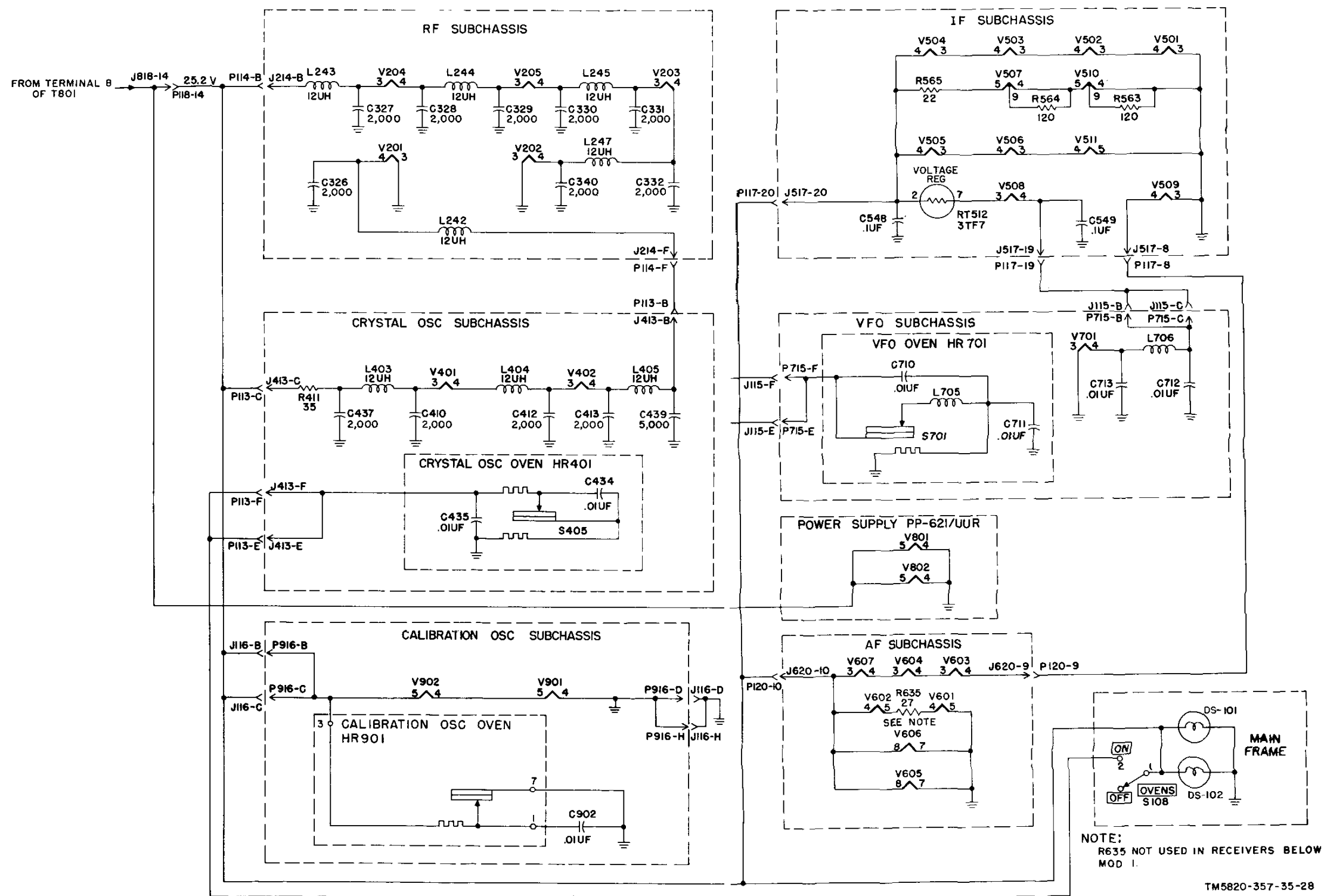
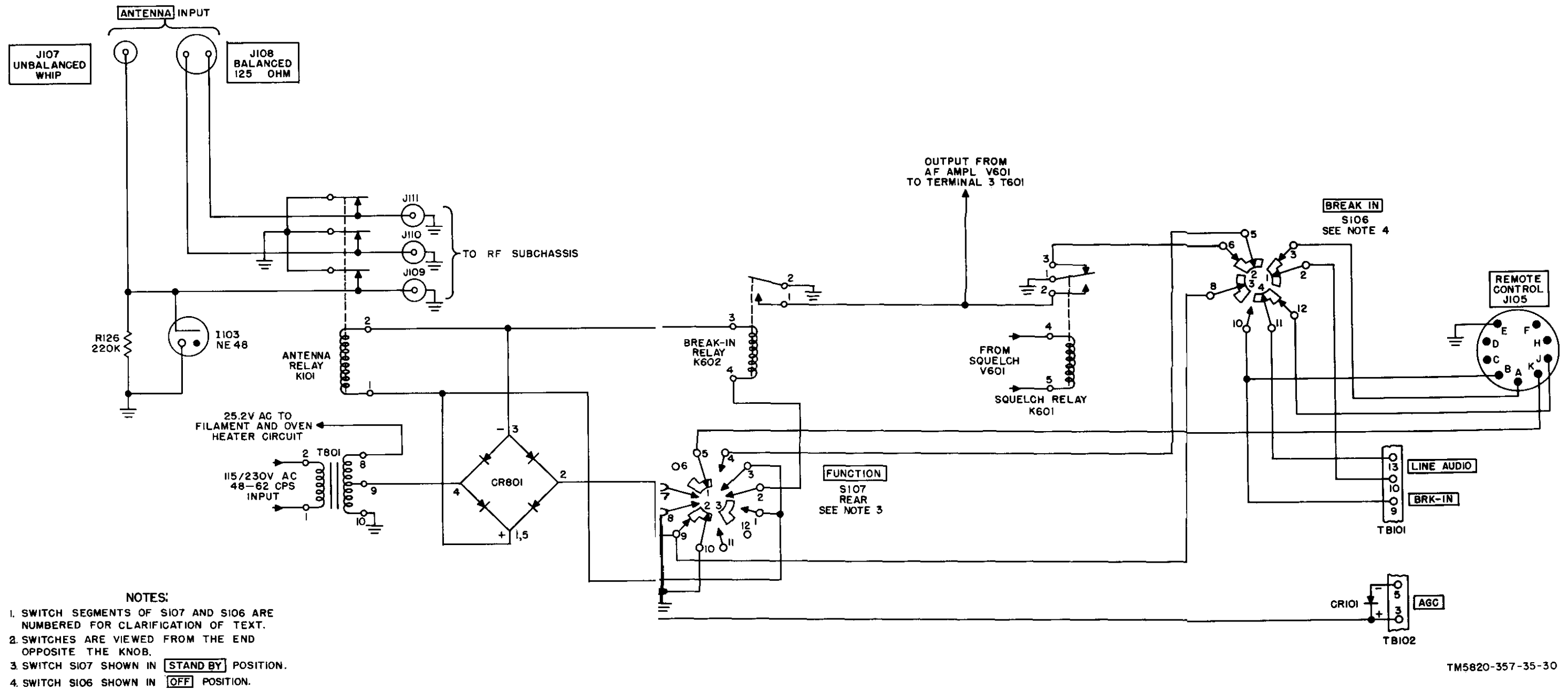

Figure 66. Filament and oven-heater circuits, simplified schematic diagram.



TM5820-357-35-30

Figure 67. Break-in circuit, simplifies schematic diagram.

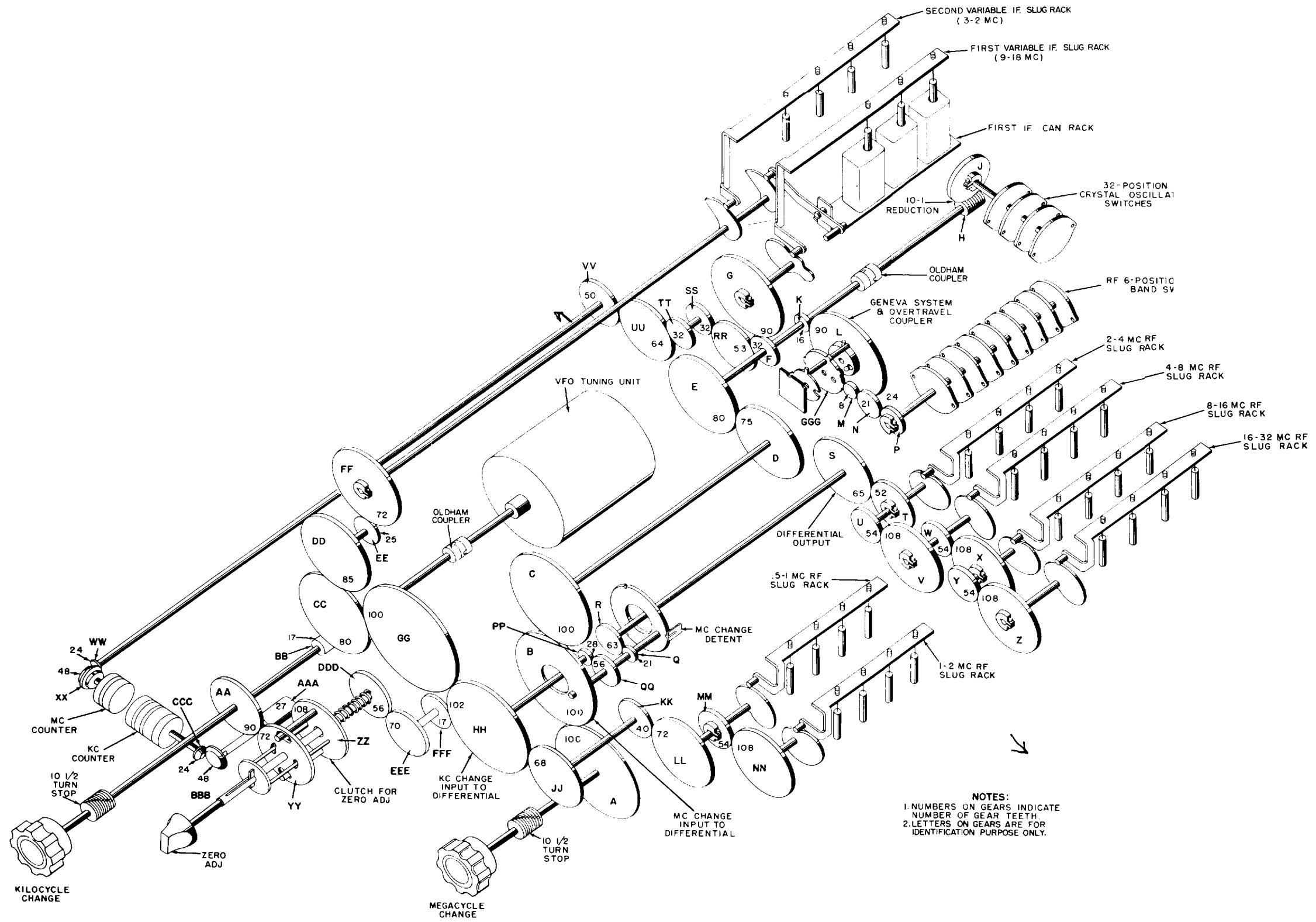
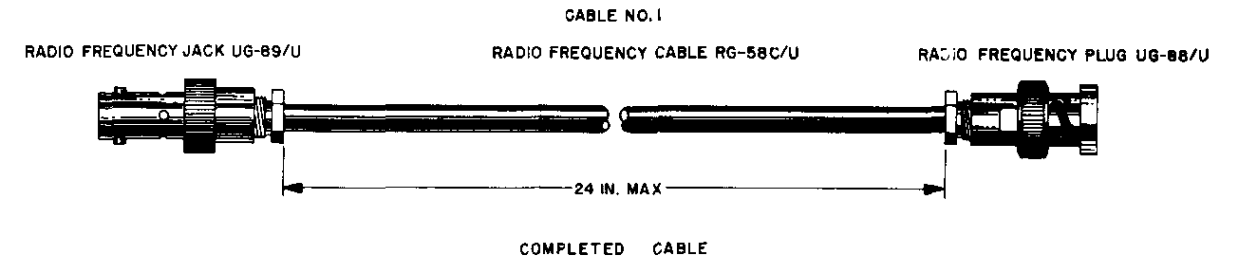

Figure 68. Tuning system, simplified diagram.



ASSEMBLING RADIO FREQUENCY JACK UG-89/U		NUT	SLEEVE	FEMALE CONTACT	JACK BODY
STEP 1		CUT END OF CABLE EVEN.			
STEP 2		REMOVE OUTER JACKET 1/2" - DON'T NICK BRAID.			
STEP 3		PUSH BRAID BACK, AND REMOVE 1/8" OF INSULATION AND CONDUCTOR.			
STEP 4		TAPER BRAID.			
STEP 5		SLIDE SLEEVE OVER TAPERED BRAID. FIT INNER SHOULDER OF SLEEVE SQUARELY AGAINST END OF JACKET.			
STEP 6		WITH SLEEVE IN PLACE, COMB OUT BRAID, FOLD BACK SMOOTH AS SHOWN, AND TRIM 3/32".			
STEP 7		BARE CENTER CONDUCTOR 1/8" - DON'T NICK CONDUCTOR.			
STEP 8		TIN CENTER CONDUCTOR OF CABLE. SLIP FEMALE CONTACT IN PLACE AND SOLDER. REMOVE EXCESS SOLDER. BE SURE CABLE DIELECTRIC IS NOT HEATED EXCESSIVELY AND SWOLLEN SO AS TO PREVENT DIELECTRIC ENTERING BODY.			
STEP 9		PUSH INTO BODY AS FAR AS IT WILL GO. SLIDE NUT INTO BODY AND SCREW INTO PLACE, WITH WRENCH, UNTIL MODERATELY TIGHT. HOLD CABLE AND SHELL RIGIDLY AND ROTATE NUT.			
STEP 10		ASSEMBLED CONNECTOR.			

Figure 69. Assembly instructions for extension cable No. 1.

**NOTES:**

1. THE MULTI-CONDUCTOR EXTENSION CABLES ARE TO BE FABRICATED OF NO. 18 TO 22 GAGE SHIELDED, STRANDED WIRE FOR AUDIO CONDUCTORS INDICATED BY  $\odot$ , NO. 18 GAGE STRANDED WIRE FOR CONDUCTORS MARKED  $\circ$ , AND NO. 22 GAGE STRANDED WIRE FOR ALL OTHER CONDUCTORS. INSULATION MUST BE RATED AT 600V.
2. CONNECTORS SHOWN VIEWED FROM REAR. COVERS TO BE USED WITH FEMALE CONNECTORS. AMPHENOL 86-834 COVER USED WITH 26-192 CONNECTOR.
3. CABLES TO BE LACED WITH NO. 6 VINYLITE LACING CORD AS SHOWN IN INSERT.
4. MAXIMUM LENGTH OF ALL CABLES IS 24 IN.
5. CHECK CONTINUITY AFTER COMPLETING FABRICATION.
6. LABEL EXTENSION CABLES FOR IDENTIFICATION.
7. NORMALLY, ONE EACH OF EXTENSION CABLES IS REQUIRED. IF VFO AND CALIBRATION OSC SUBCHASSIS ARE OPERATED OUTSIDE RECEIVER AT SAME TIME, TWO NO. 7 CABLES ARE NEEDED.

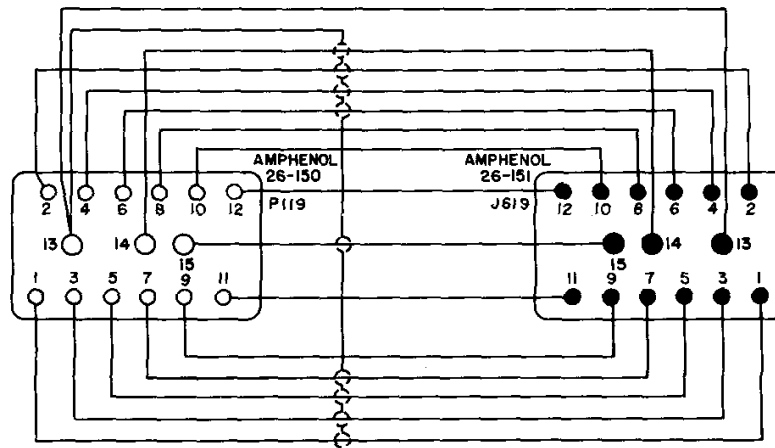
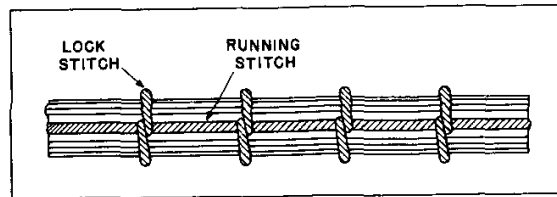

CABLE NO.3

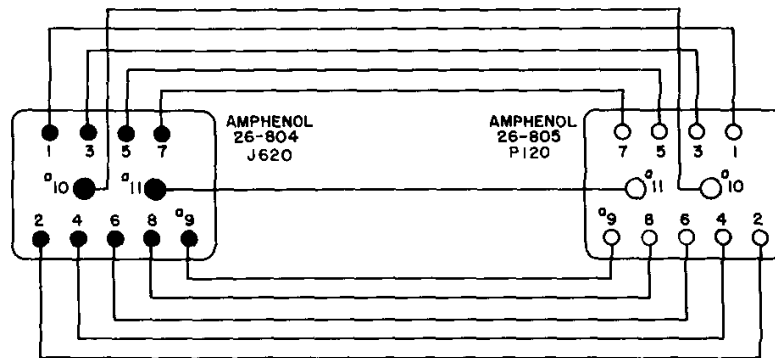

CABLE NO.4

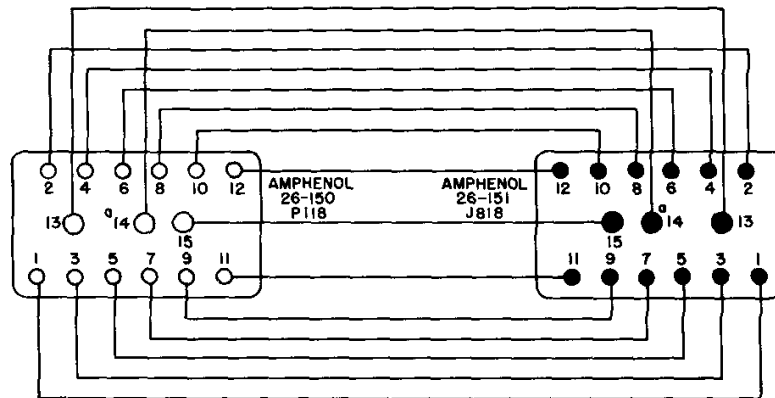

CABLE NO.5

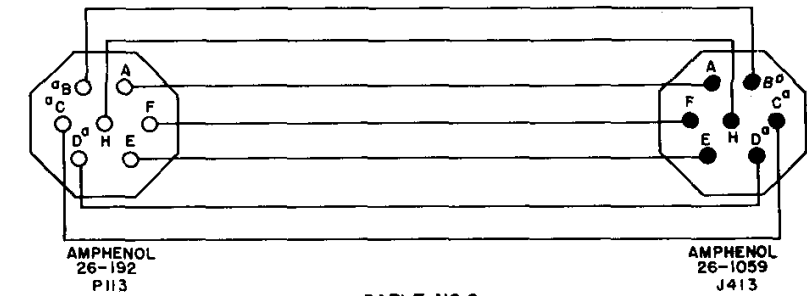

CABLE NO.6

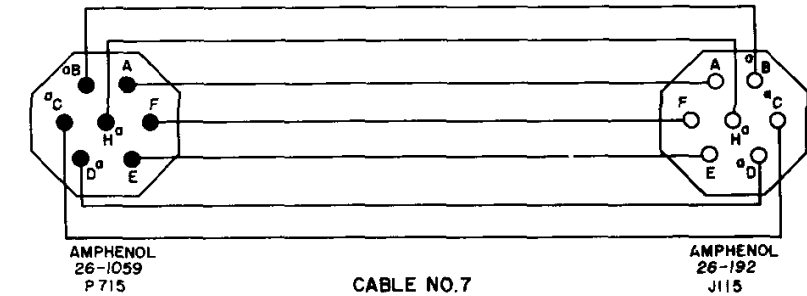

CABLE NO.7

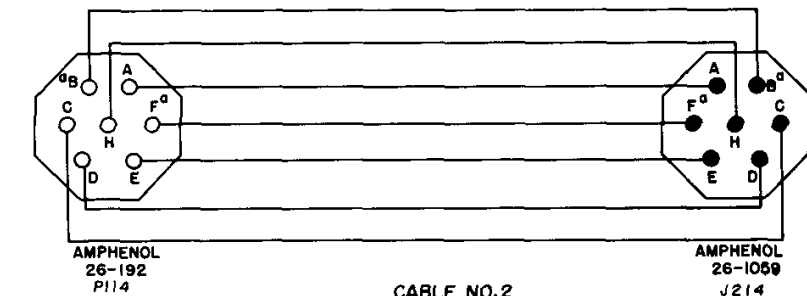

CABLE NO.2

TM5820-357-35-34

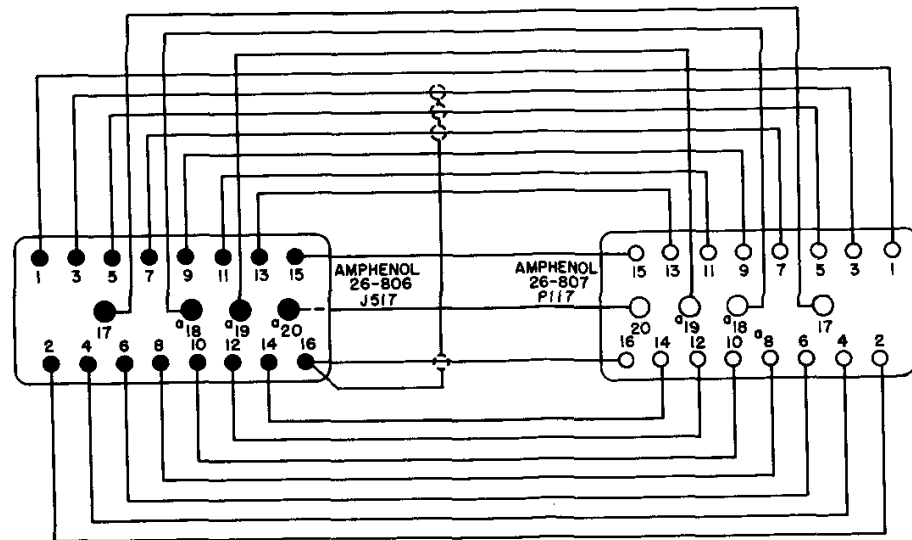

CABLE NO.8

Figure 70. Assembly instructions for extension cables No. 2 through 8.

REAR

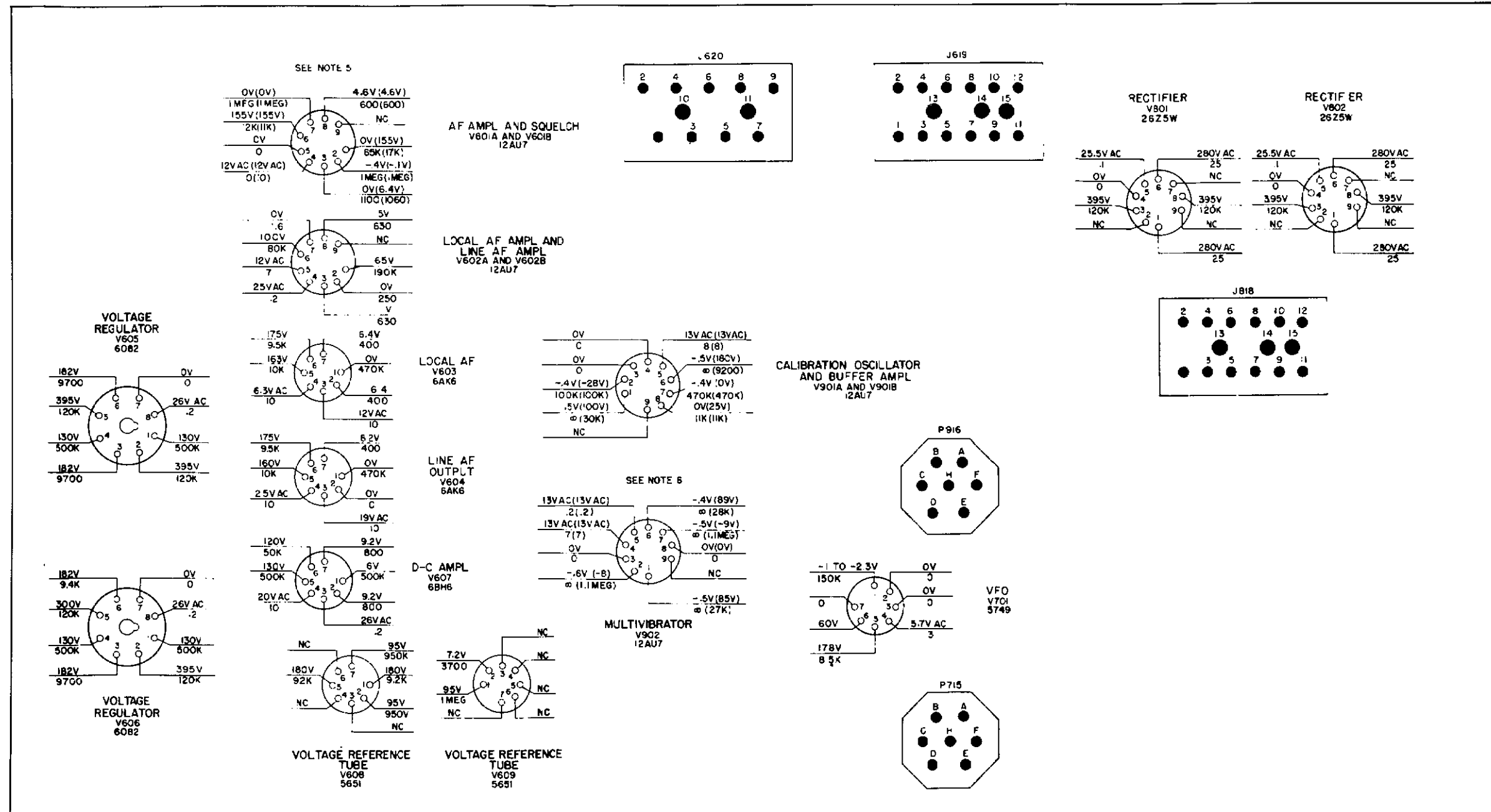

FRONT

NOTES:

- UNLESS OTHERWISE SHOWN, RESISTANCES ARE IN OHMS AND ARE MEASURED FROM SOCKET PIN TO GROUND. VOLTAGES ARE DC AND ARE MEASURED FROM SOCKET PIN TO GROUND WITH A V<sup>o</sup>VM (SUCH AS ELECTRONIC MULTIMETER TS-505/J. READINGS ARE THE SAME ON ALL BANDS.
- NC INDICATES NO CONNECTION.
- ∞ INDICATES INFINITY.
- UNLESS OTHERWISE NOTED, SET CONTROLS AS FOLLOWS:  
SET S801 TO 115 VOLTS AC, [FUNCTION] TO [AGC]  
[AUDIO RESPONSE] TO [MED], [RF GAIN] TO [10] [LOCAL GAIN] TO [10], AND [BANDWIDTH] TO [8KC]
- READING IN PARENTHESES ARE MADE WITH [SQUELCH] AT [ON].
- READING IN PARENTHESES ARE MADE WITH [FUNCTION] AT [CAL].

Figure 71. Bottom deck, voltage and resistance measurements.

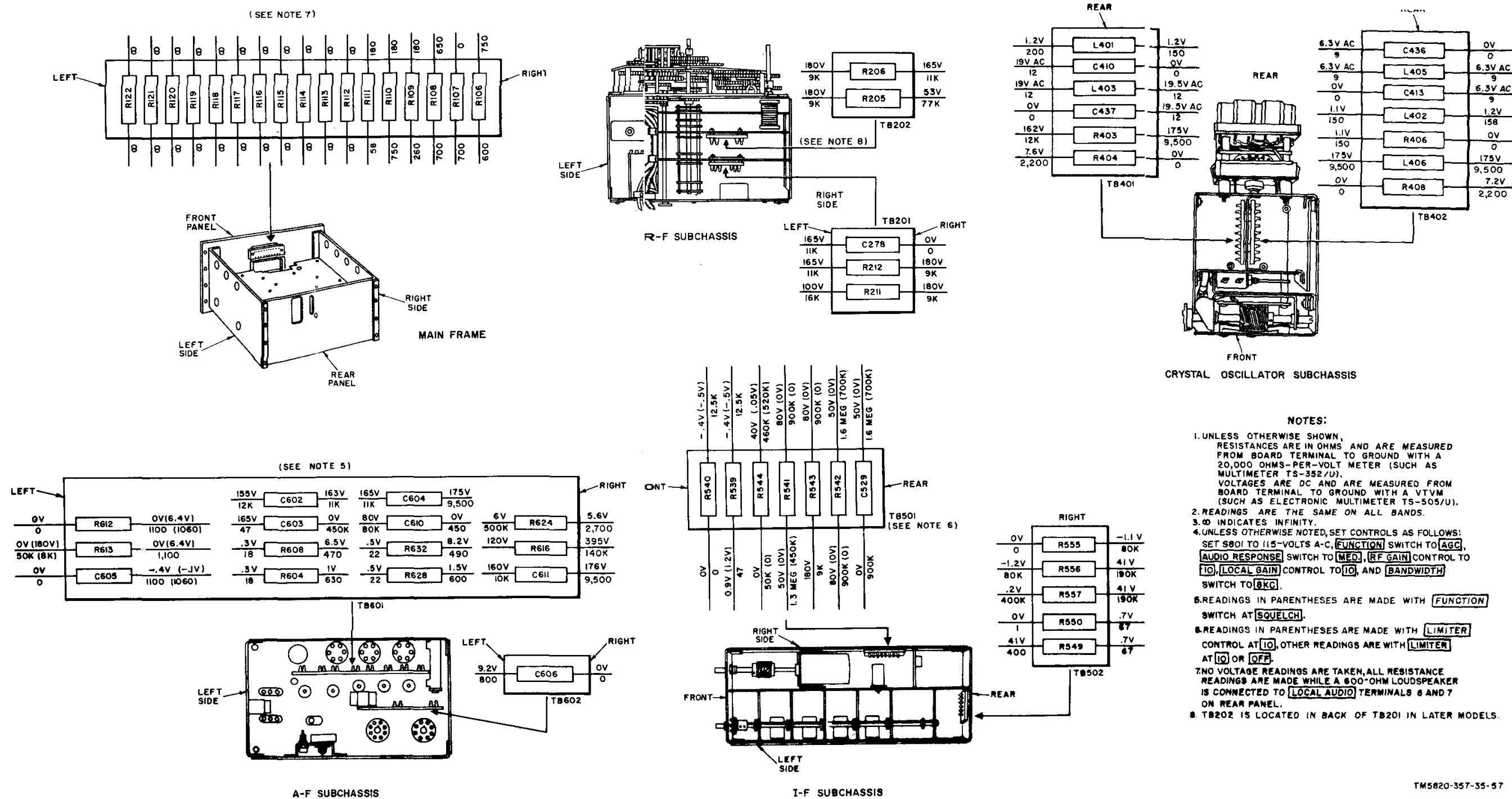
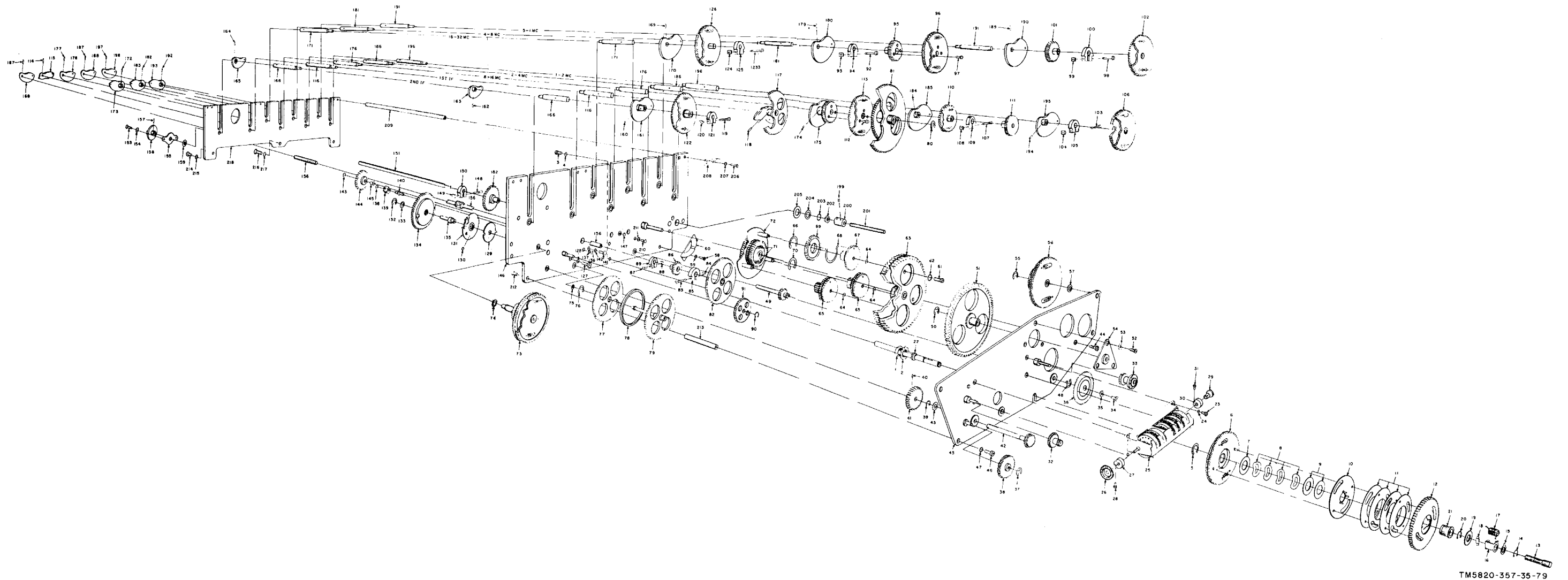

Figure 72. Terminal boards, voltage and resistance measurements.



TM5820-357-35-79

Figure 73. Mechanical tuning system, exploded view.



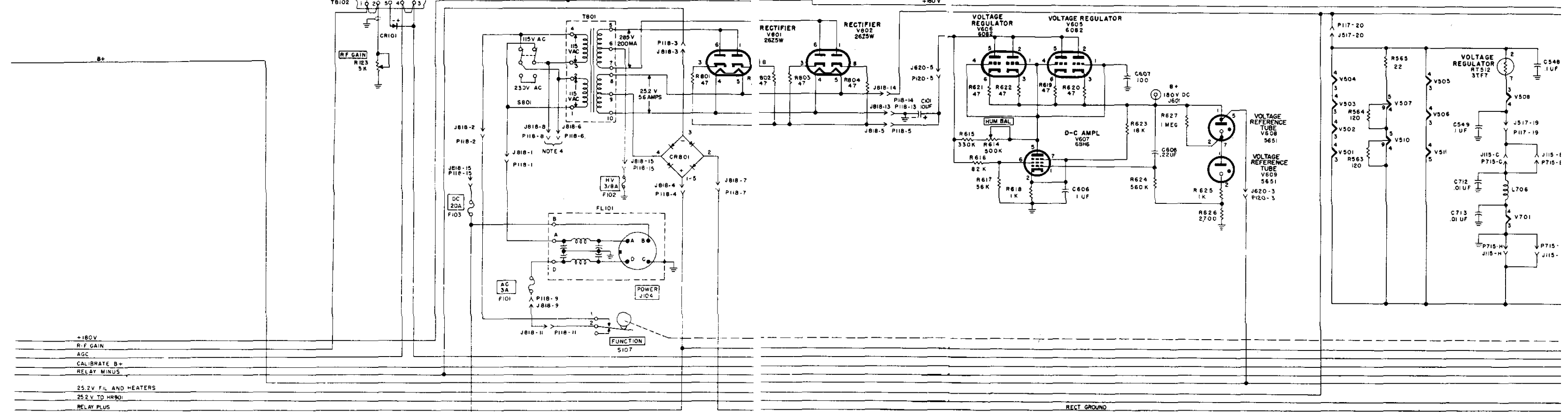
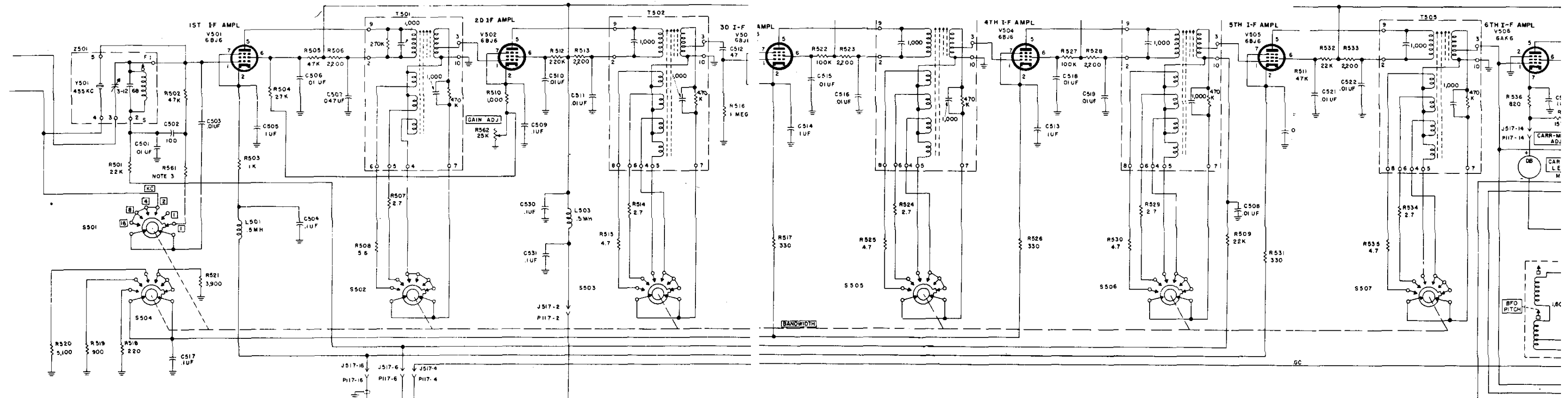

+180V  
 R-F GAIN  
 AGC  
 CALIBRATE B -  
 RELAY MINUS  
 25.2V FIL AND HEATERS  
 25.2V TO HR501  
 RELAY PLUS

RECT GROUND

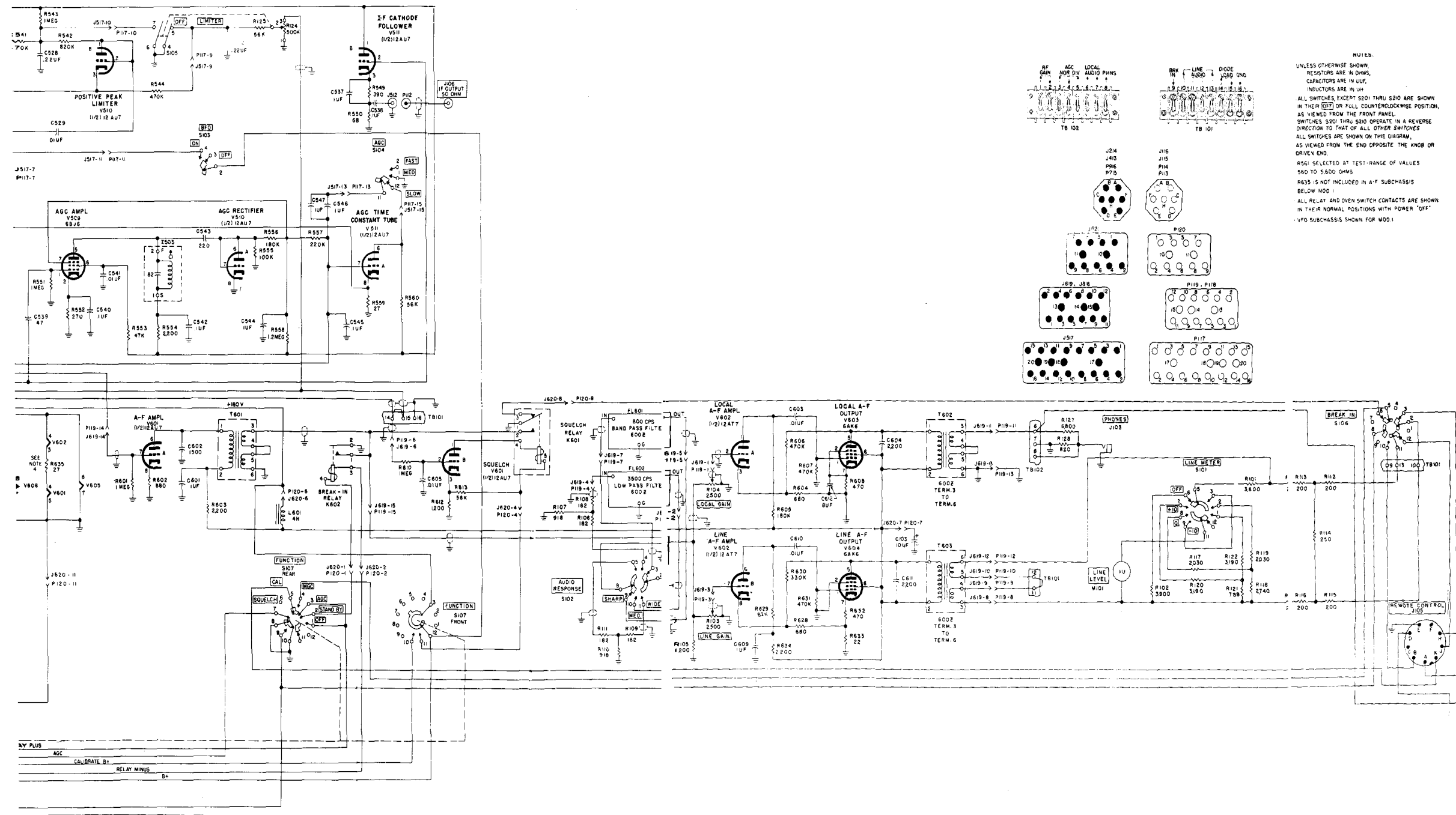

Figure 74 2. Radio Receiver R-390/URR, main schematic diagram (part 2 of 2).

# INDEX

	Paragraph	Page		Paragraph	Page
Adjustments:			Test, depot.....	107	133
Beat frequency oscillator calibration.....	68	74	Theory .....	21	20
Calibration-oscillator.....	70	74	Bench testing.....	47	41
Carrier level meter .....	69	74	Block diagram .....	3	-4
Gain adjust potentiometer .....	71	75	Break-in circuit, theory.....	37	35
Hum balance control .....	74	90	Buffer amplifier .....	30	30
Neutralizing capacitor .....	82	98	Calibration and antenna relay tests.....	87	101
Synchronization:			Calibration, bfo.....	68	74
Camshafts .....	73a	88	Calibration-oscillator:		
Crystal-oscillator band switch .....	73c	89	Adjustment.....	70	3
Six-position rf band switch .....	73b	89	Block diagram .....	74	4
Vfo tuning shaft .....	73d	89	Subchassis removal and replacement.....	64	71
Age circuit, theory.....	22	20	Test fourth echelon .....	87	101
Alignment:			Depot.....	108	133
First crystal oscillator .....	78	94	Theory.....	28	27
First variable If. amplifier .....	80	96	Camshafts, synchronizing.....	73	88
455-kc if. amplifiers .....	76	91	Carrier level meter:		
Rf stages.....	81	96	Adjustment .....	69	74
Second crystal oscillator.....	77	94	Cathode follower, theory.....	23	23
Second variable if. amplifier .....	79	95	Theory .....	22d	23
Special tools required .....	75	91	Charts:		
Test equipment required .....	75	91	Function switch S107.....	36	33
Amplifiers, theory:			Stage gain .....	52	57
Age V509.....	22	20	Troubleshooting.....	49	42
Audio frequency V601 .....	24	24	Voltage and resistance, fig. 55, 56, 57		
Buffer V901b.....	30	30	Checking:		
Fifth if. V505 .....	18	17	Oscillator crystals.....	51	57
First if. V501.....	80	96	Shorts.....	46	40
First rf V201 .....	5	7	Circuit:		
455-kc if.....	16	17	Antenna.....	3a	4
Fourth if. V504.....	17	17	Calibration-oscillator.....	28	27
Line at V602.....	26	26	Carrier level meter, theory.....	22d	23
Line output V604.....	26	26	Circuits:		
Local at V602.....	25	25	Bandwidth selection, theory.....	13	12
Local output V603.....	25	25	Coaxial cable assembly .....	47	41
Second if. V502.....	16	17	Control theory.....	37	35
Second rf V202.....	6	7	Coils:		
Sixth if. V502 .....	19	19	Resistance .....	54	58
Third if. V503.....	17	17	Rf tuning.....	66	71
Am. sensitivity tests:			Conversion scheme rf and if.....	55	65
Antenna balance ratio tests, depot.....	114	135	Crystal filter theory .....	13	12
Antenna circuits, theory.....	4	6	Crystal oscillators:		
Depot.....	98	130	First crystal oscillator, alignment.....	78	94
Fourth echelon.....	89	109	First crystal oscillator, theory.....	8	8
Antenna relay grounding test, depot.....	113	134	Second crystal oscillator, alignment.....	77	94
Assembly:			Second crystal oscillator V402, theory..	10	9
Coaxial cables .....	47-	41-	Crystal-oscillator subchassis		
	48	42	Removal.....	60a	69
Gear train			Replacement .....	60b	69
Audio:			Dc resistances of transformers and coils....	54	58
Distortion test:			Delayed age theory.....	22b	22
Depot.....	103	132	Detailed analysis, tuning system.....	40	37
Fourth echelon .....	92	121	Detector, theory.....	20	19
Output test, depot.....	102	131	Diagram		
Subchassis removal .....	65a	71	Schematic, Radio Receiver R390/URR, fig. 76		
Subchassis replacement .....	65b	71	Voltage and resistance		
Automatic gain control test, depot.....	104	132	Lower deck, fig. 72		
Band switch S501, synchronizing.....	73	88	Terminal boards, fig. 73		
Bandwidth selection circuits, theory.....	92	121	Top deck, fig. 39		
Beat frequency oscillator:			Wiring, interconnecting, fig. 75		
Calibration.....	68	74			

	Paragraph	Page
Dial calibration and resetability test, depot.	106	133
Differences in models.....	2	3
Disassembly, rf gear train.....	72	77
Distortion test, fourth echelon.....	92	121
Electrical synchronization.....	73	88
Equipment required, fourth echelon.....	83	98
Extension cables, coaxial.....	47	41
Fifth if. amplifier V505.....	18	17
Filament circuit:		
Checking for shorts.....	46	40
Theory.....	33	31
First crystal oscillator:		
Alignment.....	78	94
Theory.....	8	8
First if. amplifier:		
Alignment.....	80	96
Theory.....	15	16
First mixer V203, theory.....	7	7
First rf amplifier V201, alignment.....	81	96
First rf amplifier V201, theory.....	5	7
Forms and records.....	1	3
Fourth echelon testing:		
Antenna relay.....	87	101
Audio output.....	91	117
Beat frequency oscillator.....	88	105
Calibration-oscillator and antenna relay.....	87	101
Distortion.....	92	101
Equipment required.....	83	98
General.....	82	98
<i>I</i> <sub>f</sub> output.....	88	105
Inspection.....	86	100
Limiting.....	90	113
Line level meter.....	90	113
Operational.....	93	123
Performance standard summary.....	94	127
Physical tests.....	86	100
Sensitivity.....	89	109
Setup.....	47	41
Special test facilities.....	84	99
Squelch circuit, theory.....	90	113
Fourth if. amplifier V504, theory.....	17	17
Frequency conversion chart.....	55	65
Frequency range test, depot.....	105	132
Front panel:		
Removal.....	58 <i>a</i>	66
Replacement.....	58 <i>b</i>	67
Functional analysis, mechanical tuning.....	39	36
Function switch.....	36	33
Gain adjustment potentiometer		
Gear assembly:		
Removal.....	72 <i>a</i>	77
Replacement.....	72 <i>b</i>	80
Gear train legend.....	73	88
General precautions.....	72	77
Geneva system and overtravel coupler.....	39 <i>b</i>	36
Hum balance adjustment.....	74	90
If. amplifiers		
Alignment.....	76,	91
.....	79,	95
.....	80	96
Conversion scheme.....	55	65
Output tests:		
Depot.....	111	134
Fourth echelon.....	88	105

	Paragraph	Page
Subchassis:		
Removal.....	61 <i>a</i>	69
Replacement.....	61 <i>b</i>	69
Tests.....	50 <i>d</i>	50
Theory.....	14	16
Troubleshooting Inspection:		
Fourth echelon.....	86	100
Visual.....	45	40
Intermittent troubles.....	42 <i>b</i>	38
Internal differences in models.....	2	3
Isolating troubles within stage.....	53	58
Kilocycles control, theory.....	38 <i>a</i>	35
Legend, gear train.....	72	77
Limiter clipping level test, depot.....	112	134
Limiters theory.....	20	19
Limiting, fourth echelon testing.....	90	113
Line audio channel V602A, theory.....	26	26
Line level meter, fourth echelon testing.....	90	113
Line level meter test, depot.....	110	134
Local audio output V206B, theory.....	25	25
Localization, troubleshooting.....	49	42
Measurements		
Voltage.....	47	41
Resistance.....	47	41
Mechanical synchronization.....	73	88
Mechanical tuning system:		
Detailed analysis.....	40	37
Functional analysis.....	40	37
MEGACYCLE CHANGE control.....	39	36
Mixers:		
First mixer theory.....	7	7
Second mixer theory.....	9	8
Modification work orders.....	85	99
Multivibrator.....	29	27
Neutralizing capacitor, adjustment.....	82	98
Operational test:		
Depot.....	115	135
Fourth echelon.....	93	123
Organization, troubleshooting procedures.....	42	38
Oscillators:		
Calibration:		
Adjustment.....	70	74
Crystal oscillator subchassis removal.....	60	69
Crystals, checking.....	51	57
First crystal oscillator:		
Alignment.....	78	94
Theory.....	8	8
Second crystal oscillator:		
Alignment.....	77	94
Theory.....	7	7
Subchassis removal.....	64 <i>b</i>	71
Theory.....	28	27
Variable frequency oscillator.....	12	12
Oven heater circuits theory.....	34	33
Overall gain test, depot.....	101	131
Overall selectivity test,.....	100	131
Panel, front:		
Removal.....	58 <i>a</i>	66
Replacement.....	58 <i>b</i>	67
Parts replacement techniques.....	56	66
Performance standards summary.....	94	127
Physical tests and inspections, fourth echelon.....	86	100

	Paragraph	Page
Plate and screen voltage distribution.....	35	33
Plate circuits, checking for shorts.....	45	40
Power Supply PP-621/URR:		
Removal .....	62a	70
Replacement .....	62b	70
Theory .....	31	30
Principles of operation, mechanical tuning system:		
Detailed analysis .....	40	37
Functional analysis .....	41	38
Rectifier, age, V510.....		
Removal:		
Af subchassis .....	65a	71
Calibration-oscillator subchassis.....	64a	71
Crystal-oscillator subchassis .....	60a	69
Front panel .....	58a	66
Gear train assembly .....	72a	77
General .....	72	77
If. subchassis .....	61a	69
Power Supply PW621/URR .....	62a	70
Rf coils and transformers.....	66a	71
Rf subchassis .....	59a	67
Vfo subchassis .....	63a	70
Replacement:		
Af subchassis .....	65b	71
Calibration-oscillator subchassis .....	64b	71
Crystal-oscillator subchassis .....	60b	69
Front panel .....	58b	67
Gear train assembly .....	72b	80
If. subchassis .....	61b	69
Mechanical tuning-system parts legend .....	72c	84
Parts .....	56	66
Power Supply PP-621/URR.....	62b	70
Rf subchassis .....	66b	72
Vfo.....	63b	70
Resistance measurements:		
Coils.....	54	58
Transformers .....	54	58
Rf amplifiers:		
Alignment:.....	81	96
Conversion scheme.....	55	65
Theory .....	5-6	7-7
Rf band switch S501, synchronization.....	73	88
Rf gear train:		
Assembly .....	72b	80
Disassembly .....	72a	77
Scope of manual.....	1	3
Second crystal oscillator:		
Alignment .....	77	94
Crystal location .....	51	57
Theory .....	10	9
Second if. amplifier, theory.....	16	17
Second mixer, theory.....	9	8
Second rf. amplifier V202, theory.....	6	7
Second variable if. stage V502.....	16	17
Alignment .....	79	95
Theory .....	16	17
Sectionalization, troubleshooting.....	42b	
Selectivity test, depot .....	100	131
Sensitivity test, fourth echelon.....	89	109
Shorts check .....	46	40
Signal substitution, troubleshooting.....	50	44
Sixth if. amplifier theory.....	19	19
Special test facilities, fourth echelon.....	84	99
Squelch circuit, theory .....	27	27
Squelch tests, fourth echelon.....	90	113
Squelch threshold test, depot.....	109	133

	Paragraph	Page
Stage gain charts .....	52	57
Subchassis removal, general .....	59	67
Substitution, signal .....	50	44
Synchronization, mechanical and electrical .....	73	88
Test equipment required:		
Alignment .....	75	91
Troubleshooting .....	50	44
Testing, bench .....	47	41
Tests, depot:		
Am. sensitivity .....	98	130
Antenna balance ratio .....	114	135
Antenna relay grounding .....	113	134
Audio harmonic distortion .....	103	132
Automatic gain control .....	104	132
Bfo .....	107	133
Calibration-oscillator .....	108	133
Cw sensitivity .....	99	131
Dial calibration and resetability .....	106	133
Frequency range .....	105	132
If. output .....	111	134
Limiter clipping level .....	112	134
Line level meter .....	110	134
Maximum audio output .....	102	131
Operational checks .....	115	135
Overall gain .....	101	131
Overall selectivity .....	100	131
Squelch threshold .....	109	133
Tests, fourth echelon:		
Antenna relay.....	87	101
Audio output .....	91	117
Beat frequency oscillator .....	88	105
Calibration-oscillator .....	87	101
Distortion .....	92	121
Equipment required .....	83	98
Operational .....	44	39
Physical .....	86	100
Sensitivity .....	89	109
Setup .....	47	41
Special test facilities .....	84	99
Squelch operation.....	90	113
Summary of performance standards.....	94	127
Theory:		
Agc amplifier V509.....	22	20
Antenna circuit .....	4	6
Audio amplifiers .....	24	24
Bandwidth selection circuits .....	13	12
Beat frequency Oscillator V508 .....	21	20
Calibration-oscillator .....	28	27
Carrier level meter circuits .....	22d	23
Cathode follower .....	23	23
Control circuits .....	37	35
Delayed agc circuits .....	22b	22
Detector V507 .....	20	19
Fifth if. amplifier V505 .....	18	17
Filament circuit .....	33	31
First crystal oscillator V401 .....	8	8
First if. amplifier V501 .....	15	16
First mixer V203 .....	7	7
First rf amplifier V201 .....	5	7
455-kc if. amplifier.....	14	16
Fourth if. amplifier V504 .....	17	17
Function switch S107 .....	32	31
Kilocycles control .....	40b	37
Megacycles control.....	40a	37
Multivibrator V .....	29	27
Noise limiter V507, V510.....	20	19

	Paragraph	Page		Paragraph	Page
Oven heater circuits .....	34	33	Localization .....	49	42
Plate and screen voltage distribution.....	35	33	Power supply subchassis P-621/URR....	62	70
Rf and if. ago rectifier circuit theory.....	22	20	Precautions.....	41	38
Second crystal oscillator V402.....	10	9	Rf subchassis.....	50 <sup>e</sup>	46
Second mixer V204.....	9	8	Sectionalization .....	42 <sup>b</sup>	38
Second rf amplifier V202.....	6	7	Signal substitution .....	50	44
Second variable if. amplifier V502.....	16	17	Troubleshooting chart.....	49	42
Sectionalization, troubleshooting.....	42 <sup>b</sup>	38	Troubleshooting, isolation within stage.....	53	58
Sixth if. amplifier V506 .....	19	19	Tuning system, mechanical:		
Squelch circuit V601 .....	27	27	Detailed analysis .....	40	37
Third and fourth if. amplifiers V503			Functional analysis .....	41	38
and V504 .....	17	17	Variable frequency oscillator:		
Time constant system, ago.....	22	20	Subchassis:		
Transformers:			Removal .....	63 <sup>a</sup>	70
Removal.....	66 <sup>a</sup>	71	Replacement.....	63 <sup>b</sup>	70
Replacement .....	66 <sup>b</sup>	72	Theory.....	12	12
Transformers, dc resistance.....	54	58	Tuning shaft, adjustment.....	73 <sup>d</sup>	89
Troubleshooting:			Variable rf and if. conversion scheme.....	55	65
Audio subchassis .....	50 <sup>c</sup>	44	Visual inspection .....	45	40
Calibration-oscillator subchassis.....	50	44	Voltage and resistance charts, fig. 39, 72,		
Chart .....	50	44	73.		
Crystal-oscillator subchassis .....	50	44	Voltage distribution.....	35	33
Equipment required.....	50	44	Voltage measurements.....	42 <sup>b</sup>	38
General .....	42-	38	Voltage regulator.....	32	31
.....	50 <sup>b</sup>	44	Zero adjust control.....	40 <sup>c</sup>	37
If. subchassis .....	50 <sup>d</sup>	45			

By Order of Secretary of the Army:

G. H. DECKER,  
General, United States Army,  
Chief of Staff.

Official:

J. C. LAMBERT,  
Major General, United States Army,  
The Adjutant General.

Distribution:

Active Army:

DASA (6)	POE (1)
USASA (2)	OSA (1)
CNGB (1)	USAEPG (2)
Tech Stf, DA (1) except	AFIP (1)
CSigO (18)	AMS (1)
Tech Stf Bd (1)	Army Pictorial Cen (2)
USCONARC (5)	EMC (1)
USAARTYBD (1)	Yuma Test Sta (2)
USAARMBD (2)	USACA (3)
USAIB (1)	USASSA (20)
USARADB (2)	USASSAMRO (1)
USAAVNBD (1)	USASEA (1)
USAABELCTBD (1)	USA Carib Sig Agcy (1)
USAATBD (1)	USA Sig Msl Spt Agey (13)
ARADCOM (2)	Sig Fld Maint Shops (3)
ARADCOM Rgn (2)	USA Corps (3)
OS Maj Comd (3)	Def Log Svc Cen (1)
OS Base Comd (2)	JBUSMC (2)
LOGCOMD (2)	Pueblo Ord Dep (2)
MDW (1)	USMA (2)
Armies (2)	USASCS (99)
Corps (2)	QMRECOMD (2)
Instl (2)	Units org under fol TOE:
Ft Monmouth (63)	(2 each UNOINDC)
USATC AD (2)	11-7
USATC Armor (2)	11-16
USATC Engr (2)	11-32
USATC Inf (2)	11-57
USATC FA (2)	11-85
USAOMC (3)	11-98
Svc College (2)	11-117
Br Svc Sch (2)	11-155
GENDEP (2) except	11-157
Atlanta GENDEP (None)	11-500 AA-AK (4)
Sig Sec, GENDEP (5)	11-557
Sig Dep (12)	11-587
WRAMC (1)	11-592
USA Trans Tml Comd (1)	11-697
Army Tml (1)	

NG: State AG (3) Units same as active Army except allowance is one copy to each unit.

USAR: None.

For explanation of abbreviations used, see AR 320-50.

RECOMMENDED CHANGES TO EQUIPMENT TECHNICAL PUBLICATIONS



THEN...JOT DOWN THE  
DOPE ABOUT IT ON THIS FORM.  
CAREFULLY TEAR IT OUT, FOLD IT  
AND DROP IT IN THE MAIL.

SOMETHING WRONG WITH PUBLICATION

FROM: (PRINT YOUR UNIT'S COMPLETE ADDRESS)

DATE SENT

PUBLICATION NUMBER

PUBLICATION DATE

PUBLICATION TITLE

BE EXACT PIN-POINT WHERE IT IS

PAGE NO.	PARA-GRAPH	FIGURE NO.	TABLE NO.
----------	------------	------------	-----------

IN THIS SPACE, TELL WHAT IS WRONG  
AND WHAT SHOULD BE DONE ABOUT IT.

TEAR ALONG PERFORATED LINE

PRINTED NAME, GRADE OR TITLE AND TELEPHONE NUMBER

SIGN HERE

