

FREQUENCY-SHIFT KEYERS

The keyboard contacts of the teletypewriter actuate a direct-current circuit that operates the printer magnets, and a pair of terminals is provided that connect to a key. In the "resting" condition the contacts are closed (mark). In operation the contacts open for "space." These contacts may be used to operate a keyer circuit of the radio transmitter, provided it is not "loaded" to such an extent that it affects the operation of the printer.

Perhaps the simplest satisfactory circuit for frequency-shift keying a v.f.o. is the one shown in Fig. 10-6. This uses a diode to switch a capacitor in and out of the circuit. Although shown for 455 kc., the v.f.o. can be made to operate on any reasonable frequency by substituting suitable inductance and capacitance values.

The triode oscillator uses the series-tuned Colpitts circuit, with the actual frequency adjustment done by changing the inductance. The closed contacts of the printer complete the voltage-dividing circuit (1200- and 120K resistors), and the 1N67 is heavily back-biased. The effect is to open the circuit between C_1 and C_2 , and C_2 is substantially out of the circuit.

When the contacts open, the anode of the 1N67 has +150 volts applied, and the diode is heavily forward-biased. The effect is to switch C_1 and C_2 (in series) into the circuit. The net capacitance that is inserted determined by the setting of C_1 , the shift adjustment.

A buffer amplifier follows the v.f.o., with a

capacitance voltage divider reducing the available voltage to the amplifier but furnishing further buffer action. At 455 kc., it should be possible to short circuit the output terminals without shifting the oscillator frequency more than a few cycles. As in any oscillator, solid construction and the use of good components is recommended.

Frequency Adjustment

The frequency shift, whatever the type of circuit, should be made as nearly exact as available equipment will permit, since the shift must match the frequency difference between the filters in the receiving converter if the signals are to be usable at the receiving end. An accurately calibrated audio oscillator is useful for this purpose. To check, the mark frequency should be tuned in on the station receiver, with the b.f.o. on, and the receiver set to exact zero beat. (See Chapter 21 on measurements for identification of exact zero beat). The space frequency should then be adjusted to exactly the desired shift. This may be done by adjusting for an auditory zero beat between the beat tone from the receiver and the tone from the audio oscillator. If an oscilloscope is available, the frequency adjustment may be accomplished by feeding the receiver tone to the vertical plates, and the audio-oscillator tone to the horizontal plates, and then adjusting the space frequency for the elliptical pattern that indicates the two frequencies are the same.

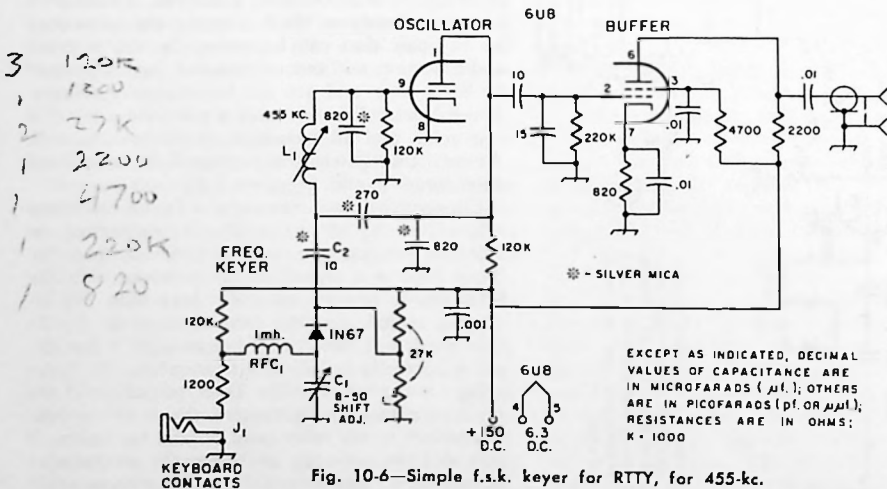

Fig. 10-6—Simple f.s.k. keyer for RTTY, for 455-kc. operation.

- C_1 —8-50-pf. trimmer (Centralab 822-AN)
- C_2 —10-pf. silver mica

- J_1 —Shorting type headphone jack
- L_1 —330-410- μ h. adjustable coil (Miller 42A334CBI)

RCF₁—1-mh. subminiature choke (Millen J300-1000)

A comprehensive series of articles on RTTY, far beyond the possible scope of this Handbook, was carried monthly in QST during 1965.

Written by Irvin Hoff, K8DKC, and starting in the January issue, they are recommended reading for any RTTY enthusiast.