

Teletype Model 33 and 32  
Training Manual B-52

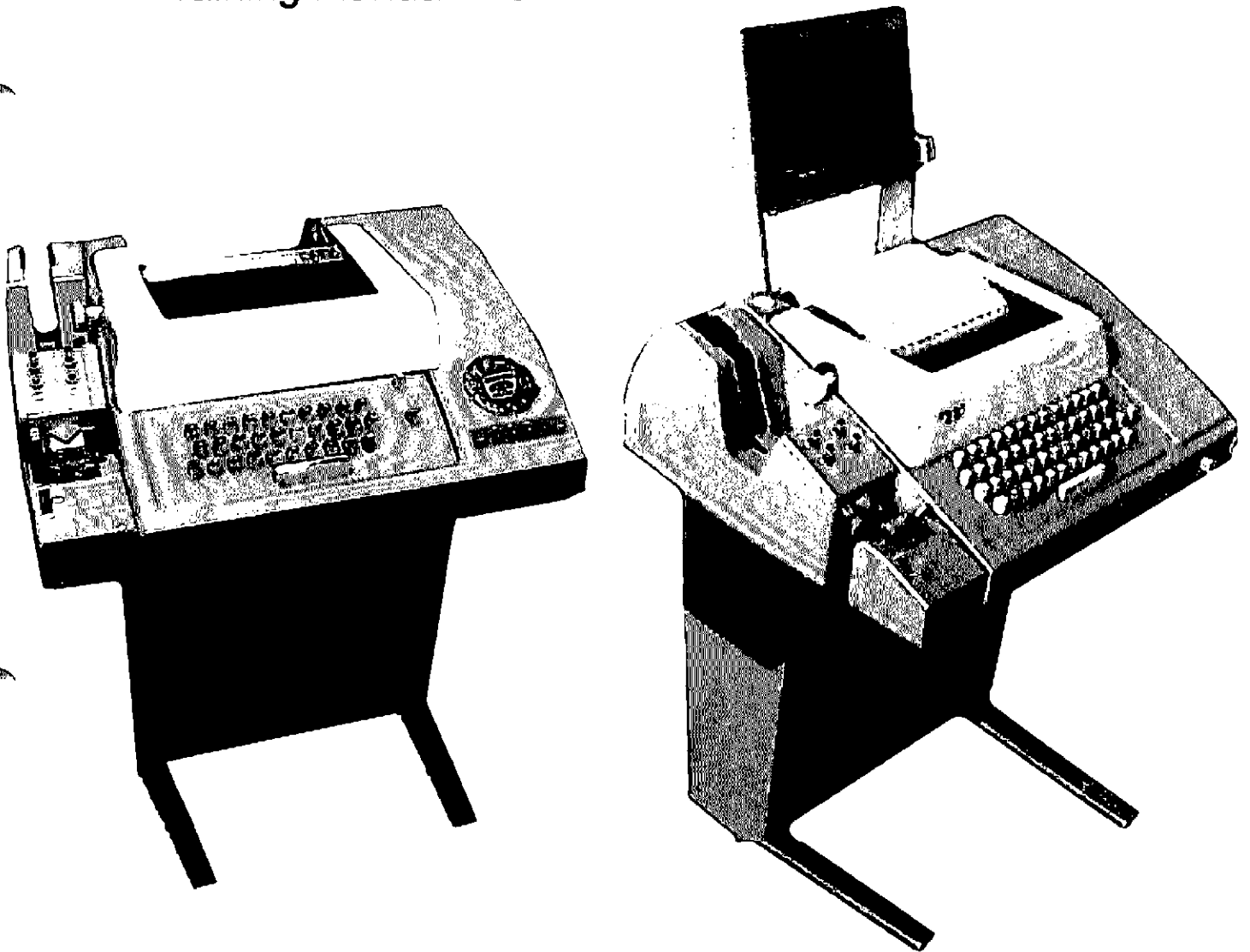

Presented by the General Telephone Co. of Ohio  
and Teletype Corporation, a subsidiary of Western Electric

General Telephone Company of Ohio  
Plant Training Course B-52  
Model 33 Teletype Equipment

1. INTRODUCTION

The objective of this guide is to outline the essential principles of the Teletype signaling codes.

This guide will discuss the basic five-level code and the more advanced eight-level code, more commonly referred to as the American Standard Code for Information Interchange, (ASCII).

## 2. TELETYPE HISTORY

The invention of the teletype cannot be attached to any one particular person, but evolved through the years from 1849 to the present date through improvements and modifications to the modern teletypewriters.

The Bell System entered the teletype field in 1915 when a private line circuit was installed for the Associated Press. More systems followed and about 1925, the first switching system was installed for the Detroit Edison Company. The next major step was a state-wide system for the Pennsylvania State Police with four switching centers. This led to the establishment of national switching center plan of the TWX (Teletypewriter Exchange Service). Growth of teletype is a result of customer need for adequate communications. There are in excess of 150,000 TWX stations in service, and it is still growing.

The program of mechanized TWX has been in the planning stage for some time and was completed with a flash cut-over on September 2, 1962. This being the latest step now permits direct connection of machines nationwide without the use of an operator to switch the calls manually. The machines were cut with 60 W.P.M. operation and are now operating at 100 W.P.M.

2.1 In ordinary telegraph transmission, as devised by Samuel Morse, intelligence is relayed from one point to another by the making and breaking of the signal line. The operator at the transmitting end of the line opens and closes a key activating a sounder at the receiving station. These sounds are translated by the receiving station operator into the characters and symbols making up the message.

The drawbacks to this system are of course quite obvious. A network of telegraph stations can pass traffic only as fast as the slowest operator can send or receive. There is the constant possibility of a miss-sent or erroneously copied character with no way of verifying the transmission. Also, every station requires constant attendance.

To overcome these weaknesses a French signal officer, named Jean Baudot, envisioned a method of mechanically transmitting a signal that would activate a printing mechanism. The new method of printing telegraphy required modification of the basic Morse code. The primary change was the control over the time interval of each transmitted pulse. Specified time intervals of pulse lengths were to replace the arbitrary dot-dash system of each operator.

In order to encompass the 26 letters of the alphabet and a number of purely mechanical functions required to operate a printing mechanism, Mr. Baudot determined that the basic conditions, (current-on-line, no current-on-line), would have to be expanded. He accomplished this by taking the two basic conditions and raising them to the fifth power, ( $2^5 = 2 \times 2 \times 2 \times 2 \times 2$ ), for a total of 32 possible combinations. Therefore, each character is a combination of five pulses, with each pulse having two possible conditions.

The two conditions referred to above shall be called by their more common names, current-on-line - MARKING, no current-on-line = SPACING, throughout the remainder of this guide.

Subsequent to the development of this basic code, a printer was developed with the addition of an uppercase, referred to as FIGURES, thereby expanding the capabilities of the code to twice as many characters, or 64 possible characters.

In the lower case, or letters, we have the 26 letters of the alphabet plus 6 or more, so called, "functions." These functions are mechanical operations of the printer as opposed to the actual printing of a character. They include:

Letters (LTRS) = Either shifting the type box to the letters segment or alpha position.

Figures (FIGS) = Shift the typebox to print numeric

Space = Moving the printing mechanism to leave a blank between words.

Carriage Return (C.R.) = Returning the printing mechanism to the left margin.

Line Feed (L.F.) = Feeding the paper out of the printer.

Blank = All pulses spacing - used for various operations.

## 2.2 Types of Service

Private Line Service - Private Line Teletypewriter Service provides a direct and continuous connection between two or more teletypewriters at specific points. This service is provided under a monthly contract. It does not connect with a central office. It may be provided on one of three options: one-way, half-duplex (two-way alternate), and full-duplex which is two-way simultaneous messages. It is available at three speeds: 60, 75, and 100 words per minute). The average word consists of five characters and one space. In the binary counting system, this equals 46, 57, or 74 bits per second. Some special applications using high speed data sets may be accessed to the same line or facility. Other special features include automatic tape transmission, selective arrangement for accessing a particular station, direct feeding into typesetting machines.

MTWX - Teletypewriter service is furnished on an exchange basis and the messages are completed via exchange or toll switching facilities. Mechanized teletypewriter service was inaugurated on a national basis September 2, 1962. The teletypewriter is equipped with a subset that has a dial and a receiver and is connected to a central office equipped for direct distance dialing and automatic number identification. All teletype stations are assigned an exchange number of seven digits plus the NPA code of three digits. Most stations will be provided on half-duplex arrangements although full-duplex is available with the subset provided. To reach an office with DDD and ANI, the teletypewriter will be connected via a loop circuit. All calls will be completed by dialing a ten-digit number.

Other services such as collect calls and conference calls will be handled by operators at special boards for teletype stations. At this time, all machines will be set for 60 words per minute operation. In the future, this will be changed to 100 words per minute.

### 3. ANALYZING A CHARACTER

As we saw on the preceding page, the basis for our present day Teletype Code is the mechanical control of the combinations of MARK and SPACE conditions associated with the individual characters. The length of time duration of the individual pulses used to make a character is determined by the motor speed of the unit, which through a gear train, operates the various cams and levers that ultimately open and close the signal line. We may say then, that as the mechanical operating speed of the unit increases, the time interval of the total character decreases. A little later on we will show this graphically.

At the present time there are three basic transmitter shaft speeds in popular usage. They are 368 rpm, 460 rpm, and 600 rpm of shaft speed. A conversion of these speeds into the more widely used term "words-per-minute" may be accomplished by dividing each figure by 6. (This assumes that the average word contains five characters and a space between it and the next word.) Thus, 368 rpm becomes 60 wpm, 460 rpm is about 75 wpm, and 600 is 100 wpm. For maintenance or other technical purposes it is far more accurate to deal only with the actual shaft speed. If, for every revolution of the transmitting shaft a complete character is transmitted, we may state that a complete operation has been performed. Therefore, our rpm's become operations-per-minute.

The first step in determining the total time of a single character is determining the operations-per-second.

$$(A) \frac{600 \text{ rpm}}{60 \text{ sec.}} = \text{operations-per-second} = 10 \text{ ops}$$

We now can say we transmit 10 characters-per-second, since each operation is a character.

The next step is to break these 10 characters down to find the time of a single character.

$$(B) \frac{1 \text{ sec.}}{10 \text{ ops}} = \text{one character} = .100 \text{ seconds}$$

We now see that at 600 opm each character is 1.00 seconds, or 100 milliseconds (MS) long. This same method may be used for any operating speed to determine the character length.

Before we can start breacking the individual character into its separate pulses, and determining their length, we have to consider one other facet of our individual character. In order that both the transmitting and receiving units are operating together (synchronization) additional pulses are required. They are called the START and STOP pulses. Since these pulses are attached to every character they are not considered information pulses. In the majority of applications the START and five information pulses are of equal length, with the STOP pulse being of a longer duration. This added length, (usually 42%) is a safety feature to insure that the receiving unit has time to completely detect the last information pulse before the transmitter begins the next character.

Example: 5-Level Code

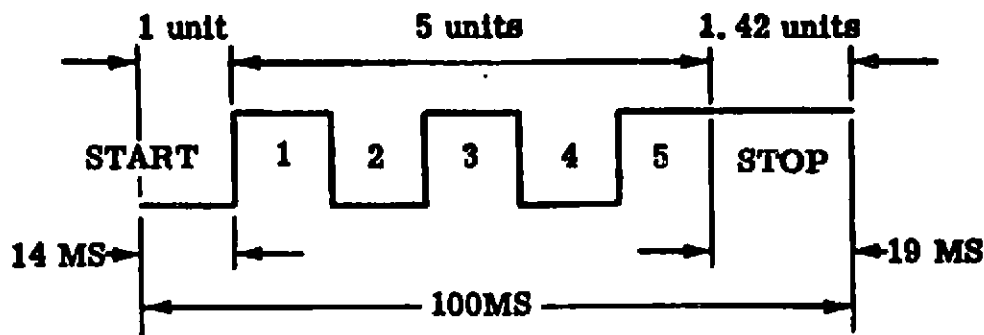

Start	=	1	unit
Information Pulses	=	5	units
Stop	=	$\frac{1.42}{7.42}$	unit units

The 7.42 unit character is known as the Standard Unit Code for five-level transmission. One exception to this standard is a straight 7 unit code. An example of this is Western Union, which uses a stop pulse the same length as the start and information pulses. This unit code plus a variance in shaft speed allows for 65 wpm operation. We will discuss this a little later in this guide.

Now to return to find the duration of each of the five individual information pulses and the start pulse:

$$(A) \frac{100 \text{ ms}}{7.42 \text{ units}} (\text{time for one character}) = 13.47 \text{ or } 14 \text{ ms} = 1 \text{ unit}$$

To find the length of the 42% longer stop pulse:

$$\begin{array}{r}
 \text{(B) } 13.47 \quad (\text{one unit}) \\
 \times 1.42 \quad (\text{one} + 42\%) \\
 \hline
 19.13 \quad \text{or } 19 \text{ ms} = \text{stop pulse}
 \end{array}$$

The above information applies to five-level only. Before trying to find the pulse length for the eight-level equipment we should note three things:

1. The total character length (in milliseconds), for any given shaft speed will be the same for both five and eight-level codes.
2. If the total character length (in milliseconds) is equal for both the 5 and 8 level codes: then it follows that the 8 level code employing 3 information code levels more than the 5 level must necessarily have each of its code pulse correspondingly shorter timewise.
3. Two units are used as the safety feature in the eight-level stop pulse.

Example: 8-level Code

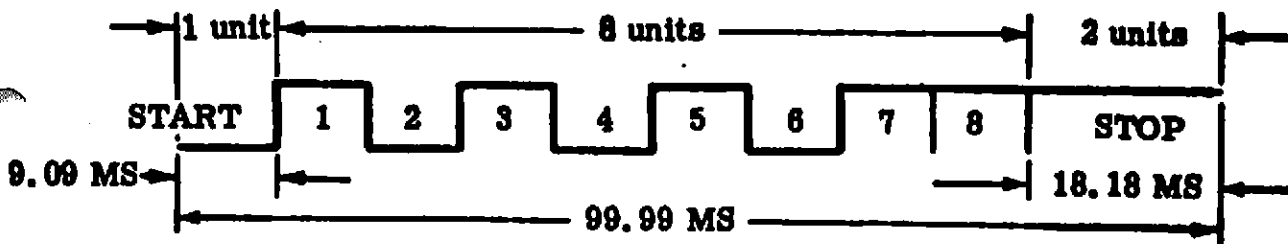

Start	=	1	unit
Information Pulses	=	8	units
Stop Pulses	=	$\frac{2}{11}$	units
		11	units

We now have an 11 Unit Code for eight-level transmission.

To determine the length of each pulse in the eight-level code, we use the same formula as in the five-level:

$$\text{(A) } \frac{100 \text{ ms}}{11 \text{ units}} \quad (\text{time for one character}) = 9.09 \text{ ms} = 1 \text{ unit}$$

To find the length of the double stop pulse:

$$\begin{array}{r}
 \text{(B) } 9.09 \quad (\text{one unit}) \\
 \times 2 \quad (\text{double stop pulse}) \\
 \hline
 18.18 \text{ ms} = \text{stop pulse}
 \end{array}$$

As you have probably noticed in the signal diagrams, the start pulse has been represented as a no current-on-line (SPACING) condition, and that the stop pulse has been drawn as a current-on-line (MARKING) condition. This holds true for both five and eight-level because the normal, or "REST" condition of the signal line is with current-on-line. If the normal condition is MARKING the beginning of the next character must alter that condition. Obviously then, the start pulse must be no current or SPACING. The end of the character must return the signal line to its normal condition so the stop pulse or pulses must be MARKING.

#### 4. TELETYPEWRITER SIGNAL RECEPTION

It should be remembered that no matter what form of transmission is used between teletypewriters, that the printing magnets of the machines always operate from one of two current conditions: (1) 62.5 milliamperes of current for marking and no current for spacing; or (2) 20 milliamperes of current for marking and no current for spacing. This is known as neutral operation.

The pulse from the line pass through the magnet winding and cause its armature to move back and forth under control of the marking and spacing elements. The START element (spacing) causes the armature to be released and operate a trip-off device. This permits a selection cam to start rotating at a definite speed. Depending on whether the encoding elements which follow are marking or spacing, the code bars will be positioned either to the left or right. This operation sets up the rest of the mechanism to print the selected character. The STOP element (marking) causes the trip-off device to return to its original position.

The selecting mechanism is arranged to operate only momentarily during the reception of the central portion of the marking and spacing encoding elements. From this it can be seen that because the rotation of the selecting cam is at a constant speed, the operation of the rotated selector can be related time-wise to the beginning of the START pulse. Square pulses can be shifted behind or ahead time-wise 40% of an encoding element length and still produce perfect copy. This is because the momentary operation of the selector is still within the reception interval of the element. (The figure is not 50% because of internal characteristics of the machine.)

##### 4.1 POLAR OPERATION

Until now only NEUTRAL operation has been discussed. We have seen in NEUTRAL, operation a SPACE has been the NO current-on-line condition, and a MARK is the current-on-line condition. In POLAR operation, there is current on the signal line at all times. It is the polarity of the current that determines whether a MARK or a SPACE is being transmitted. The MARKING signal will have a positive voltage, and the SPACING signal will use a negative voltage of the same amplitude.

Obviously, the receiving machine could not be directly connected to a POLAR signal line because current, no matter what polarity, would energize the magnets in the selector mechanism. That is to say, a magnet cannot differentiate between a positive or negative voltage, and we would initiate the same actions and responses for both a MARKING and SPACING impulse. Therefore, a relay or selector magnet driver mechanism is used between the receiver and the signal line.

Either of these devices converts the POLAR signal line transmission to a NEUTRAL signal for use by the selector assembly in the receiving equipment.

The following signal diagram graphically portrays the difference between NEUTRAL and POLAR operation for any current, code level, or speed.

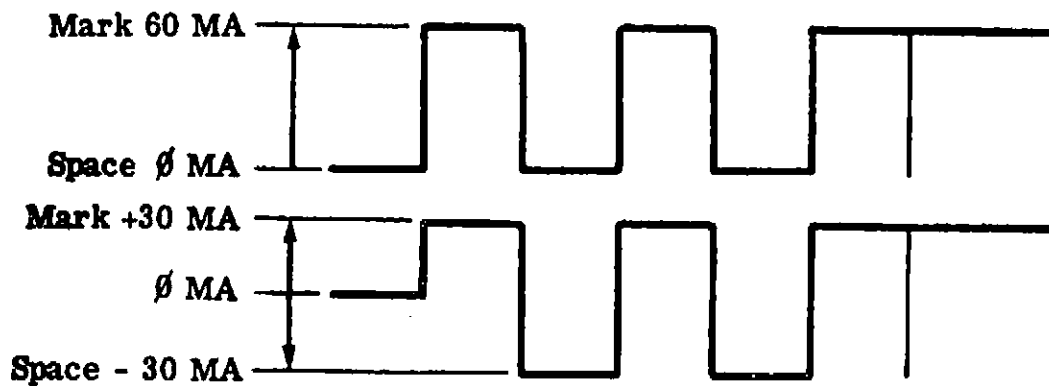

## 5. BAUD RATE

The word baud is derived from the name Baudot (Ref. p.1). The baud rate, sometimes called the bit rate, is simply an expression which combines both shaft speed (operations-per-second) and the particular unit code being used into one usable term or figure. It indicates the maximum usable number of pulses-per-second that a given piece of equipment can handle.

The main use for the baud rate is compatibility between equipment. If we have a transmitter and receiver with equal baud rates we know that traffic can be passed between them. An unequal baud rate tells us that without modification, or additional equipment we cannot transmit between the equipment in question.

To find the baud rate multiply the operations-per-second by the unit code being used.

Example:                    5-level    60 wpm

$$\frac{368 \text{ opm}}{60 \text{ sec.}} = 6.13 \text{ ops} \times 7.42 \text{ unit code} = 45.5 \text{ baud}$$

Let's do the same computation using the Western Union shaft speed and 7.00 unit code, (Ref. p.3).

$$\frac{390 \text{ opm}}{60 \text{ sec.}} = 6.5 \text{ ops} \times 7.00 \text{ unit code} = 45.5 \text{ baud}$$

We can see from the above examples that although the shaft speeds and unit codes differ, these units would be compatible because of equal baud rates.

One more example of baud rate is the eight-level code.

Example:                    8-level    100 wpm

$$\frac{600 \text{ opm}}{60 \text{ sec.}} = 10.0 \text{ ops} \times 11.0 \text{ unit code} = 110 \text{ baud}$$

The increase of either the operations-per-second, or the unit code increases the baud rate. Remember, baud rate is simply a term of compatibility. Before leaving the baud rate we should clarify the difference between baud rate and bit rate. The speed of a unit in bits-per-second is not equal to the speed in bauds unless all pulses or bits of a character are of equal duration. The following chart will illustrate the relationship between shaft speed (opm), bits and bauds.

<u>WPM</u>	<u>UNIT CODE</u>	<u>OPM</u>	<u>BAUD</u>	<u>BITS</u>	<u>UNIT INTR.</u>	<u>CHAR. INTR.</u>
61.3	7.42	368	45.5	42.9	22 MS	163 MS
65	7.00	390	45.5	45.5	22 MS	154 MS
75	7.42	460	56.9	52.5	17.6 MS	130 MS
100	7.42	600	74.2	70.0	13.5 MS	100 MS

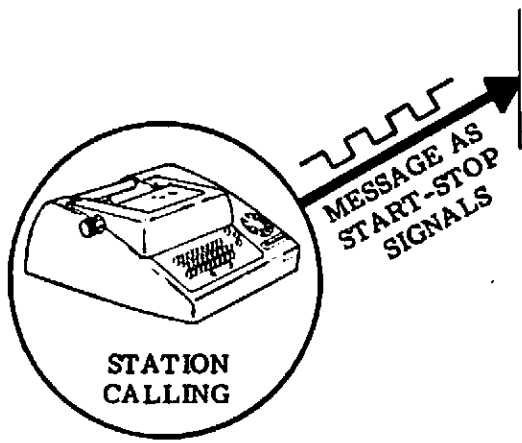

to

ss-

### TELETYPEWRITER CODE

1.03 Teletypewriters transmit and receive messages by means of a binary permutation code (Figures 1 and 2). The characters making up the messages (letters, numerals, symbols, functions, etc) are represented by pre-arranged combinations of binary intelligence elements (also referred to as levels, or bits), each of which may be in one of two states—on or off. Depending on whether a 5- or 8-level code is employed, each combination consists of five, six, seven, or eight intelligence elements. The total number of permutations available in a given code is equal to 2 to the  $n^{\text{th}}$  power, where "n" is the number of intelligence elements. For example, in a 6-level code, there are 2 to the 6<sup>th</sup> power, or 64, permutations.

1.04 In the various stages of a communication system using teletypewriter equipment, the above code may occur in a number of different forms, including parallel or sequential electrical pulses, mechanical positions of parts, code holes in paper tape, and tone frequencies. For transmission purposes, it is placed in an electrical form referred to as a start-stop signaling code, or simply a teletypewriter code (Figures 1 and 2). The intelligence elements are applied sequentially to a signal line as current or no-current time intervals. Intervals during which current flows in the signal line are referred to as "marking" elements, and intervals during which no current flows as "spacing" elements. To insure synchronization between the transmitting and receiving equipment, a start element, which is always "spacing," is added at the beginning of each combination of intelligence elements, and a stop element, which is always "marking," is added at the end.

1.05 In different signaling codes, the length of the stop element may vary. For example, in the teletypewriter code illustrated in Figure 1, the length of the stop element is 1.5 times the other elements. Thus, the transmission of a character requires 7.5 units of time. It is therefore said to have a 7.5-unit transmission pattern.

#### A. 32 Typing Units

1.06 The teletypewriter code accommodated by the 32 typing unit is illustrated in Figure 1. Since it has five intelligence elements and its stop element is 1.5 units of time, it is a 5-level code with a 7.5-unit transmission pattern. It has 2 to the 5<sup>th</sup> power, or 32 available permutations.

1.07 To accommodate more than 32 characters, a letters-figures shift is designed into the typing unit. This is similar to the lower and upper case of a typewriter and permits each code combination, excluding the two used to shift the equipment, to represent two characters.

1.08 A character arrangement is shown on the chart in Figure 1. The black circles represent marking elements; the blank squares represent spacing elements. When the "letters" code combination (12345) is transmitted, it conditions all typing units connected to the circuit to print, at the receipt of all following code combinations, the characters in the letters (lower case) line on the chart. Similarly, when the "figures" code combination (12-45) is transmitted, it conditions the typing units to print the characters or perform the functions in the figures (upper case) line on the chart.

#### B. 33 Typing Units

1.09 The American Standard Code for Information Interchange (ASCII) accommodated by the 33 typing unit is illustrated in Figure 2. Since it has eight intelligence elements and its stop element is 2 units of time, it is an 8-level code with an 11-unit transmission pattern. However, at the present it utilizes only the first seven intelligence elements, the eighth being used to provide an error detection feature called "even parity." When "even parity" is not provided, the eighth intelligence element is always transmitted as a marking element. Thus, it has 2 to the 7<sup>th</sup> power, or 128, available permutations. Of these combinations, 64



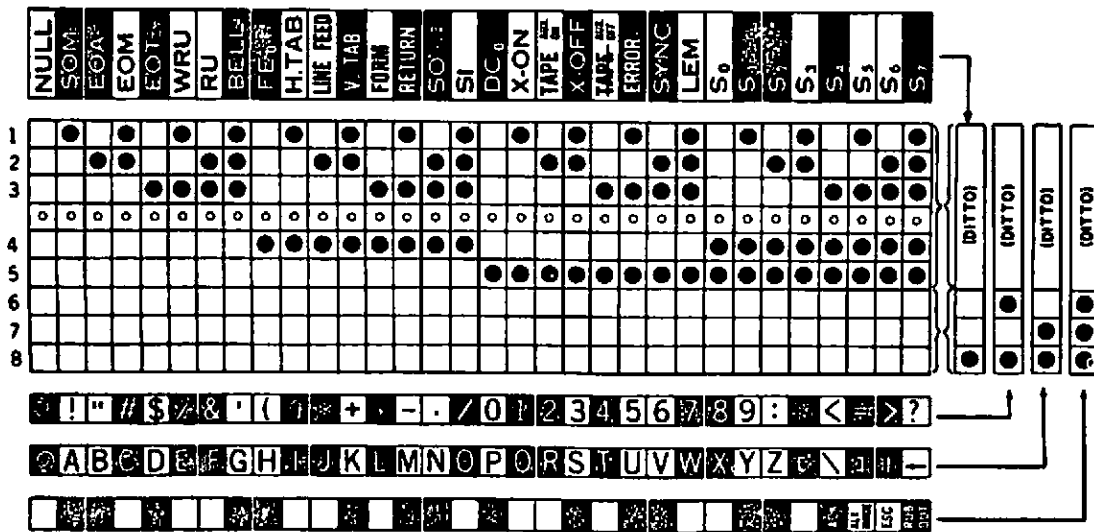

CHARACTER ARRANGEMENT (ASCII CODE)

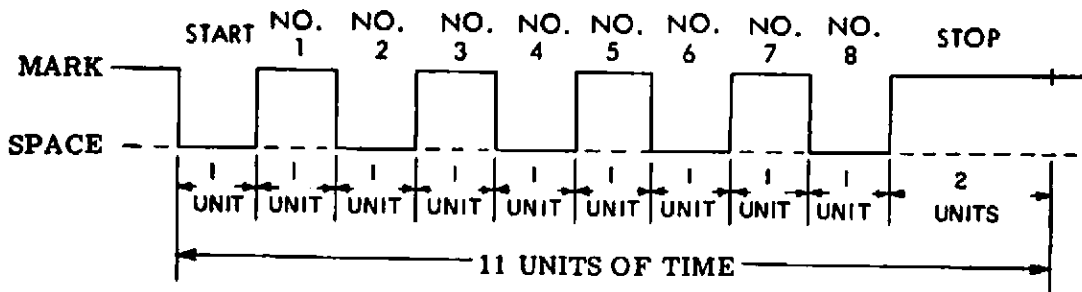

CURRENT WAVE FORM FOR LETTER "U" (WITH "EVEN PARITY")

Figure 2 - Teletypewriter Code (8-Level)

are assigned to printing characters. The rest are devoted to control (nonprinting) characters, or are unassigned.

Note: "Even parity" is an error detection feature which provides for adding a pulse whenever the number of marking pulses in a code combination is odd.

1.10 The character arrangement for the ASCII code is shown on the chart in Figure 2. The black circles represent marking elements,

the blank squares spacing elements. The main block gives the arrangements of elements 1 through 5. The four smaller blocks at the right give the arrangements of elements 6 and 7 for the four rows of characters as indicated by the arrows. When "even parity" is provided, characters and functions which have white backgrounds in the character arrangement chart have the eighth intelligence element spacing—dark backgrounds have the eighth intelligence element marking. For keyboard transmission, two SHIFT keys and a CTRL key are used as covered in the appropriate keyboard section.

## 6. SIGNAL DISTORTION:

For purposes of illustration, Teletype pulses are shown as perfect rectangular waveshapes with sharp transitions and precise timing. This optimum condition is seldom, if ever, found in actual practice.

The modification of the original, rectangular waveshape is called DISTORTION. The Total Distortion to any signal is broken down into three categories for purposes of classification, but it is also important to note that any signal may contain all three components of distortion. The three components of distortion are:

Bias Distortion  
Characteristic Distortion  
Fortuitous Distortion

Bias and characteristic distortion are combined in the term Systematic Distortion because both occur in response to natural law and, consequently, either is roughly predictable. With the third element, Fortuitous Distortion, uncontrollable occurrences (hits on the line, Loose ground connections, etc.), are accounted for. With the introduction of the selector magnet driver, distortion has been greatly reduced. Inasmuch as signal distortion does still exist, the following may prove helpful.

### 6.1 BIAS DISTORTION:

Bias Distortion effects all pulses uniformly and its effect upon a MARK is opposite to its effect upon a SPACE. Bias may alter either the beginning or the end of an impulse, but inasmuch as the selector always begins with the MARK-to-SPACE transition of the Start pulse, the total effect of bias is to advance or retard the leading edge of any impulse.

Before illustrating Bias, it will be necessary to indicate the effect, upon a signal pulse, by the resistive, inductive and capacitive elements in the signal line.

1. Perfect MARK impulse.
2. Line INDUCTANCE opposes sudden transition of current. Inductance from Line Relays and/or selector magnet coils.
3. Line CAPACITANCE shunts the signal line preventing rapid current build-up and, thus, further sloping the edges of the wave.

Fig. 1

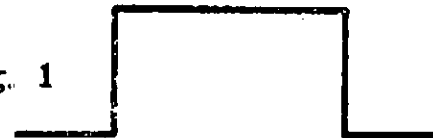

Fig. 2

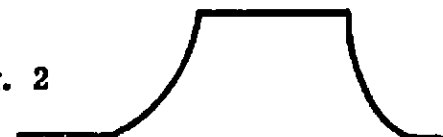
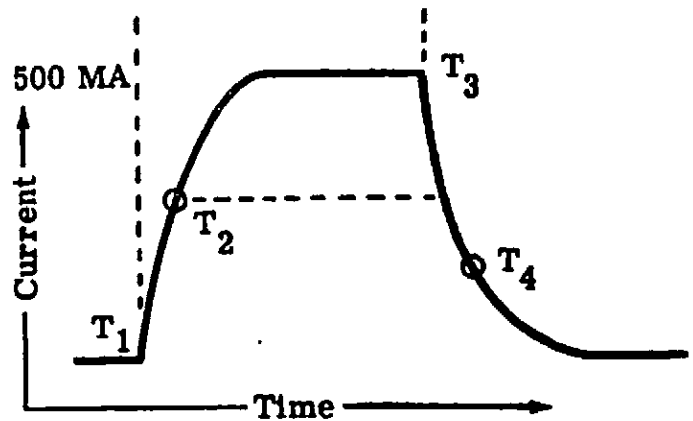

Fig. 3



The impulse in Figure 3 is more likely to be found at the receiving printer than the one impressed at the transmitter, (Figure 1). The impulse seen in Figure 3, as applied to the selector magnets of the printer, will be used to illustrate Bias Distortion. It will be noted that this waveshape builds up to its 500 ma level gradually.

Instead of picking up at the leading edge of the pulse (T1), the selector magnet will energize at a somewhat later time -- say, for example, at T2 -- or, whenever the current has reached a level where it generates sufficient magnetic attraction. This point, T2, would be the beginning of the MARK impulse as far as the selector was concerned.



When, at the end of the transmitted pulse, the current again starts towards 0 ma, the selector armature should, theoretically, fall away at T3. The trailing edge of the impulse, however, also slopes, consequently, a definite time will have elapsed before the armature will drop away (T4). Notice that T2 and T4 are not identical current values. The de-energization point will be of lower value due to residual magnetism in the coils.

The time between when the armature should attract (T1) and when it does attract (T2) is known as SPACE-to-MARK TRANSITION DELAY. (Abbr. S-MTD). The time between when the armature should drop away (T3) and when it does drop away (T4) is known as MARK-to-SPACE TRANSITION DELAY. (Abbr. M-STD).

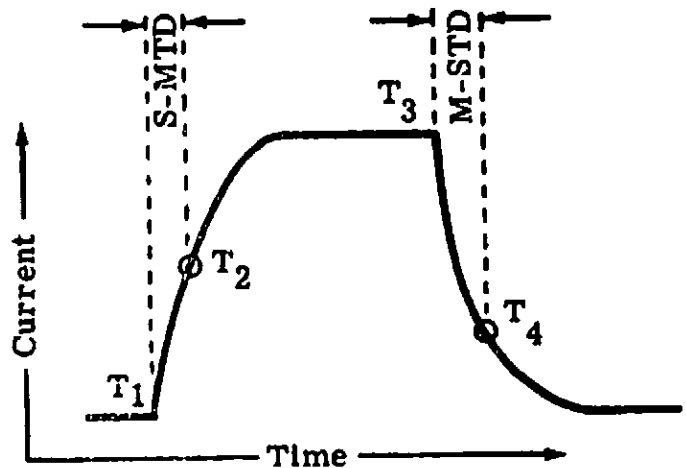

If the S-MTD is equal to the M-STD, the pulse as seen by the selector would be undistorted.

If the S-MTD is greater than the M-STD, the pulse has been shortened and the condition is known as SPACING BIAS.

If the M-STD is greater than the S-MTD, the pulse has been lengthened and the condition is known as MARKING BIAS.

The Bell System uses the following formula to determine the actual Bias condition in milliseconds (ms). The sign of the result indicates whether the Bias is MARKING (+) or SPACING (-).

$$M-STD - S-MTD = ms. \text{ Bias}$$

This example of Bias Distortion illustrates that although the M-STD may not equal the S-MTD, the two will be consistent for any given circuit and/or adjustment. It will be noted, also, that the effect of Bias will:

- a) Be the opposite to a SPACE from its effect upon a MARK.
- b) Be consistent for any character combination.

#### CHARACTERISTIC DISTORTION

Characteristic Distortion, as the name implies, is determined by the signal line characteristics. That is, the resistance, capacitance and inductance of the signal line. This type of distortion will effect different characters in different ways but it will always be consistent for the same character. In neutral operation, Characteristic Distortion will effect Bias.

Characteristic Distortion has varying effects upon different characters because the circuit's reactance will have less chance to become stabilized when characters with many current transitions are applied (U for example) than when characters with few transitions are applied (SPACE for example).

The contrast between Characteristic Distortion and Bias may be summarized as follows:

1. The effect of Characteristic Distortion depends upon the length of the impulse transmitted. The effect of Bias is independent of the impulses.
2. For a given length of impulse, the effect of Characteristic Distortion is independent of whether it is a marking or spacing impulse. The effect of Bias is always opposite on a mark to what it is on a space.

3. Characteristic Distortion is related to the amount and arrangement of the capacitance, inductance and resistance of a circuit. Except in neutral operation, these factors do not effect Bias.
4. Bias is caused by unequal marking and spacing line current, biased relays, etc., conditions which do not effect Characteristic Distortion.
5. Characteristic Distortion, because it is due to the capacitance, inductance and resistance of a circuit, which except for the resistance, are unchanging in value, varies only a small amount from day to day. Bias, because it is caused by uneven potentials, relays losing adjustment, etc., may vary from hour to hour.

### 6.3 FORTUITOUS DISTORTION

This form of distortion covers such unpredictable occurrences as sudden battery fluctuations or loose ground connections. This distortion may effect any portion of any character and little or no compensation can be made for it.

It may shift a signal transition either way in a fortuitous or "chance" manner from which it derives its name. For this reason, it affects both ends of the margin range about equally, which is one of its most prominent characteristics.

### 7. RANGE

All Teletype receivers (i.e., printers, reperforators, etc.) are equipped with a range scale. In every case, the function of the range scale is to orient the mechanical selector to the electrical signal to obtain maximum selecting margins, (receiving margin).

The selecting interval of the impulse (i.e., when the actual selection is made) is only 20% of the pulse width. Consequently, a perfect selector should be able to tolerate 40% distortion of both leading and trailing portions of an impulse.

In a perfect impulse the necessary 20% selecting interval would be in the center with a range reading of 10 to 110:

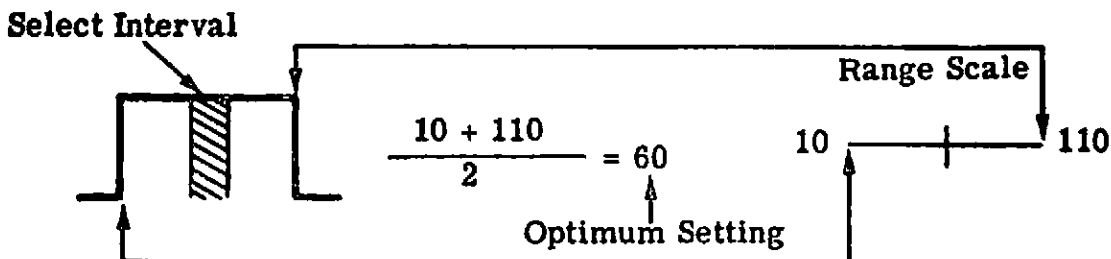

In any situation, there is a standard procedure for determining the proper setting for the range scale:

- a) Determine the high and low points on the range scale by moving the range scale indicator toward the upper limit until errors are observed in copy, then toward the lower limit until errors are again observed, (one error per two lines of copy).
- b) Add the high point to the low point and divide by two, for optimum setting.

(See examples in range illustrations)

If 20% MARKING END DISTORTION were introduced, the optimum setting would shift. To maintain the selecting interval in the middle of the pulse, will require the reorientation of the range scale indicator.

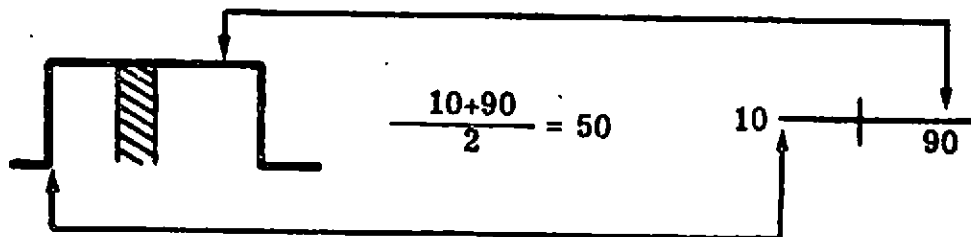

If 20% SPACING END DISTORTION were introduced the range would shift in an opposite direction, also requiring reorientation of the range scale indicator.

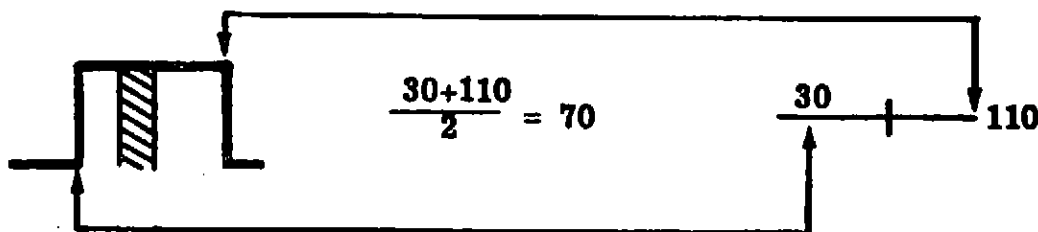

For additional information on a general description of the  
Model 33 TTY, see the following General System Practices:

- A - 574-100-102 - Description
- B - 574-100-201 - Installation
- C - 574-100-800 - List of Modifications
- D - 574-126-100 - Cover - adj. lub, disassembly
- E - 574-126-700 - Adjustment
- F - 574-126-800 - Cover and table - parts list

GLOSSARY OF TERMS

Bail - A straight, or curved bar or blade, held or pivoted at the ends or middle. The bail in contrast to the bell cranks or lever does not change the direction of movement, but imparts motion to other parts which may come in contact with it at various points along its length.

The bail on the left shows above moves to the left and pushes the bar to the left.

Baud - The number of bits transmitted per second. Arrived at by dividing the speed of the transmitting shaft by 60. Then multiplying the quotient by the stated unit code. Example:

$$\frac{600 \text{ CPM}}{60 \text{ sec.}} = 10 \text{ OPS} \times 11 = 110 \text{ Baud.}$$

Note: 11 is the unit code in this example but this figure can vary.

Baudot Code - A five-level teletypewriter code consisting of a start impulse and five information impulses all of equal length, and a stop impulse whose length is 1.42 times that of the start impulse. Also known as the 7.42 unit code.

Bell Crank - An "L" shaped lever rotating on a pivot fixed at the apex of the angle formed by the two arms and used to transmit and modify force and motion. The effect of the bell crank, illustrated below, causes a right angle change in the direction of movement. A movement upwards at the left of the bell crank is converted into a rightward movement at the upper end.

Bias, applied - A force (electrical, mechanical, or magnetic) applied to a relay or other device to cause it to hold or operate in a given direction.

Bias Distortion - A component of systematic distortion, which is such that interchanging the functions of the two current values used will change the sign of the systematic distortion but not its magnitude.

Bit - One impulse, or the time interval normally occupied by one impulse.

✓ Cam - A projecting or indented part of a wheel which imparts movement to a follower riding against the circumference of the cam.

Characteristic Distortion - A fixed distortion which results in either shortened or lengthened impulses. It generally does not change in degree from day to day.

Clutch - A device consisting of a driving and driven member which, when engaged, mechanically couples two working parts of a machine

Cycle - One complete course of recurring operations or events.

✓ Detent - A stop or holding device, as a pin, lever, etc., pressed against another party, such as a ratchet, cam or bail, to prevent their movement.

Duplex - Simultaneous transmission between two stations in both directions.

Eight-Level - Any teletypewriter code which utilizes eight impulses, in addition to a stop and start impulses, for describing a character.

Electromagnet - A core or magnetic material, such as soft iron, with a coil of wire surrounding it. In teletypewriter operation, the selector magnet.

End Distortion - A form of distortion which displaces the MARK-to-SPACE transition.

Five-Level - Any teletypewriter code which utilizes five impulses, in addition to the stop and start impulses, for describing a character.

Fortuitous Distortion - An intermittent distortion which results in either shortened or lengthened impulses. It may be caused by battery fluctuation, hits on the line, etc.

Gear - A set of cog wheels serving to transmit motion or change its rate or direction.

Helical or Spiral Gear - Gears with teeth running at an angle across the gear.

Hit on the Line - A momentary open circuit on a teletypewriter loop.

Keyboard perforator - A mechanism, consisting of a keyboard and a perforator, by which tape is perforated in accordance with a code corresponding to the depressed character key of the keyboard.

Lever - A rigid bar, turning freely on a fixed point or fulcrum and used for transmitting and modifying force and motion.

As in the above diagram with the fulcrum or pivot placed at some point in the middle of the lever, the ends of the lever move in opposite directions. When the right side moves down, the left side is moved up. This feature of the lever is widely used in Teletype apparatus. If the fulcrum is placed at the extreme end of the bar, the direction of movement is the same throughout the length of the lever.

Mark - An impulse which causes the signal loop to be closed. A current-on-line condition.

Marking End Distortion - End distortion which lengthens the marking impulse by delaying the MARK-to-SPACE transition.

Mark-Hold - The normal no-traffic line condition whereby a steady mark is transmitted.

Marking Bias - Bias distortion which lengthens the marking impulse by advancing the SPACE-to-MARK transition.

Marking Contact - The contact of a telegraph or teletypewriter receiving relay which is closed when the relay is operated by marking current.

Marking Current - That magnitude and polarity of current in the line when the receiving mechanism is operated to the marking position.

Milliampere - A rate of current flow. One one-thousandth of an ampere. Expressed as .001 ampere or as 1 milliampere.

Neutral Circuit - A teletypewriter circuit in which current flows in only one direction. The circuit is closed during the marking condition and open during the spacing condition.

### GENERAL DESCRIPTION

The Model 33 teletypewriter is an electromechanical communication apparatus that utilizes a four-row keyboard and an eight level code. It provides terminal facilities for exchanging information via appropriate communication facilities such as telegraph lines, telephone networks, radio channels, and carrier equipment. It is manufactured in 3 forms:

1. As a Send Receive Page Printer (KSR)
2. As a Receive-Only Page Printer (RO)
3. As an Automatic Send-Receive Set (ASR)

The KSR and ASR equipments employ a standard 4-row keyboard that can be operated by any typist without additional training.

Transmission and reception are effected by a start-stop signaling code (also referred to as the 8 Level American Standard Code for Information Interchange (ACII), which is carried by the transmission facilities.

Equipment may be used with DTWX or private line service. When used with DTWX, a Call Control Unit located to the right of the keyboard and printer is used to provide facilities for initiating, accepting, controlling, and completing calls through a data set connected with conventional telephone central offices.

When used on a private line service, two methods may be used:

1. With a Call Control Unit (cable connectors must have jumpered plugs and connectors)
2. Without a Call Control Unit, an Electrical Service Unit is used to connect directly to the signal line.

#### SEND-RECEIVE PAGE PRINTER SET

The KSR set provides facilities for originating messages for transmission by the manual operation of a keyboard and for receiving and printing messages, whether originated locally or remotely, on a page-width copy paper.

Consists of a Keyboard, Printer Assembly, Motor, Call Control Assembly, Sub-Base and Cover.

#### RECEIVE-ONLY PAGE PRINTER SET

The RO set provides facilities for receiving messages and printing them on page-width copy paper.

Consists of the same components as the KSR except the Keyboard is blank and has no facilities for transmission.

**AUTOMATIC SEND-RECEIVE SET**

The ASR set provides facilities for originating messages for transmission by either the manual operation of a keyboard or the reading of perforated paper tape. It provides facilities for recording messages, whether originated locally or remotely, by perforating them in tape and/or printing them on page-width copy paper. The ASR sets may be used in the following ways:

1. To transmit messages from the keyboard while making a printed page copy with or without perforating tape.
2. To receive messages from line and print them on page copy with or without perforating tape.
3. To locally perforate messages in tape from keyboard for later transmission while making a printed page copy.
4. To transmit messages from tape while making a page copy with or without perforating tape.

The basic ASR sets include the same components as the KSR with the addition of a tape reader and a tape punch, which mount on the left side of the keyboard and printer.

**CALL CONTROL UNIT**

Contains six pushbuttons - illuminated

Answer - Station goes off hook, into connect condition.  
 Clear - Stations disconnect, go on hook (idle)  
 Originate - Used to initiate a call  
 Test - Connects output of data set back to input  
 Local - Automatic answering facilities are disabled  
 Buzzer Release - Stops buzzer, sounds on low paper condition.

Also contains two printed circuit cards, a Selector Magnet Driver and Speaker Amplifier.

Contains a Ringer which is adjustable and a Speaker, which monitors the progress of the dialed call. A transformer supplying 48, 14, and 19V A. C. and a diode rectifier for the selector magnet driver.

**CALL CONTROL UNIT**  
(continued)**Contains:**

A restrain amber lamp.

A combination break release push button switch with a white lamp.

An out of service white lamp.

An out of service turn switch with a normal position and a spring return restore position.

The call control unit, when used with the 101C Data Set, is connected with conventional telephone central offices having the required routing and message accounting equipment. These are generally the same offices and equipment serving telephone customers in the area. Direct current signals are used for both originating and terminating traffic, providing the same conditions as for conventional local telephone set operation. The dial on the set, for initiation of call connections, may be either a d. c. pulsing or multi-frequency tone device.

The elapsed time indicator is mounted at the rear of the call control unit. It provides a means of logging hours for maintenance purposes, by logging the total number of motor operating hours. The lapsed time indicator is not resettable.

It is easily installed and has two electrical leads; one goes to the motor control relay, the other to the power transformer.

*Hindsight: the ability to see how a mistake looks from the rear*

EIGHT LEVEL DATA INTERCHANGE CODE -  
FOUR-ROW KEYBOARD

CONTENTS	PAGE
1. GENERAL .....	1
2. CODE .....	1
LEVELS 1 THROUGH 7.....	1
EIGHTH LEVEL .....	3
3. PRINTING CONTROL.....	3
GENERAL .....	3
PRINT SUPPRESSION.....	3
REVERSE SLANT (~) SYMBOL....	3
4. SHIFT FUNCTIONS .....	5
GENERAL .....	5
SHIFT KEY .....	5
CONTROL KEY.....	5

1. GENERAL

1.01 This section is reissued for the purpose of rearranging the material into a standard format and to add new Figure 3.

1.02 Teletypewriter equipment transmits and receives messages by means of a binary permutation code. The characters which make up the messages - letters, numbers, symbols, functions, etc. - are represented by prearranged combinations of binary intelligence elements (also referred to as levels, bits, units, or pulses), each of which may be in one of two states (on or off, etc.). The total number of permutations - or combinations - available in a given code is equal to two to the n power ( $2^n$ ), where n is the number of intelligence elements used to represent a character.

1.03 In the various stages of a communication

system using teletypewriter equipment, a code may be expressed in a number of different forms, including parallel or sequential electrical pulses, mechanical positions of parts, code holes in paper tape, and tone frequencies. For transmission purposes, the code is converted to an electrical form, and is referred to as a start-stop signaling code or simply as a teletypewriter code. The intelligence elements are applied sequentially to a signal line as current or no-current time intervals. Intervals during which current flows in the signal line are referred to as marking elements, and during which no current flows as spacing elements. To insure synchronization between the transmitting and receiving equipment, a start element (always spacing) is added at the beginning of each combination of intelligence elements, and a stop element (always marking) is added at the end (Figure 1).

2. CODE

2.01 The data interchange code is an eight-level code, with an eleven-unit transmission pattern (Figure 1). Although it has eight available levels for character formation, only the first seven intelligence elements are utilized, the eighth element being always transmitted as marking. Therefore, the code provides two to the seventh power ( $2^7$ ), or 128, available permutations (or combinations) for character formation. 64 of these combinations are assigned to printing characters (graphics). Of the remainder, some are assigned to control (non-printing) characters while others are un-

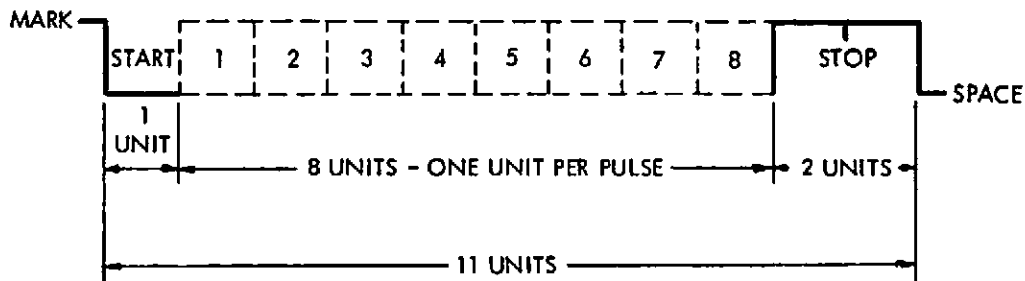
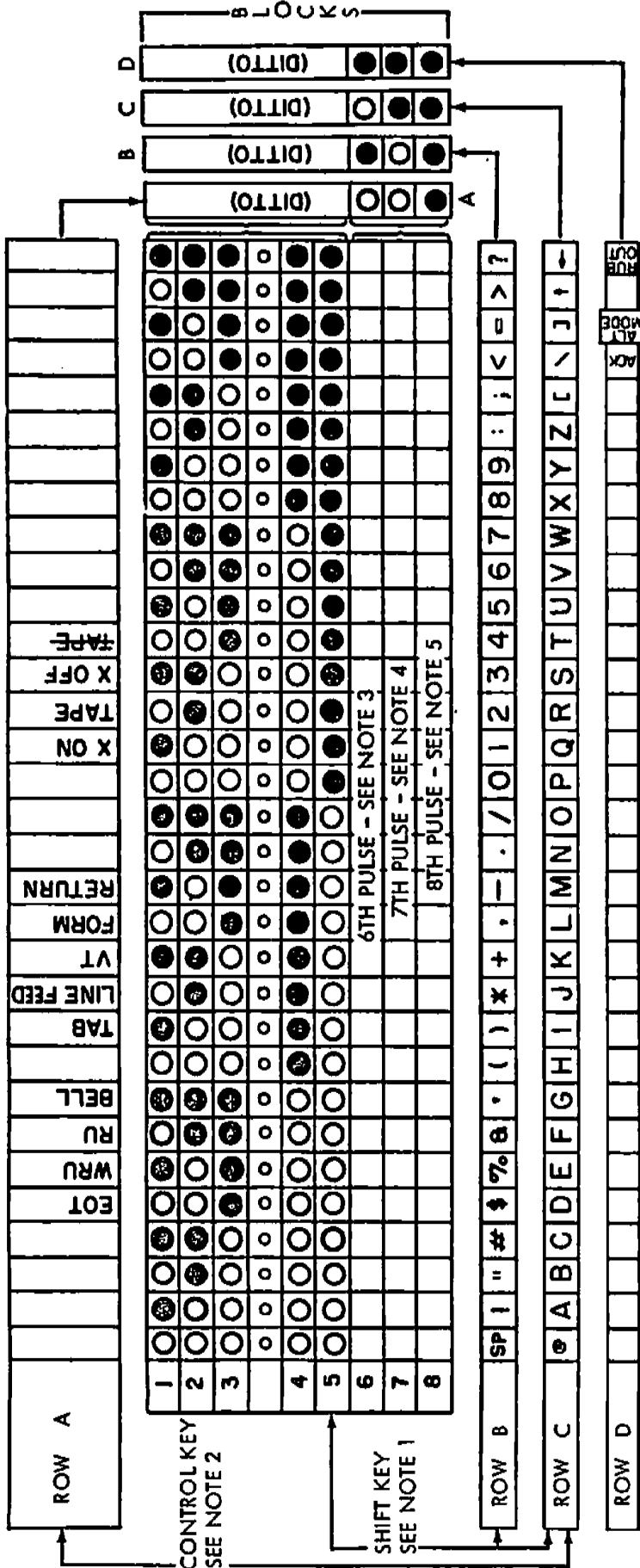

Figure 1 - Eleven Unit Transmission Pattern



**NOTE 5**  
EIGHTH PULSE RESERVED FOR FUTURE USE, AND IS TRANSMITTED AS A MARKING PULSE WHEN NOT USED.

**NOTE 3**  
TYPING ELEMENTS OF 64 CHARACTER PRINTERS ARE POSITIONED BY PULSES 1, 2, 3, 4, 5, AND 7. PAGE PRINTING IS SUPPRESSED WHENEVER PULSES 3, 4, 5, 6, AND 7 ARE MARK (CONTROLS). PULSE 6 IS USED IN DECIDING WHETHER OR NOT PRINTING SHOULD OCCUR, BUT NOT IN DETERMINING WHICH CHARACTER SHOULD BE PRINTED.

**NOTE 1**  
SHIFT KEY CONVERTS #5 INTELLIGENCE LEVEL FROM MARK TO SPACE OR SPACE TO MARK, TO PRINT UPPER KEYTOP GRAPHIC CHARACTERS (SEE FIGURE 3).

**NOTE 2**  
CONTROL KEY CONVERTS #7 INTELLIGENCE LEVEL FROM MARK TO SPACE TO PRODUCE UPPER KEYTOP (NON-PRINTING) CONTROL CHARACTER CODES (SEE FIGURE 3).

**NOTE 4**  
TAPE MACHINES PRINT BLACK WHEN PULSES 6 AND 7 DIFFER. IF PULSES 6 AND 7 ARE BOTH MARK OR SPACE, PRINTING IS RED.

Figure 2 - Code Arrangement

assigned or reserved for future use.

2.02 Figure 2 shows the assignment of characters to the code combinations. These are shown as they would appear in punched paper tape. The continuous row of small holes shows the position of the feed holes. Solid black circles indicate a marking element (hole in tape) while blank circles represent a spacing element (no hole). The main block shows the positions and arrangements for the one through five code levels, while the four smaller blocks (A, B, C, and D), at the right show the four possible combinations of the sixth and seventh levels for the characters indicated by the arrows.

### EIGHTH LEVEL

2.03 The eighth intelligence level is not utilized in this code, but is transmitted - in all instances - as a marking pulse. The principle reason for retaining the eighth level in transmission, is to make possible the handling of messages in codes which require all eight intelligence levels. The terms foreign or native language are used in connection with codes utilizing all eight intelligence levels, to indicate that the character assignments to the code combinations are different from (or foreign to) the data interchange code.

2.04 In addition to the principle reason for retaining the eighth pulse (see Paragraph 2.03), another advantage is provided. Since the eighth pulse immediately precedes the 2-unit stop pulse (Figure 1), it effectively lengthens the stop pulse by one unit. This is desirable, since it permits faster return to synchronization in cases where transmission interference throws receiving machines out of synchronization.

## 3. PRINTING CONTROL

### GENERAL

3.01 The 64 characters, in rows B and C of Figure 2, are all printing characters, and are known as graphics. The assigned characters in rows A and D are control characters and, with the exception of ACK (acknowledge), are not printed.

### PRINT SUPPRESSION

3.02 Print suppression in four-row teletypewriter printing devices is obtained by the following means:

- (1) For characters in row A, the machine recognizes that the sixth and seventh intelligence elements are always spacing, and prevents printing on this indication.

- (2) For the control character RUB-OUT, in row D, the machine recognizes that the character code consists of all marking elements. This is the only character of the entire code having this characteristic.

- (3) For the control character ALT MODE (alternate mode), in row D, printing is suppressed by blinding the printer selector magnet when the ALT MODE key is depressed. Depressing this key also locks the keyboard.

3.03 If the code for any of the remaining characters in row D (even though unassigned) should appear in the system at a printing device, the device would print the character in the corresponding position in row C. The reason for this, is that the sixth intelligence element is not used in the printing operation. Observe that if the sixth intelligence level is omitted from the C and D blocks (Figure 2), the codes for the characters in row C are identical with those of row D. Advantage is taken of this feature, in the situation discussed below, where a printed indication of a control function is needed.

### REVERSE SLANT (\) SYMBOL

3.04 The reverse slant symbol (\) is used for two specific purposes:

- (1) In instances where code conversion takes place between 3-row keyboard and 4-row keyboard systems. When the converter receives a character from one system which has no counterpart in the other system, the converter will operate a reverse slant which prints on the received copy. This indicates to the receiving operator that there is no such character in the receiving system corresponding to the character sent from the originating machine. The reverse slant symbol is used to take the place of both graphics and control characters.

- (2) Where acknowledgment (ACK) of the correct connection of a called station is requested by an inquiry of the form ARE YOU XXX. Answer to the inquiry (if affirmative) will be a reverse slant symbol which will print on the copy of the originating machine. The ACK character (\) will also serve to restart the transmitter, which was stopped to await acknowledgment to the inquiry.

Note: Observe in Figure 2 that the code assigned to the reverse slant symbol (--345-7) is different from the code for ACK (--34567), even though they are both required to print the same symbol. The reason why ACK, a character outside of

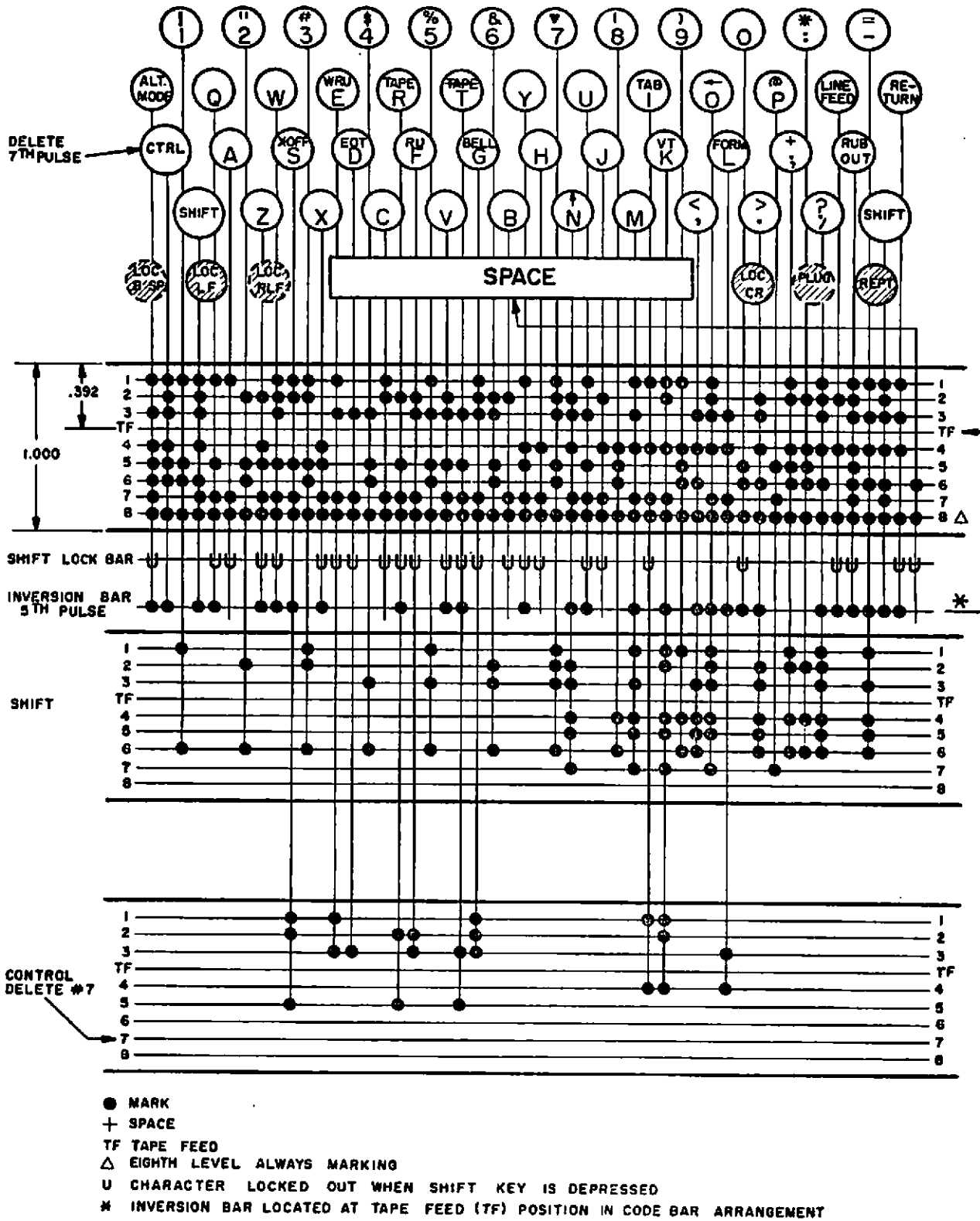

Figure 3 - Keytop Arrangement and Data Interchange Code

the graphic set, prints the reverse slant symbol is discussed in Paragraph 3.03 above.

**4. SHIFT FUNCTIONS**

**GENERAL**

4.01 There are two related but independent shift functions; one is controlled by the SHIFT key, and the other by the CONTROL (CTRL) key. The SHIFT key is used to generate the codes for the graphic symbols which appear on the upper keytop positions. The CONTROL key, on the other hand, is used to generate the codes for the control functions, the characters for which also appear as upper keytop symbols. In both SHIFT and CONTROL cases, the operation is accomplished by holding the key down while the appropriate character key is depressed. A graphic representation of the keyboard, shift functions and punched tape is shown in Figure 3.

**SHIFT KEY**

4.02 The SHIFT key has two different functions for two differently treated groups of upper keytop graphic symbols. Table 1 lists the upper and lower keytop symbols effected by the SHIFT key in the two groups.

4.03 Referring to Figure 3, it can be seen that the codes for the lower keytop symbols, in Group A of Table 1, differ from their corresponding upper keytop symbols in that the 5th intelligence level is marking. To print an upper keytop symbol in Group A, the SHIFT key, when held down, converts the 5th intelligence pulse of

the lower keytop symbol from MARK to SPACE, and results in printing of the corresponding upper keytop symbol.

4.04 In a similar manner, the upper keytop symbols of Group B are printed. For these symbols, however, the SHIFT key, when held down, converts the 5th intelligence pulse of lower keytop symbol from SPACE to MARK (see Figure 3).

4.05 When the SHIFT key is held down, all of the keys which do not print upper graphic symbols are mechanically locked, and cannot be operated. This prevents the possibility of sending false characters which might otherwise be operated.

**CONTROL KEY**

4.06 The CONTROL key operates in a manner which is analogous to that of the SHIFT key (Paragraphs 4.02 through 4.05). The CONTROL key is used to produce the codes for the upper keytop controls shown on Figure 3. Operation of the CONTROL key converts the 7th intelligence level from mark to space. Thus the code for any character in row C of Figure 2, which might be generated by the keyboard, is converted to the corresponding control character in row A. This may be seen by comparing the codes for the control characters with the codes for their corresponding letter characters. Note that the codes are identical, except for the seventh intelligence level, which is marking for all letter characters. For example, if the key for the letter D is struck while the control key is held down, the code generated will be that for EOT (end of transmission). In the same way, the other control characters can be generated

TABLE 1

SHIFT KEY CODE CONVERSION ON #5 LEVEL

GROUP A		SHIFT KEY FUNCTION	GROUP B		SHIFT KEY FUNCTION
KEYTOP SYMBOLS			KEYTOP SYMBOLS		
UPPER	LOWER		UPPER	LOWER	
SPACE	0	SHIFT key, when held down, converts intelligence level #5 from MARK to SPACE, to print upper keytop symbols.	[	K	SHIFT key, when held down, converts intelligence level #5 from SPACE to MARK, to print upper keytop symbols.
!	1		\	L	
"	2		]	M	
#	3		+	N	
\$	4		←	O	
%	5		<	,	
&	6		=	-	
▼	7		>	.	
(	8		?	/	
)	9				
*	:				
+	;				
@	P				

**SECTION 570-011-101**

from the lower symbols by use of the CONTROL key.

**4.07** Because of their frequency of use, separate keys are provided for line feed, carriage return, rub out, and alternate mode, and the CONTROL key is not used in their generation. No means are provided for generating the characters UP CASE and LOW CASE.

**4.08** Since the CONTROL key is not provided with a keyboard locking feature, it is possible, by use of the CONTROL key, to transform any of the codes for characters in rows C and D (Figure 2) to the corresponding codes in rows A and B, respectively. Since there is no automatic guard against this, it is the operator's responsibility not to generate false codes by such operation.

### 33 KEYBOARD

#### PRINCIPLES OF OPERATION

Transmission of messages is accomplished by an operator selectively depressing the keys and spacebar of the keyboard in the same manner as in typing. The downward movement of each key or the spacebar is translated by a codebar mechanism into mechanical arrangement corresponding to the code combination representing the character on the keytop. The mechanical arrangements set up the code combinations in a set of keyboard contacts, and, by parallel output, the code combinations are transmitted to a distributor mechanism. A universal mechanism trips a distributor clutch, and a distributor mechanism then translates the parallel output from the keyboard contacts into corresponding start-stop signal for application to the transmission facilities.

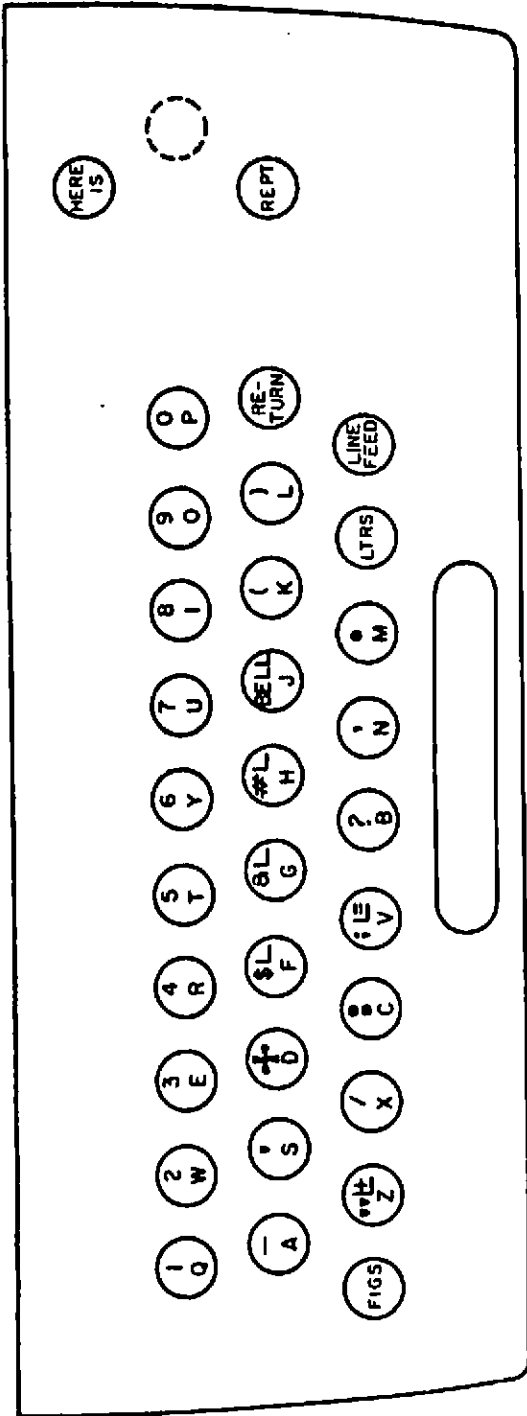

- 32 Keyboard Arrangement

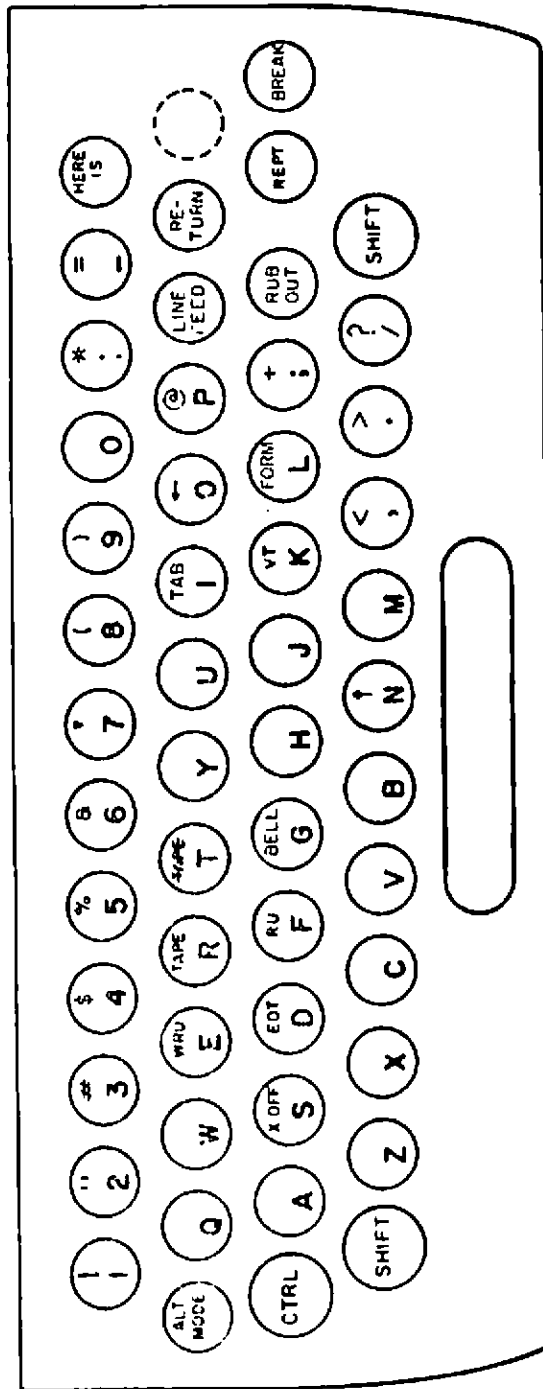

33 Keyboard Arrangement

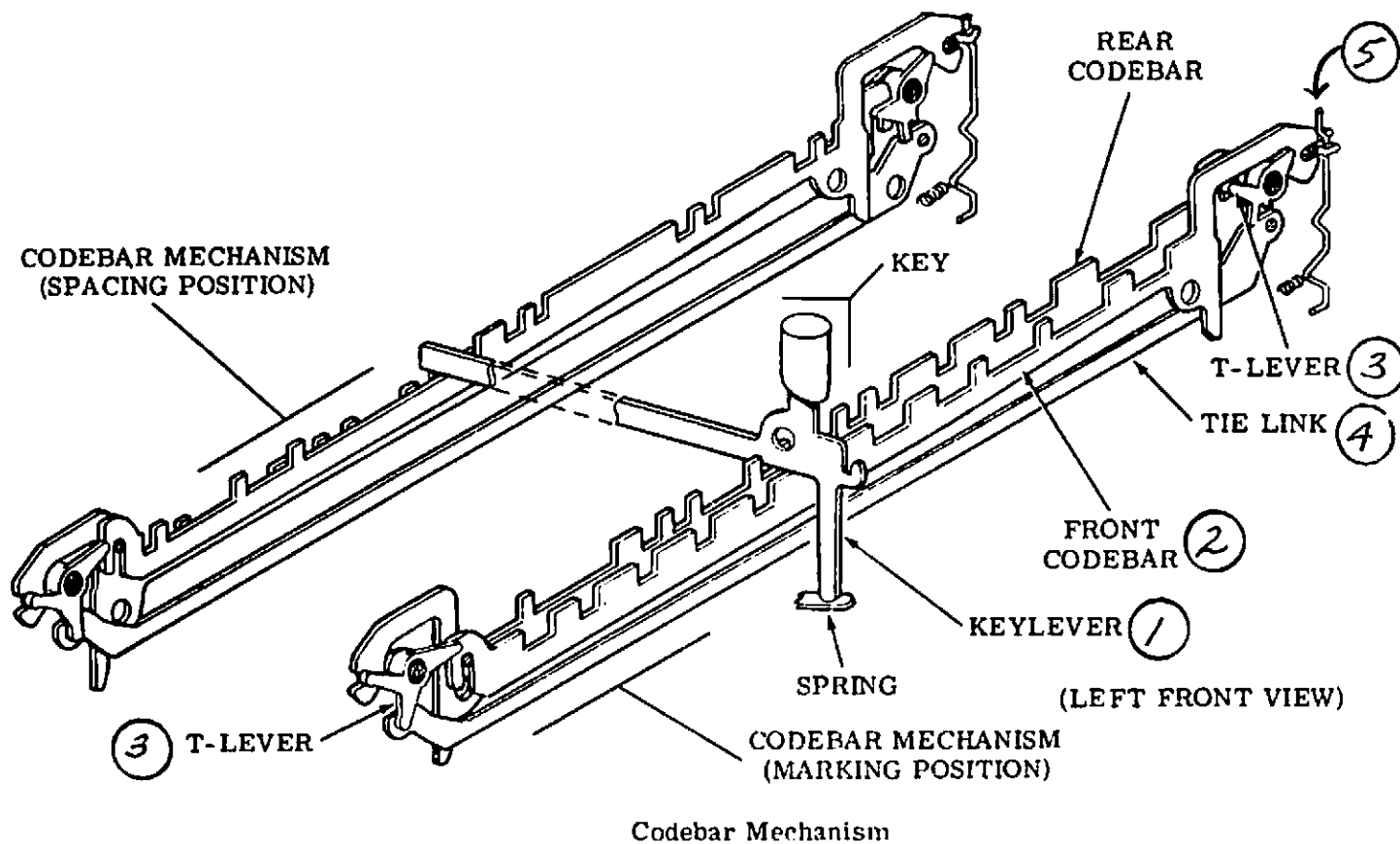

One set of code bars are associated with each code element. Depressing a KEYLEVER (1) engages the driving CODE BAR (2) down. T-LEVERS (3) at each end connected by TIE LINK (4) rotate, guiding the other bar up.

Front code bar down, T-levers rotate clockwise.

Rear code bar down, T-levers rotate counterclockwise.

As T-LEVERS (3) rotate, they will affect the CONTACT WIRES (5). The tine arrangement will prevent simultaneous selection of more than one keylever.

*Light travels at an amazing speed until it hits the human mind*

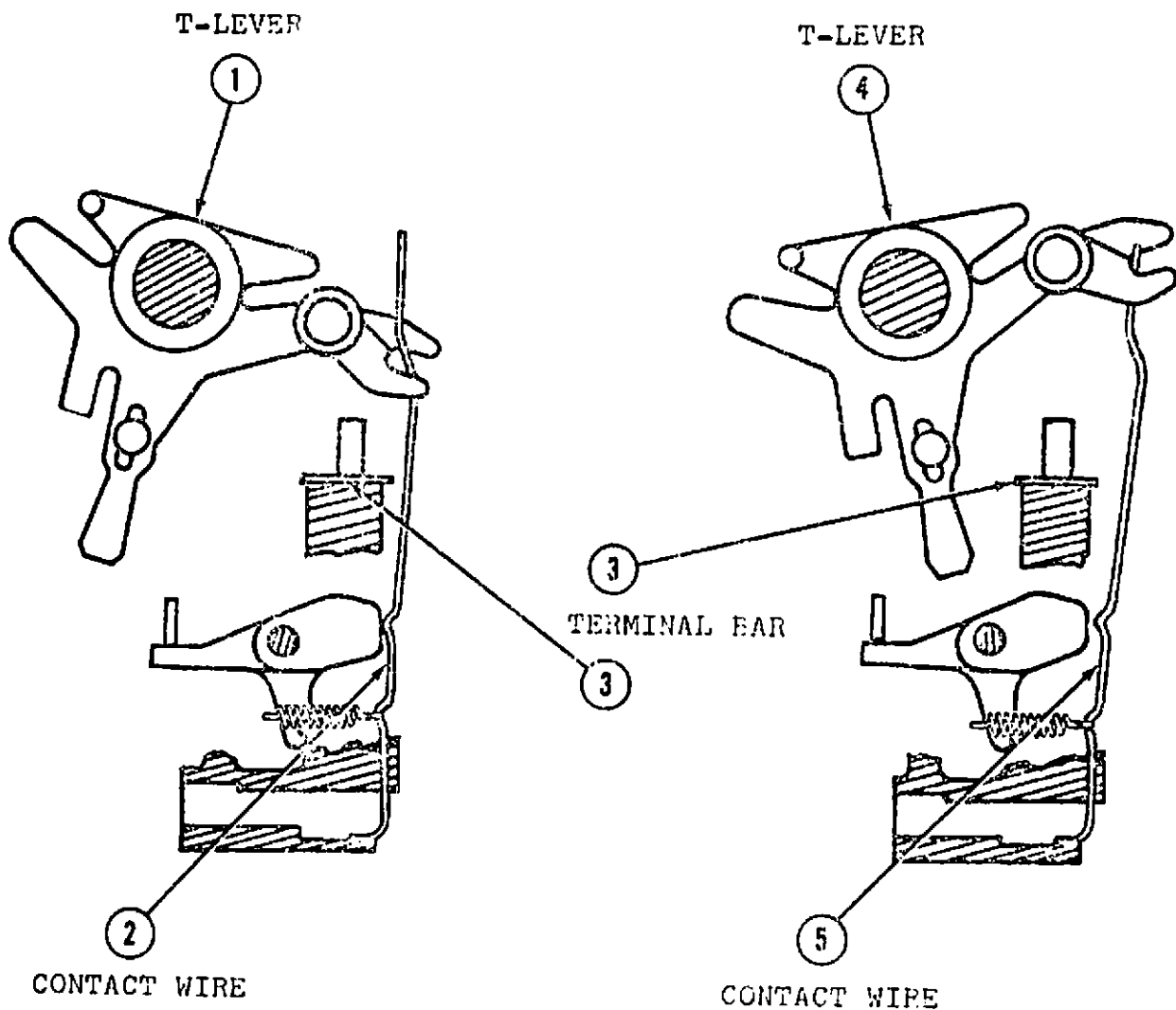

Contact wires rest on the T-levers.

T-LEVERS (1) rotate in clockwise position, permitting CONTACT WIRES (2) to move toward the TERMINAL BAR (3) (marking).

T-LEVERS ROTATE in counterclockwise position move CONTACT WIRES (5) away from TERMINAL BAR (3) (spacing).

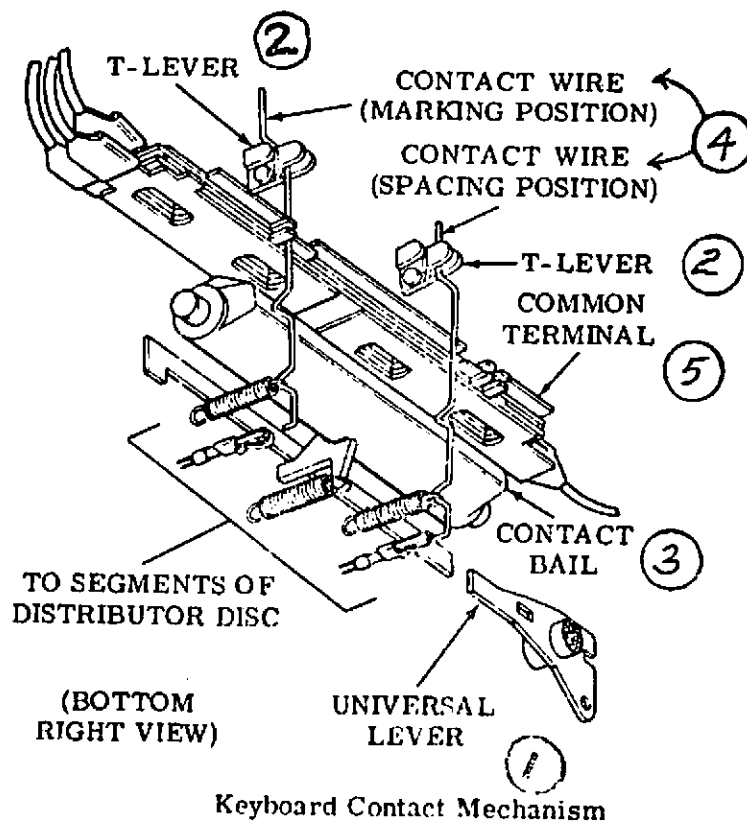

UNIVERSAL LEVER (1) travels up, locking T-LEVERS (2) in position. CONTACT BAIL (3) rotates under spring tension. CONTACT WIRES (4), associated with T-LEVERS (2) in clockwise position, are now permitted to touch TERMINAL BAR (5) completing current paths to distributor disc segments.

As UNIVERSAL LEVER (1) returns down, it pivots CONTACT BAIL (3), lifting all CONTACT WIRES (4) away from TERMINAL BAR (5), returning all code elements to spacing condition.

*One thing worse than a quitter is the fellow who's afraid to begin*

KEYBOARD-DISTRIBUTOR ARRANGEMENT

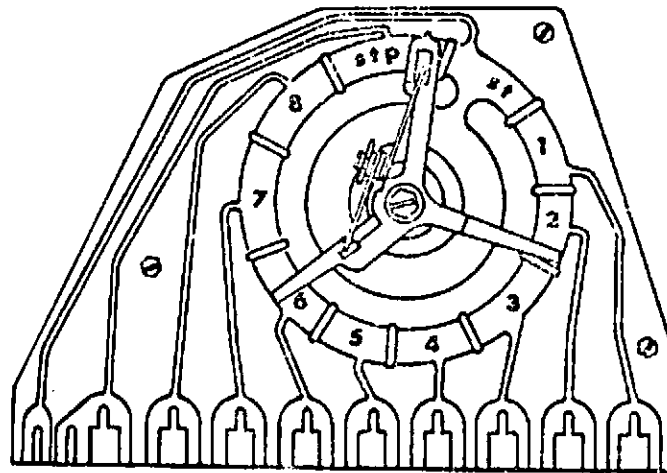

DISTRIBUTOR SEGMENTS ARE WIRED IN PARALLEL WITH KEYBOARD CONTACTS

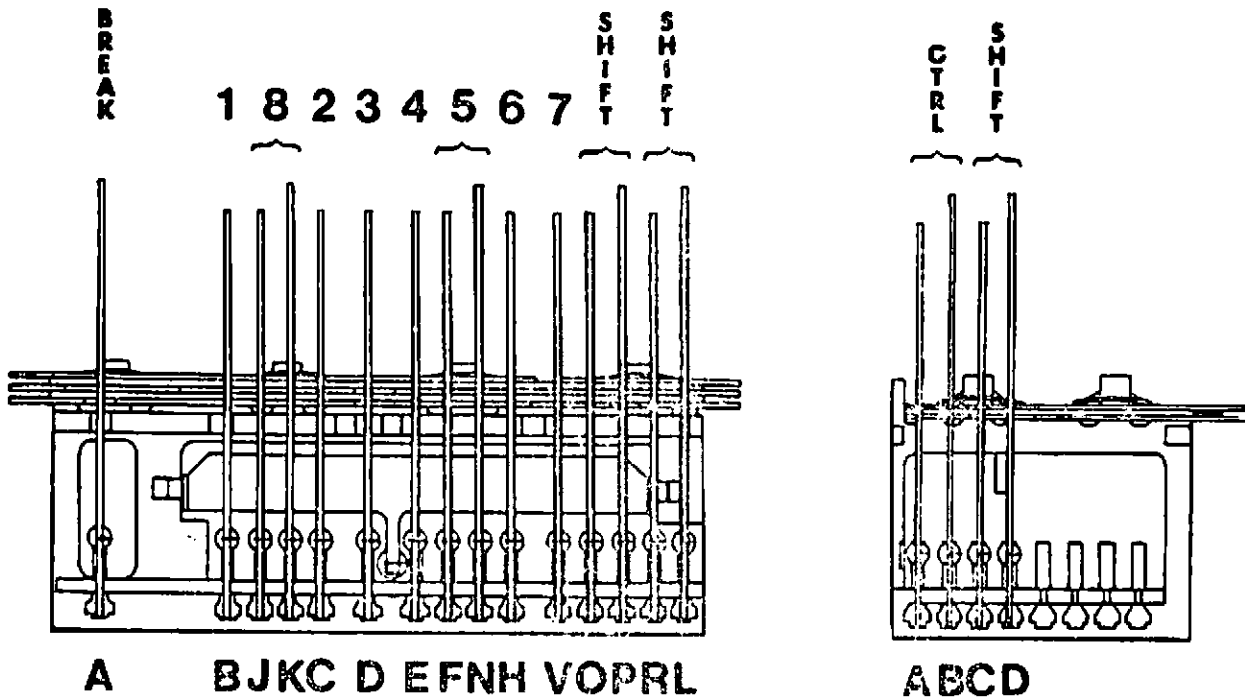

KEYBOARD CONTACTS

RIGHT SIDE

LEFT SIDE

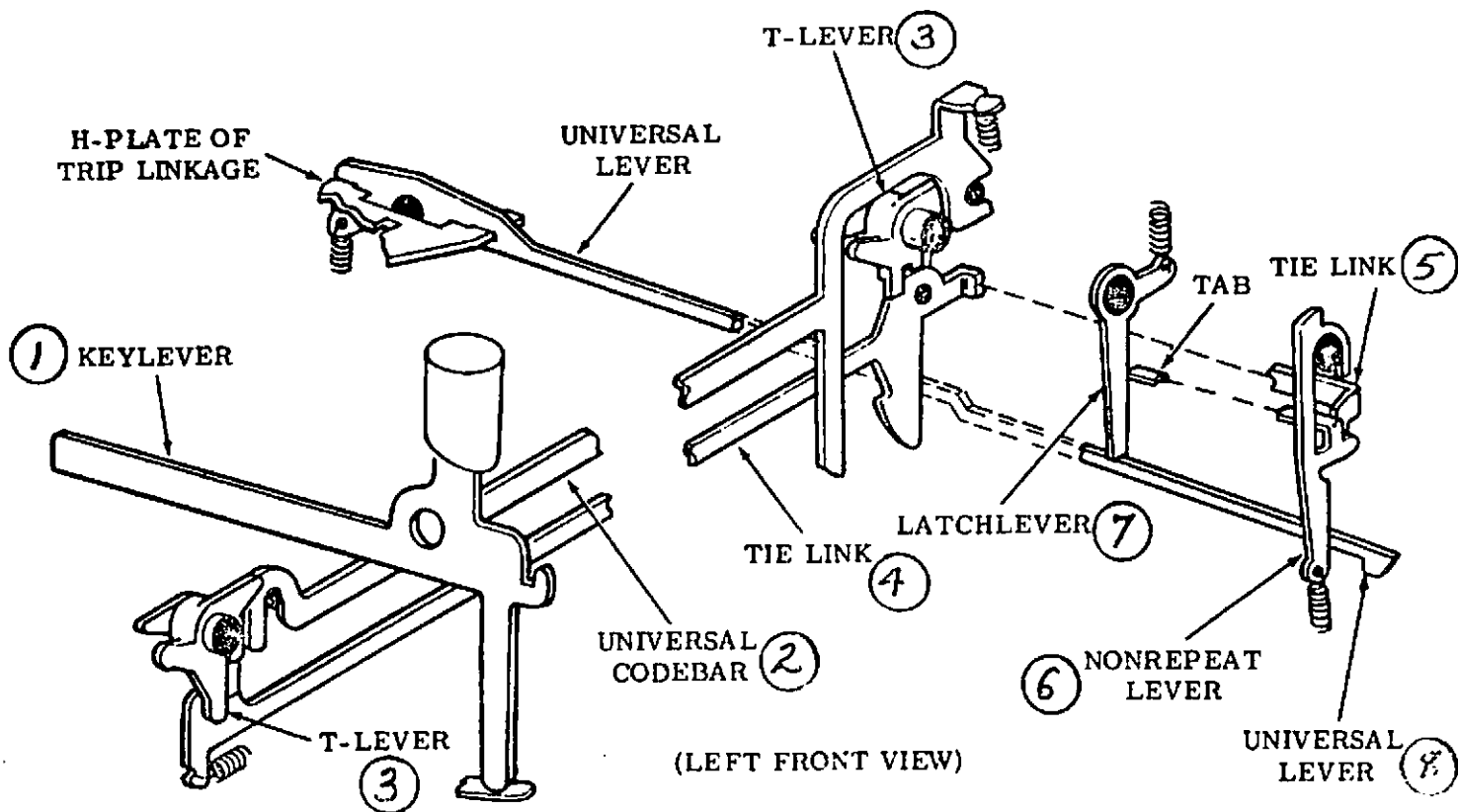

Universal Codebar Mechanism

Single Character Transmission

PRIMARY KEYLEVER (1) drives UNIVERSAL CODE BAR (2) down.

T-LEVERS (3) rotate clockwise moving TIE LINK (4) left. TIE

LINK EXTENSION (5) contacts NON-REPEAT LEVER TAB (6) pivoting

LATCH LEVER (7) left, releasing UNIVERSAL LEVER (8).

UNIVERSAL LEVER (8) travels up lifting NON-REPEAT LEVER TAB (6)

above TIE LINK EXTENSION (5), freeing LATCH LEVER (7) to return

right and latch UNIVERSAL LEVER (8) as it returns down.

*An advance diagnosis  
is worth a lot of post-  
mortems*

# UNIVERSAL LEVER

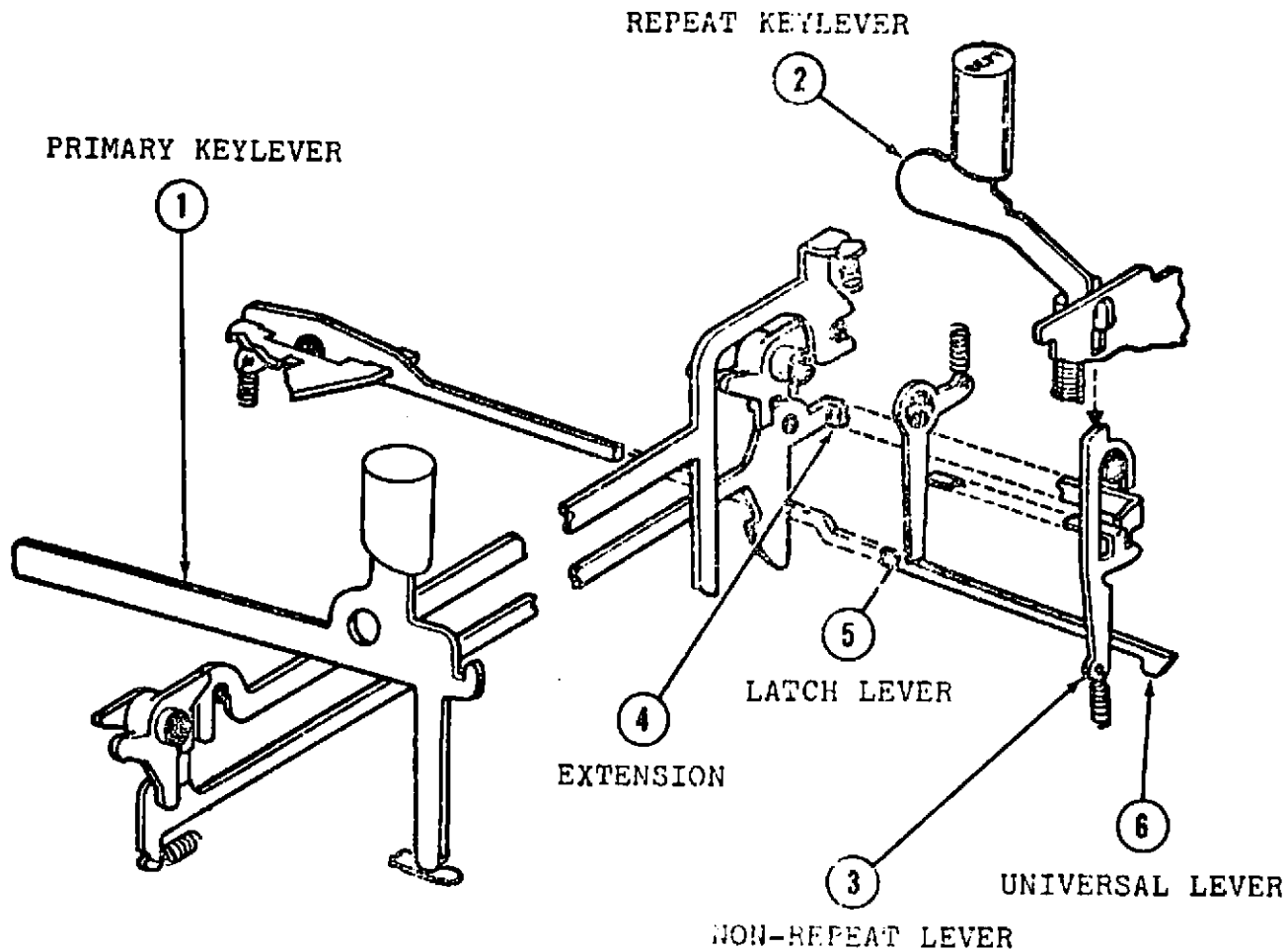

## Repeat Transmission:

Depress PRIMARY KEYLEVER (1) along with repeat KEYLEVER (2).  
NON- REPEAT LEVER (3) is held down, opposite TIE LINK  
EXTENSION (4), opposing UNIVERSAL LEVER (6) lifting action.  
LATCH LEVER (5) remains to the left. UNIVERSAL LEVER (6)  
is not latched.

## H-PLATE AND DISTRIBUTOR CLUTCH

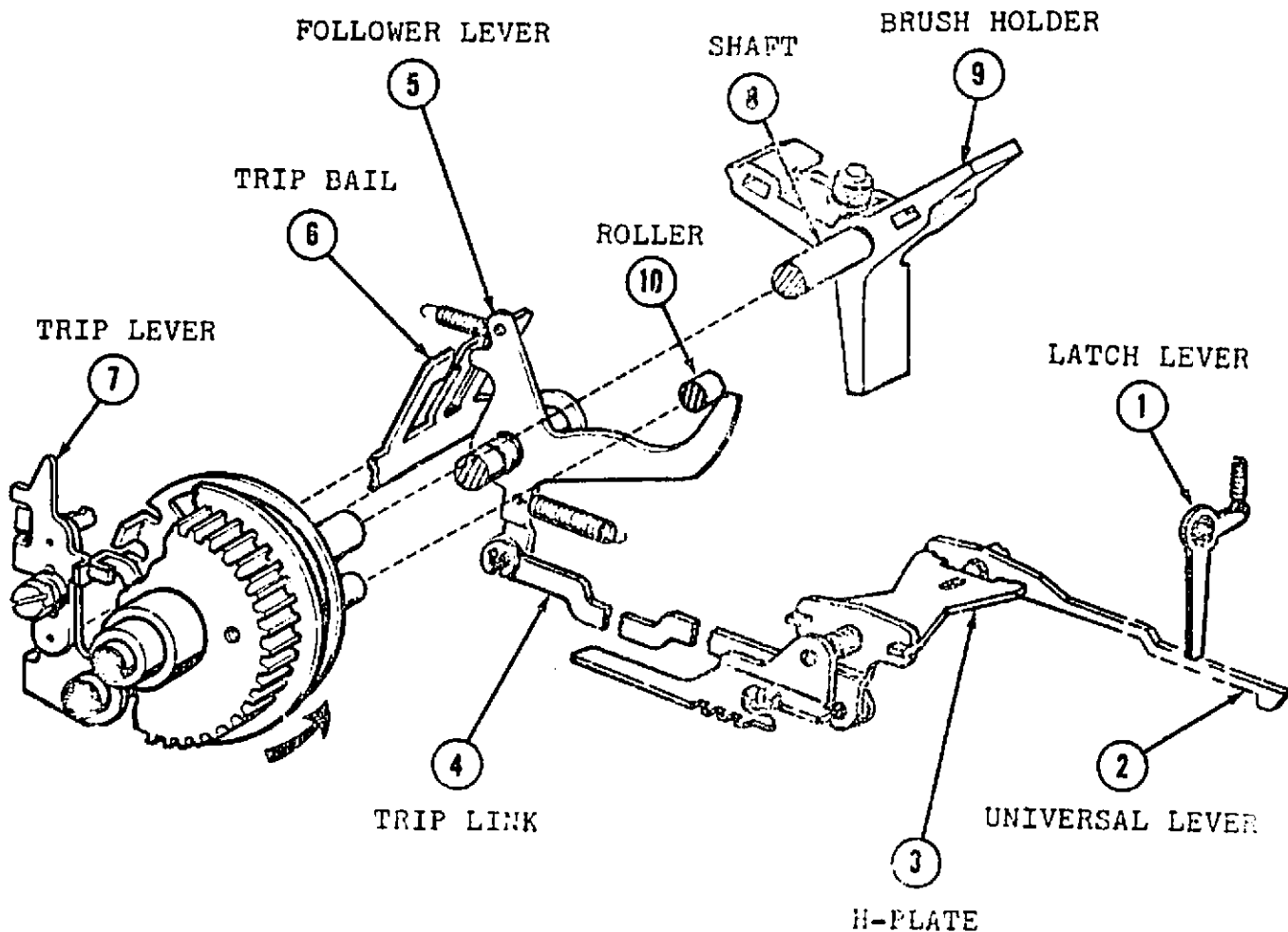

LATCH LEVER (1) pivots left, UNIVERSAL LEVER (2) travels up operating H-PLATE (3). H-PLATE (3) action moves TRIP LINK (4) forward pivoting FOLLOWER LEVER (5) against TRIP BAIL (6) moving it to the rear. Attached TRIP LEVER (7) releases SHOE LEVER and clutch engages. SHAFT (8) and BRUSH HOLDER (9) cycle one revolution.

Mechanism is reset as ROLLER (10) cams FOLLOWER LEVER (5) clockwise. SHOE LEVER strikes TRIP LEVER (7), and clutch disengages.

*Lots of people know a good thing the minute the other fellow sees it*

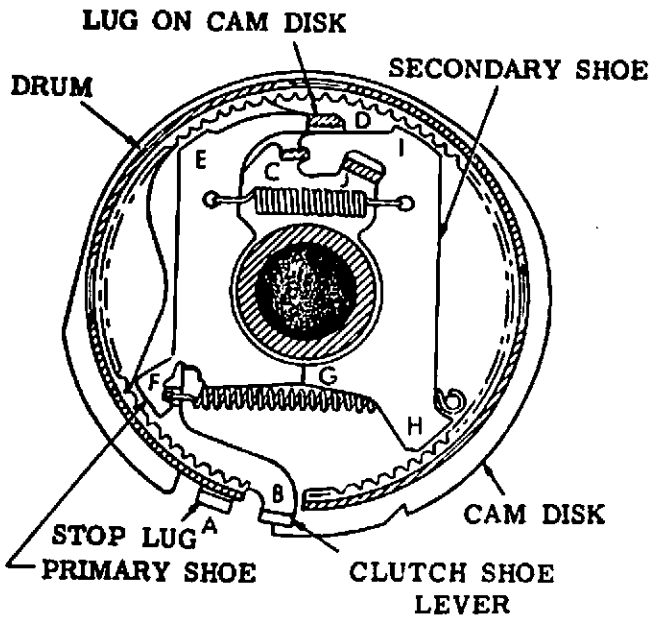

Figure 11 - One Stop Clutch (Disengaged)

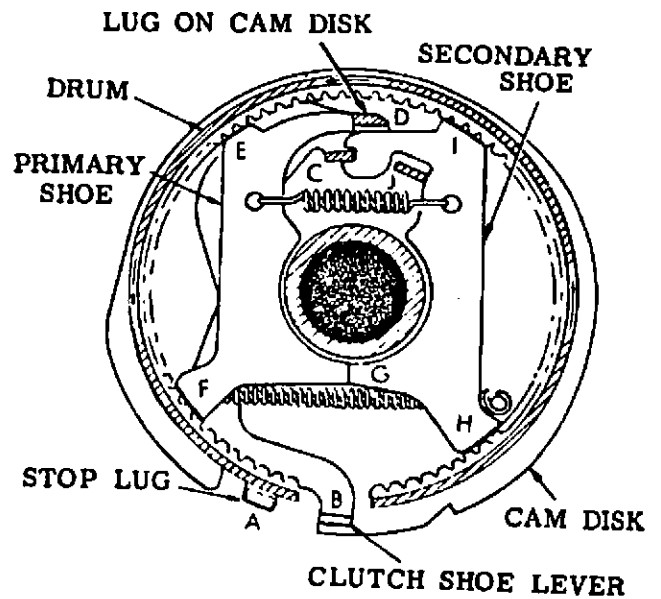
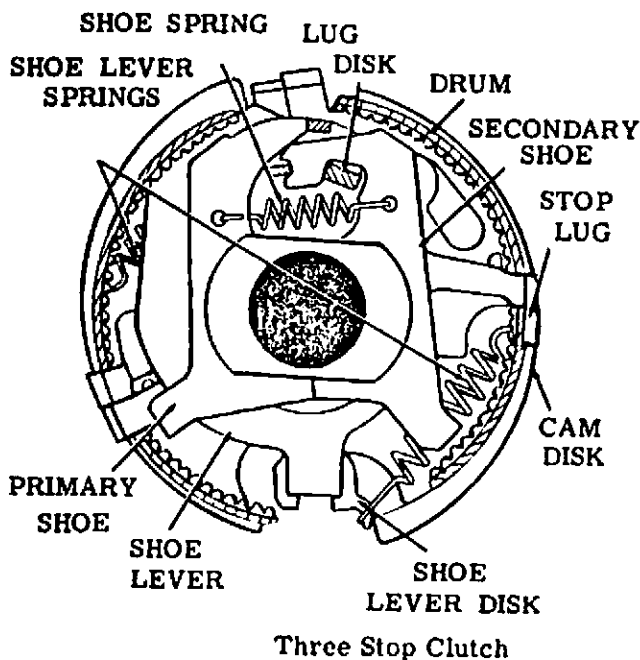

Figure 12 - One Stop Clutch (Engaged)

ONE STOP CLUTCHES (Figs. 11 and 12)

5.05 The clutch drums are attached to and rotate with the main shaft (Fig. 9). In the disengaged position, as shown in Fig. 11, the clutch shoes do not contact the drum, and the shoes and cam disk are held stationary. Engagement is accomplished by moving the stop arm (Fig. 12) toward the rear of the typing unit, away from the clutch, thus releasing stop lug A and the lower end of shoe lever B (Fig. 12). The upper end of lever B pivots about its ear C, which bears against the upper end of the secondary shoe and moves its ear D and the upper end of the primary shoe toward the left until the shoe makes contact with the notched inner surface of the rotating drum at point E. As the drum turns counterclockwise, it drives the primary shoe downward so that it again makes contact with the drum at point F. There, the combined forces acting on the primary shoe cause it to push against the secondary shoe at point G. The lower end of the secondary shoe then bears against the drum at point I. The forces involved are multiplied at each of the preceding steps. The aggregate force is applied through the shoes to the lug J on the clutch cam disk, and the disk and attached cam turn in unison with the drum.

5.06 Disengagement is effected when the lower end of shoe lever B strikes the stop arm. Lug A and the lower end of the shoe lever are brought together (Fig. 11), and the upper end of lever B pivots about its ear C and allows its other ear D to move toward the right. The upper spring then pulls the two shoes together and away from the drum. The latch lever seats in the indent in the cam disk, and the cam is held in its stop position until the clutch is again engaged.



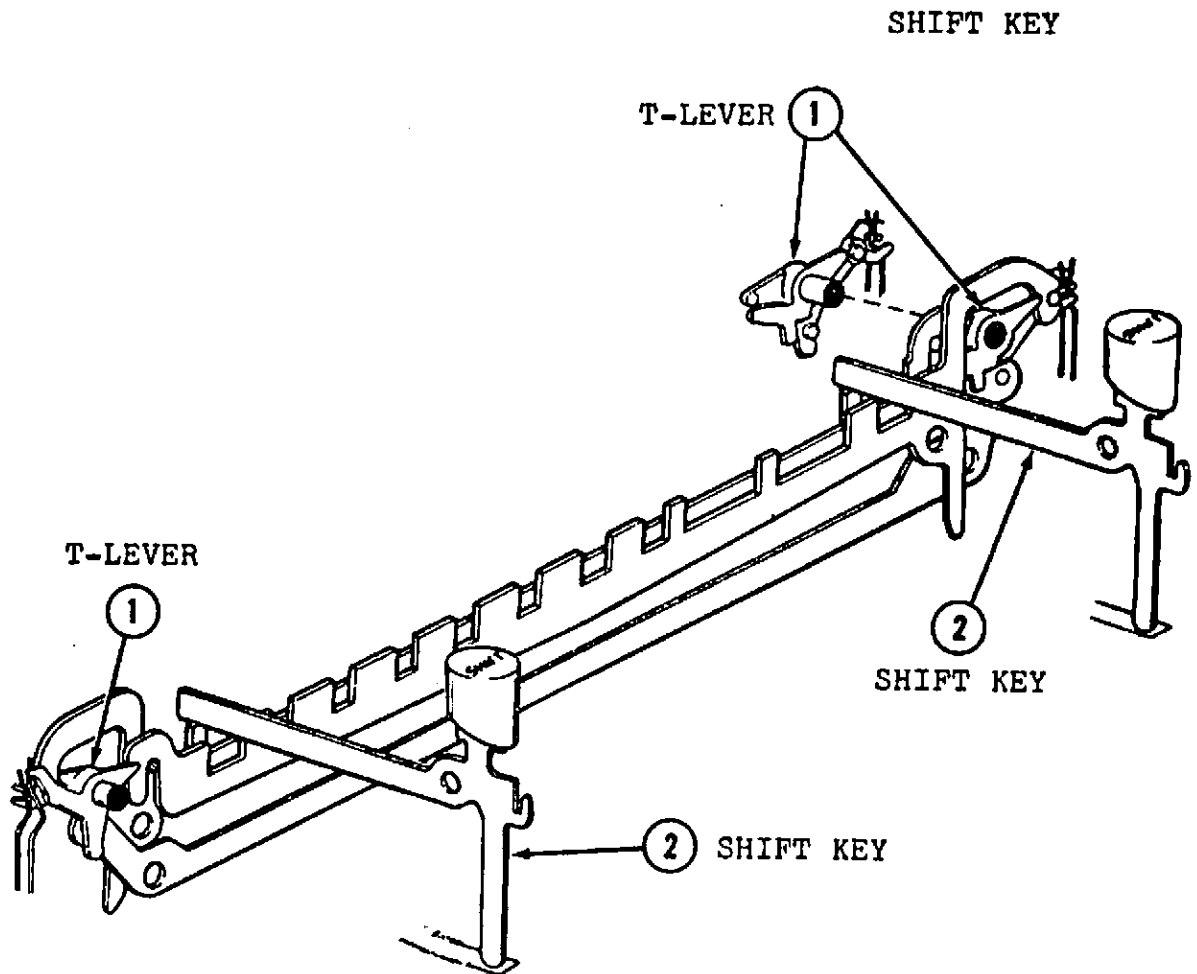

The SHIFT KEY is used to generate PRINTING code combinations for characters appearing on upper keytops.

Three (3) double-headed T-LEVERS (1) are operated as SHIFT KEY (2) is depressed.

Two (2) contact wires are positioned on each T-Lever, altering the (No. 5) logic circuit from a (mark to space) or (space to mark).

The (No. 8) logic circuit is inverted simultaneously to meet even parity.

KEYBOARD CONTACTS

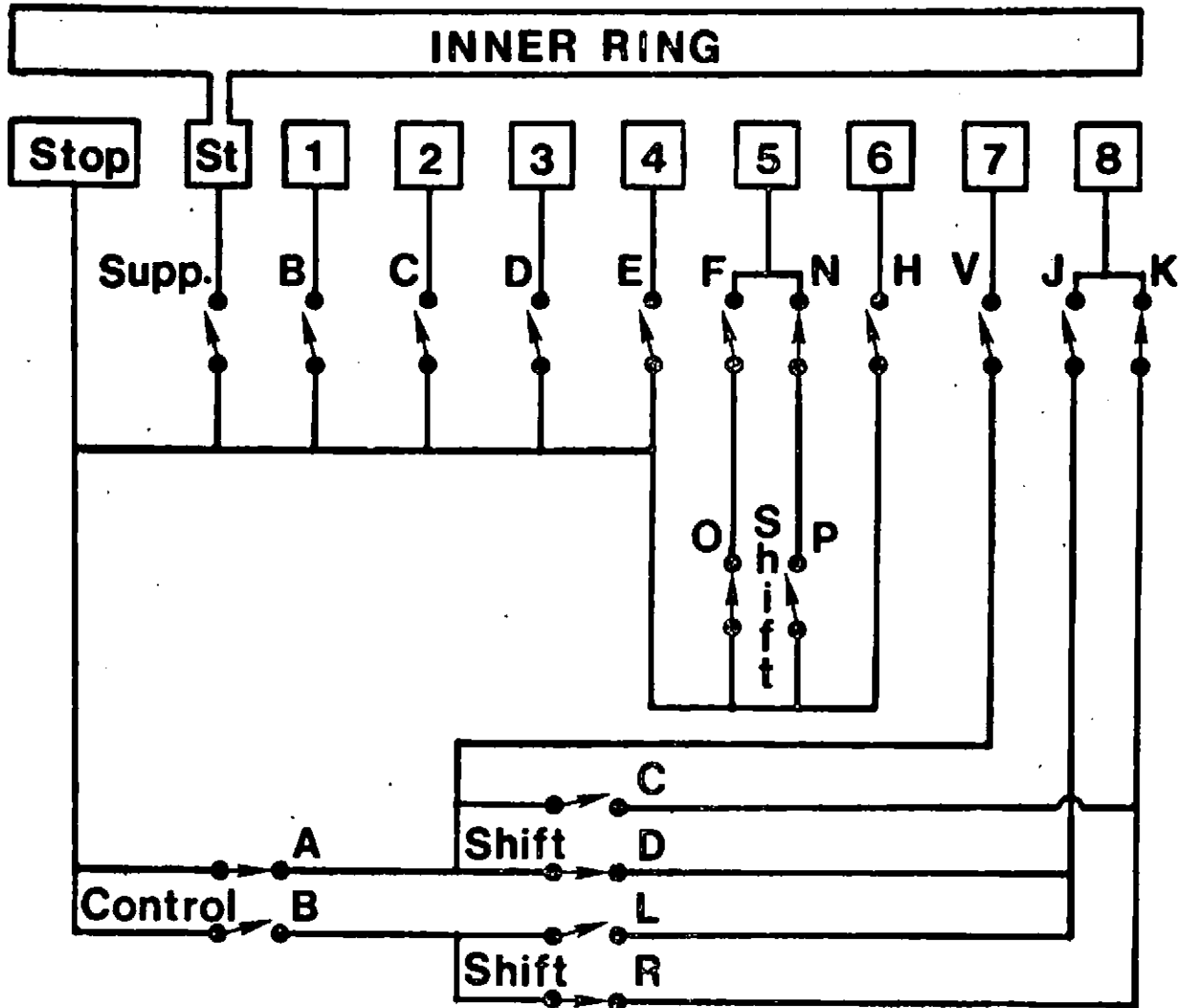

CODE CONTACTS SHOWN WITH T-LEVERS SPACING.

SHIFT AND CONTROL KEY CONTACTS SHOWN UNOPERATED.

Depression of SHIFT KEY will operate contacts: O, D, R, (open); P, C, L, (closed).

Depression of CONTROL KEY will operate contact A (open), contact B (closed).

## CONTROL KEY

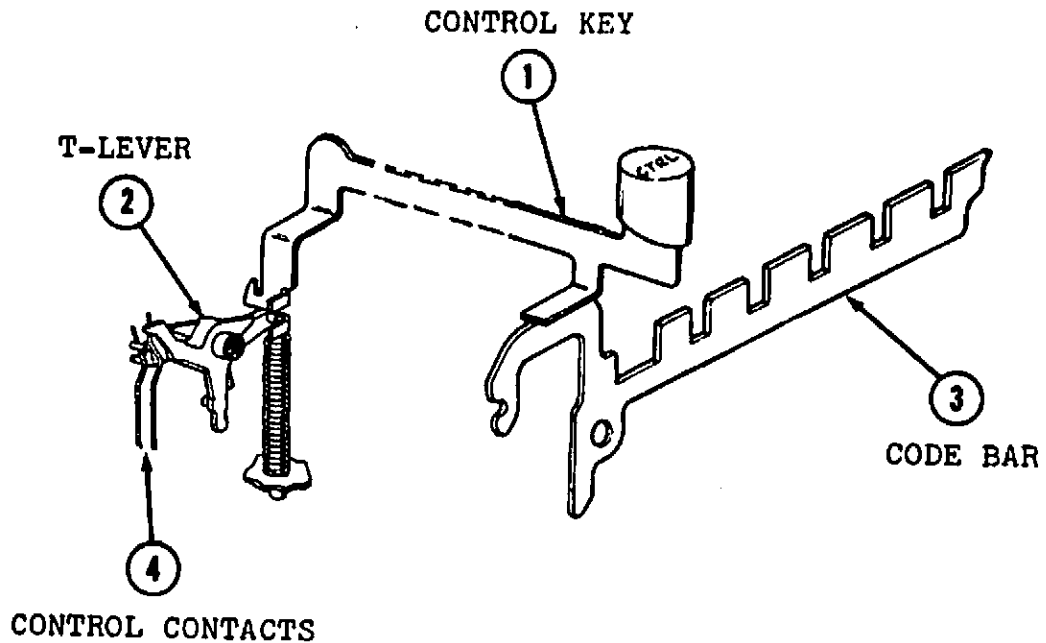

The CONTROL KEY is used to generate NON-PRINTING CONTROL code combinations appearing on upper keytops, and also various other control combinations not appearing on keytops.

Depression of CONTROL KEY (1) operates one (1) double-headed T-LEVER (2) and the rear bar of (No. 6) CODE BAR SET (3). Two (2) CONTROL CONTACTS (4) are positioned to invert the (No. 7) code element from (mark to space). No. 6 code element is driven spacing. The (No. 8) logic circuit is inverted simultaneously to meet even parity.

Depression of CONTROL and SHIFT KEYS simultaneously with primary keys, K, L, M, O, P, will provide special NON-PRINTING CONTROL FUNCTIONS.

*The customer is always right, especially if you are the customer*

PARALLEL OUTPUT CIRCUITS  
(ASR)

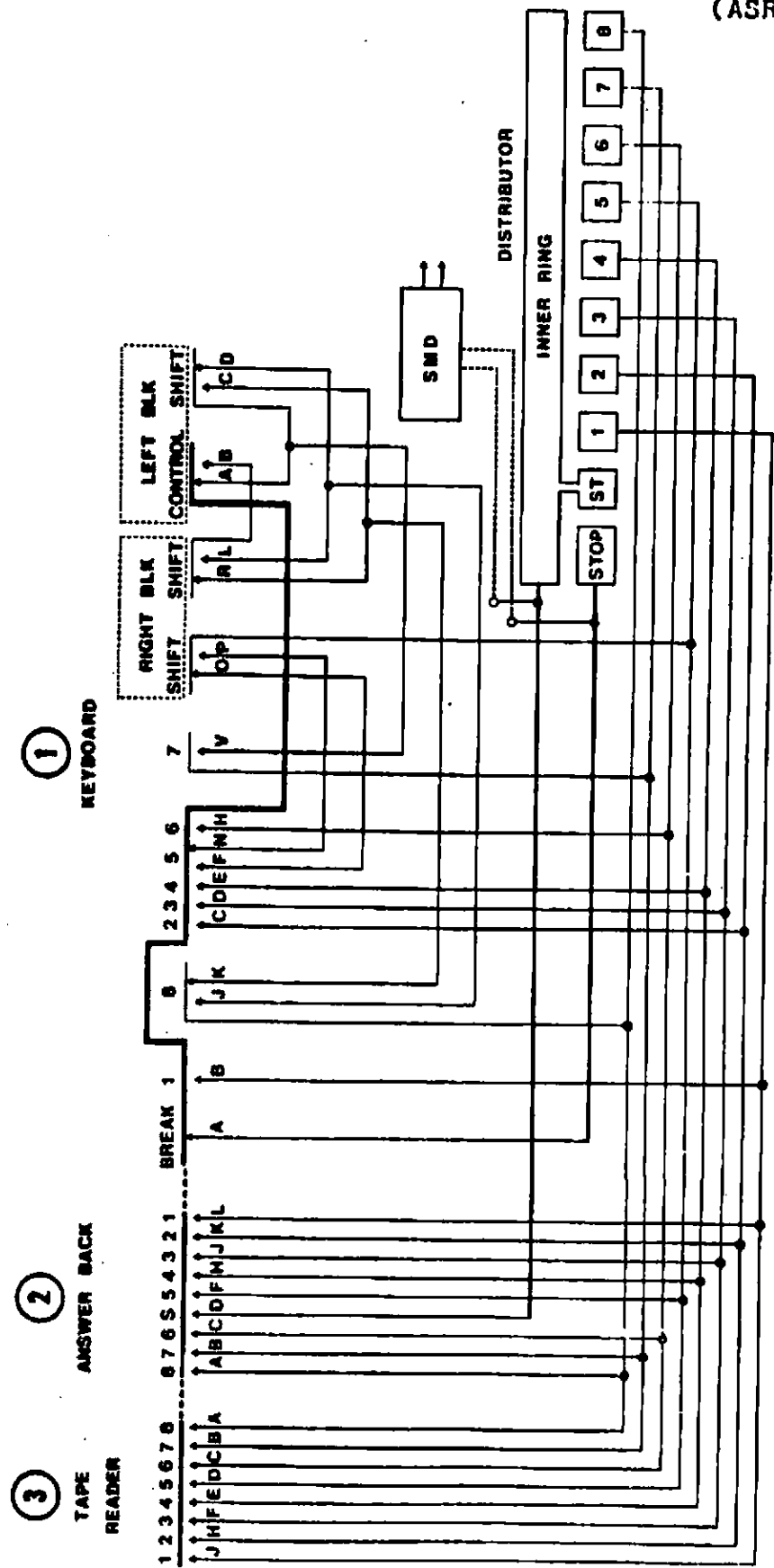

The parallel output circuits are routed through the set CALL CONTROL UNIT, and terminate at the set DISTRIBUTOR.

- ① KEYBOARD--plug #7
- ② ANSWER BACK--plug #8
- ③ TAPE READER--plug #6



## MODEL 33 KEYBOARD

See the following General System Practices for related keyboard information:

- A. 574-121-100 -- Principles of Operation
- B. 574-121-700 -- Adjustments
- C. 574-121-701 -- Lubrication
- D. 574-121-702 -- Disassembly and Reassembly
- E. 574-121-800 -- Parts

## TYPING UNIT

3.05 The typing unit receives start-stop signals from the call control unit and uses them to control mechanical motions which print the messages, perform functions, and, in the case of the ASR, perforate tape.

3.06 The principal components of the typing unit include the following:

(a) A main shaft which receives motion from the drive parts and distributes it to the various mechanisms through three (four) internal expansion clutches.

Note: Friction feed typing units have three clutches. Sprocket feed typing units have four clutches.

(b) A selector mechanism which translates the start-stop signals to corresponding mechanical arrangements that control a codebar mechanism. A range finder permits the selector to be adjusted so as to sample the signals at the most favorable time.

(c) A codebar mechanism which controls printing, functions, and, in the case of the ASR, tape perforation.

(d) A printing carriage which prints the messages on the paper. The characters are embossed on the cylindrical surface of a typewheel. The typewheel is positioned rotationally and vertically to select the proper characters, and a hammer drives it and an inked ribbon against the paper to effect printing. A ribbon mechanism feeds the ribbon and reverses its direction when one of its spools is depleted.

(e) A function mechanism which enables the typing unit to perform functions supplementary to printing. The standard functions are "space," "carriage return," "line feed,"

"blank," "bell," and (for the 32 typing unit) "letters" (lower case) and "figures" (upper case).

Note: In addition, sprocket feed typing units have the function "form-out."

(f) A paper feed mechanism which positions paper or forms vertically so that the characters are properly located in lines. A platen feeds the paper or forms. A knob permits manual feeding. The mechanism can be adjusted for single or double line feed.

(g) A spacing mechanism which positions the carriage so that the characters are properly located horizontally on the paper. It moves the carriage, which rides on rollers, by a spacing belt. It returns the carriage to the left margin by a carriage return spring. The carriage is pneumatically stopped without shock by a piston and dashpot cylinder arrangement.

(h) A disc and brush type distributor mechanism which converts the positions of the keyboard contacts (3.01 (c)) to start-stop signals for application to transmission facilities.

Note: An answer-back mechanism, which is an optional accessory, often is used in conjunction with the distributor. It will automatically transmit a sequence of characters for station identification. It may be coded to transmit any sequence of up to 20 characters and may be actuated locally or remotely.

Few things are as bad  
as enthusiastic ignorance

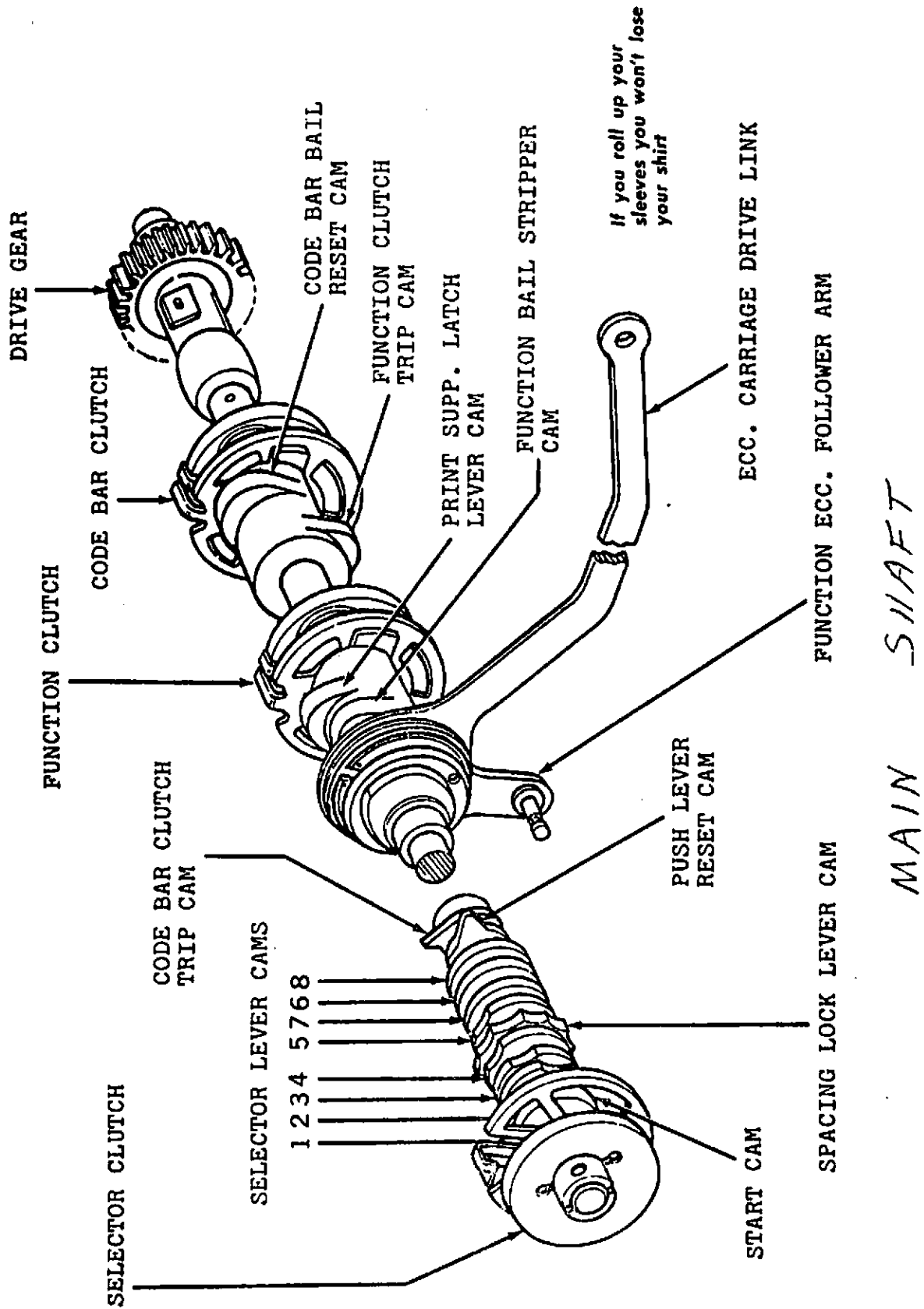

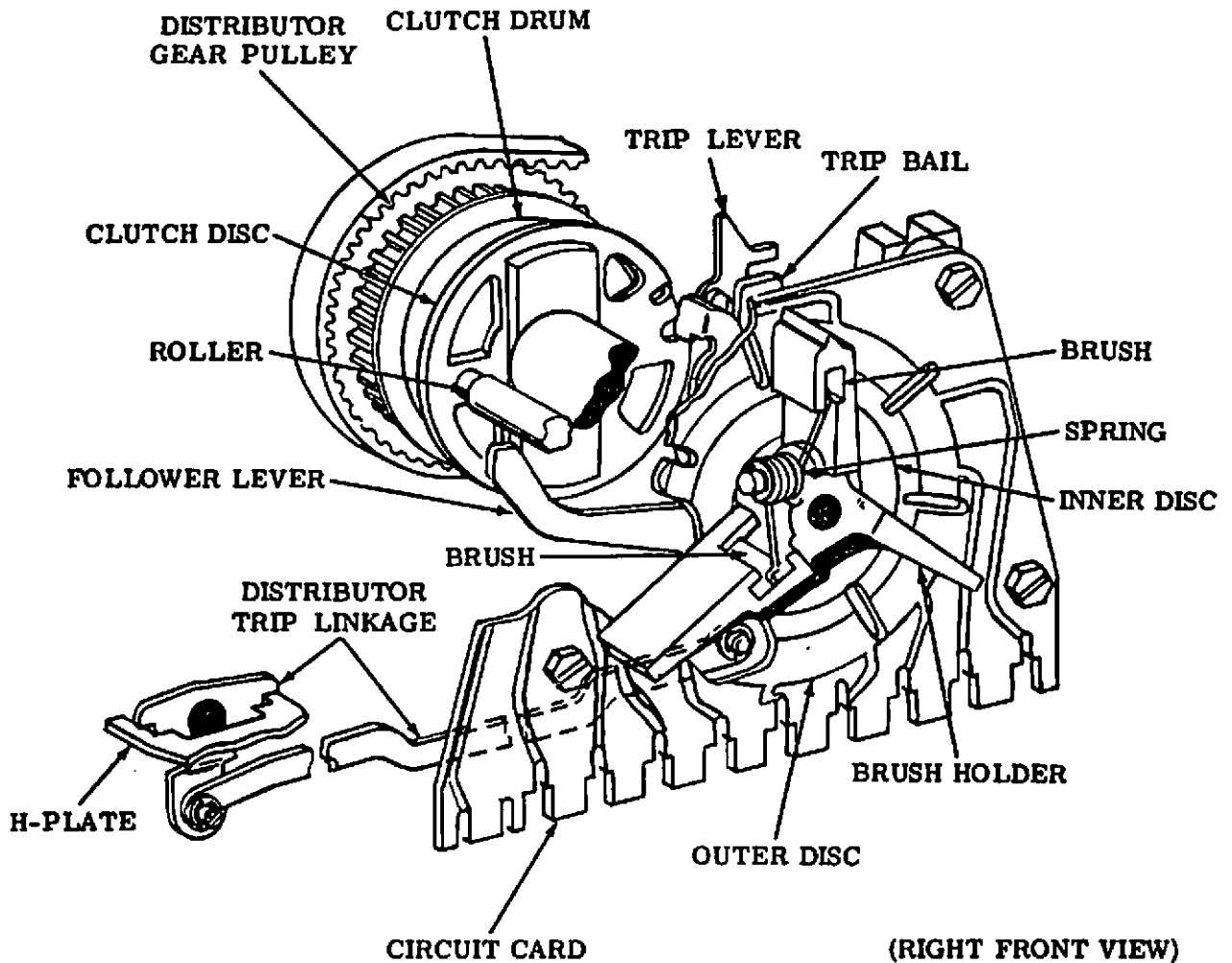

Distributor Mechanism

2.12 The distributor mechanism receives the parallel output of the keyboard contacts which have been mechanically arranged into code combinations and converts it to start-stop signals and applies them to the signal line. The mechanism receives rotary motion from a distributor gear pulley attached to the drum of a distributor clutch. The clutch disc is connected to a distributor shaft. A brush holder mounted on the shaft carries two carbon brushes which are electrically connected by a spring and ride on an inner and outer disc, respectively. The discs are part of a printed circuit card that provides facilities for interconnecting the distributor with other apparatus. The outer disc is divided into segments—ten for 33 typing units, seven for 32 typing units. The segments correspond to the elements of the teletypewriter code

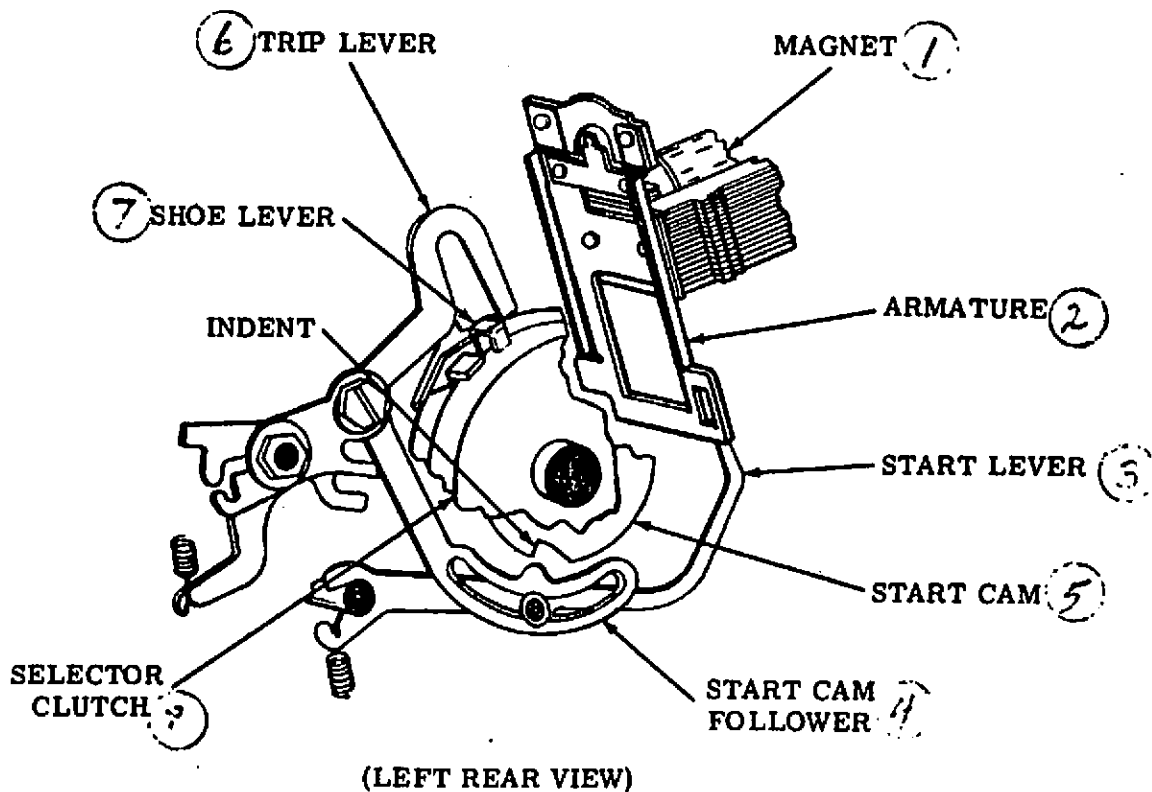

Selector Trip Mechanism

Spacing start pulse is received. MAGNET COIL (1) de-energizes, ARMATURE (2) moves left unattracted. START LEVER (3) travels up carrying associated START CAM FOLLOWER LEVER (4) into START CAM (5) indent. Attached TRIP LEVER (6) moves up freeing CLUTCH (8), engaging SHOE LEVER (7), engaging CLUTCH (8). As CLUTCH (8) begins to rotate, START CAM FOLLOWER LEVER (4) rides out of START CAM (5) indent, moving START LEVER (3) down away from ARMATURE (2). TRIP LEVER (6) returns into path of SHOE LEVER (7).

*Be interested in the future; you'll spend the rest of your life there*

## SAMPLING OF CODE ELEMENTS

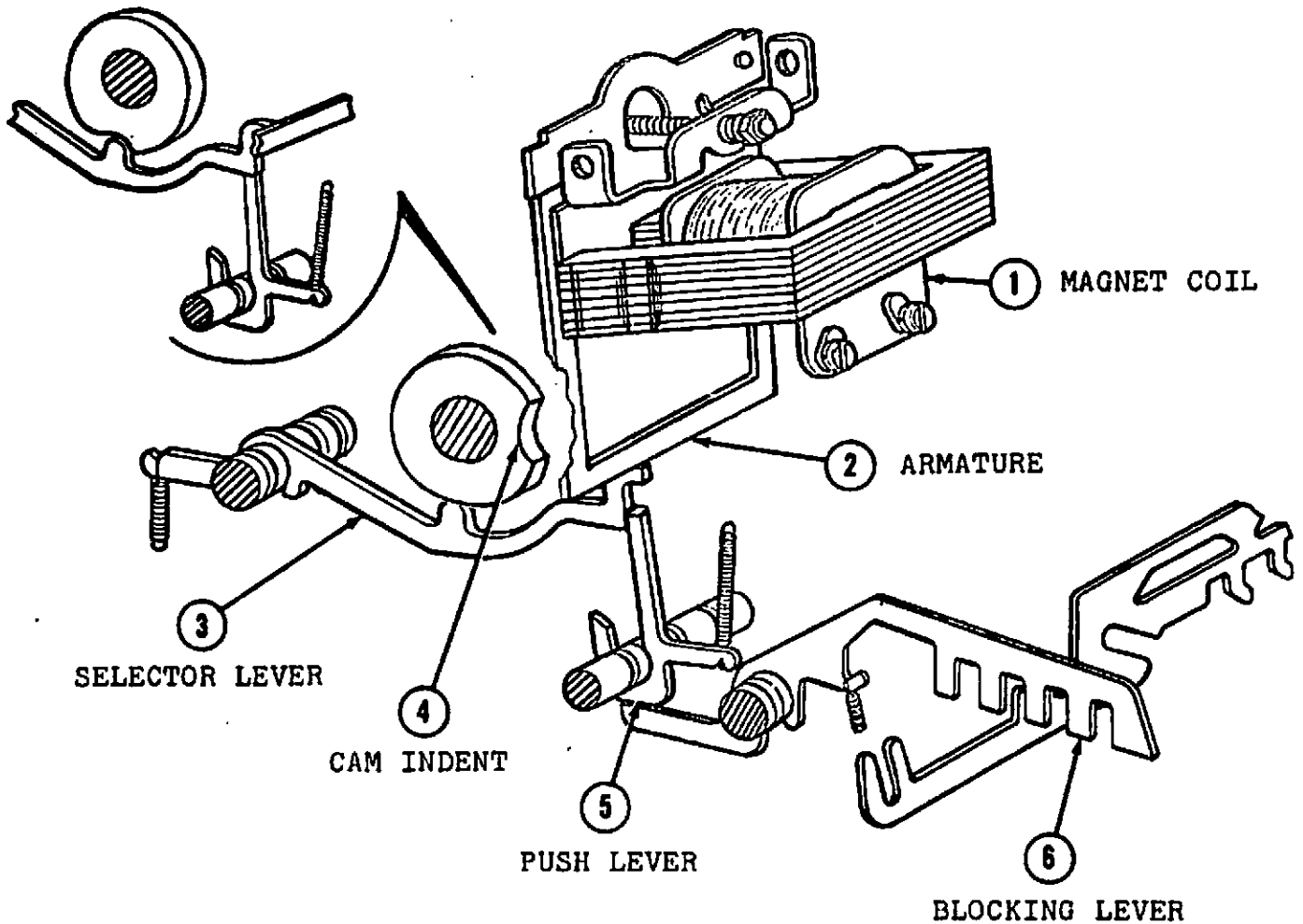

### Marking Condition ( Current):

MAGNET COIL (1) energizes, ARMATURE (2) is attracted. SELECTOR LEVER (3) rides into CAM INDENT (4), PUSH LEVER (5) undertravels SELECTOR LEVER (3) (selected condition). SELECTOR LEVER (3) rides out of indent driving PUSH LEVER (5) down, pivoting BLOCKING LEVER (6) up.

### Spacing Condition (No-Current)

MAGNET COIL (1) de-energizes, ARMATURE (2) moves to rear, blocking SELECTOR LEVER (3) from entering CAM indent (4). PUSH LEVER (5) fails to undertravel SELECTOR LEVER (3) (unselected condition). BLOCKING LEVER (6) remains down.

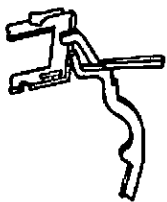

(SPACING POSITION DURING SAMPLING INTERVAL)

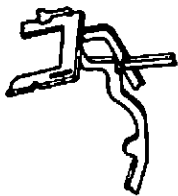

(MARKING POSITION DURING SAMPLING INTERVAL)

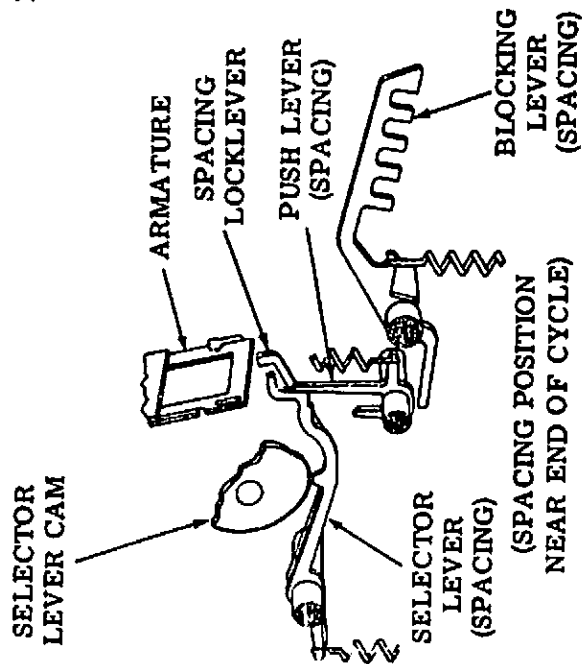

(LEFT FRONT VIEW)

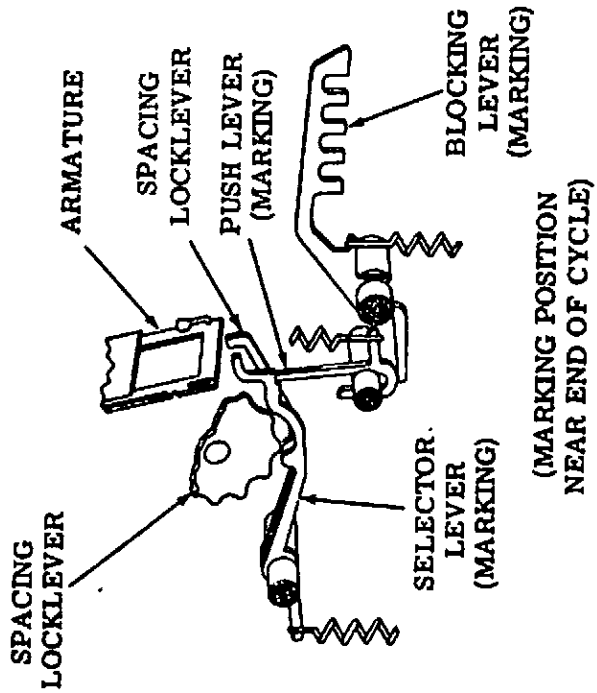

(MARKING POSITION NEAR END OF CYCLE)

Selector Mechanism

## SPACING LOCK LEVER

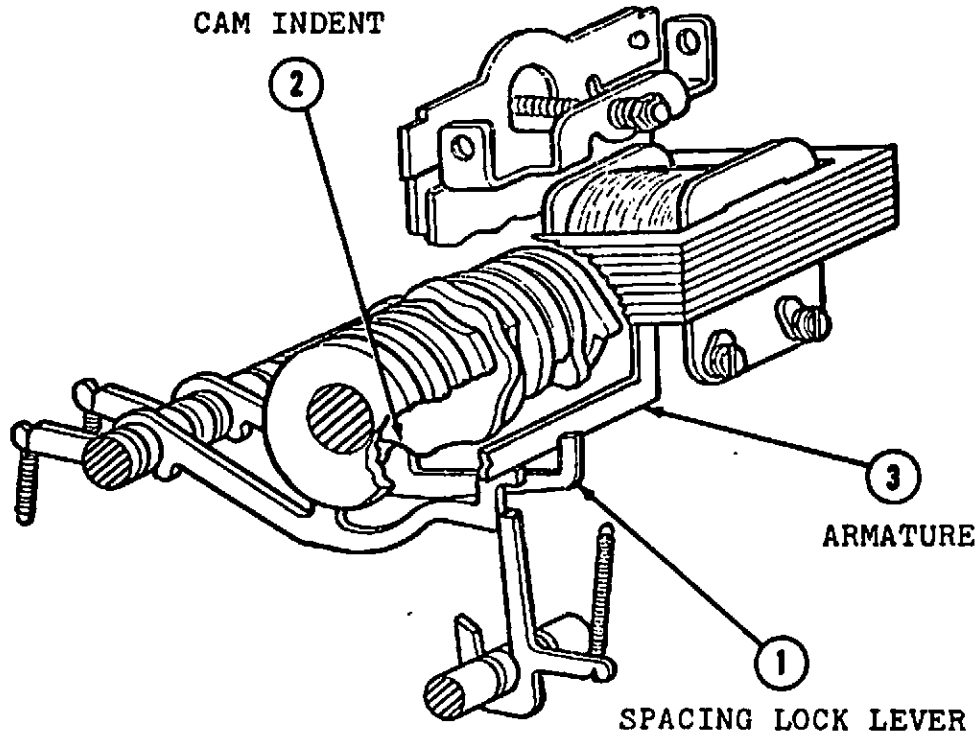

When sampling a spacing code element, the SPACING LOCK LEVER (1) rides into CAM INDENT (2), locking the ARMATURE (3) in unattracted position.

When sampling a marking code element, the ARMATURE (3) blocks the SPACING LOCK LEVER (1) from entering into its CAM INDENT (2). The selector lever action will lock the armature in attracted position.

## STRIPPER BAIL

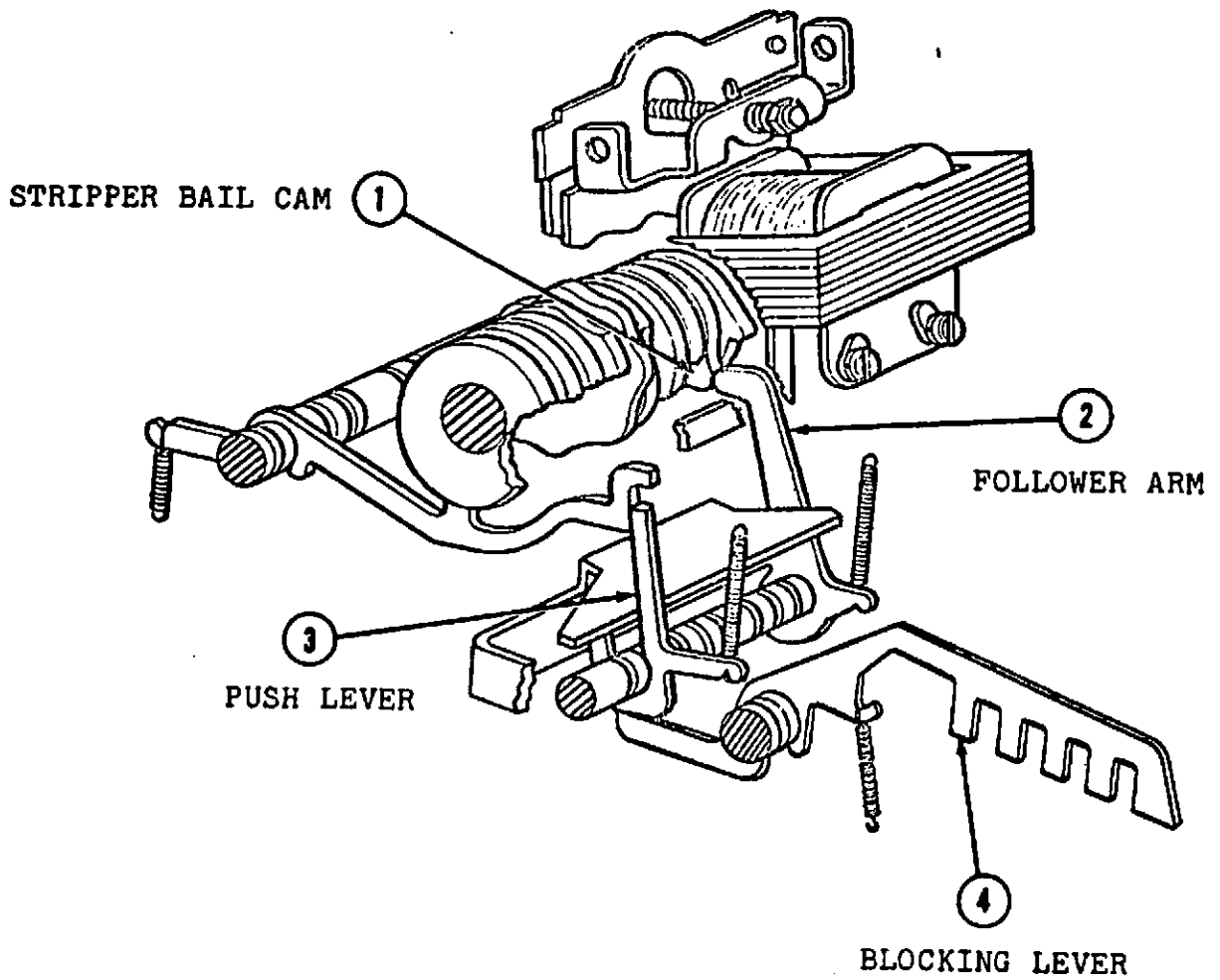

STRIPPER BAIL CAM (1) operates STRIPPER BAIL FOLLOWER ARM (2),  
moving PUSH LEVERS (3) forward.

Previously selected PUSH LEVERS (3) move up, freeing their  
BLOCKING LEVERS (4) to pivot down.

# RANGE FINDER

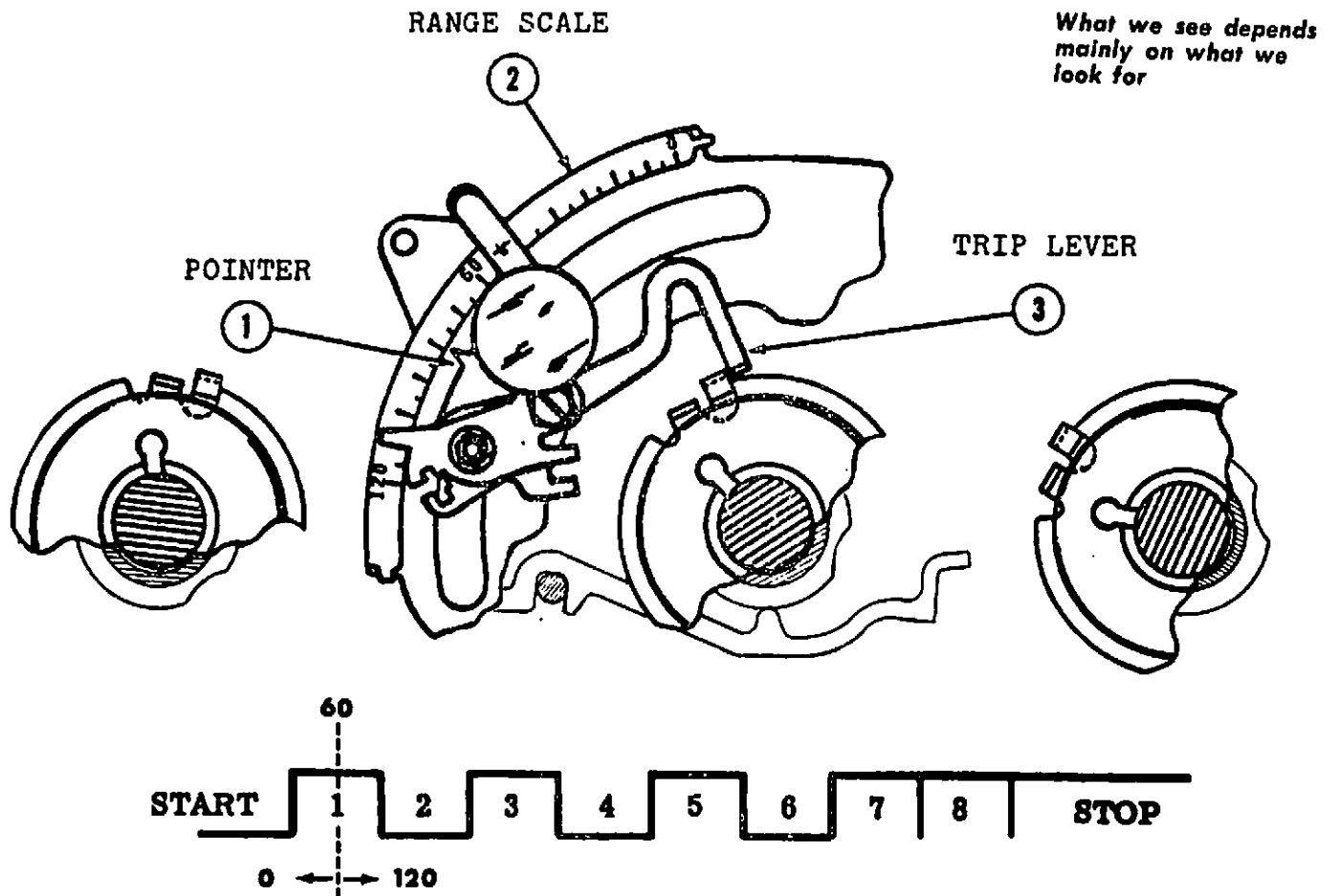

Moving the POINTER (1) along RANGE SCALE (2) alters the position of the CLUTCH TRIP LEVER (3). This action determines where the selector begins and ends its cycle. It also alters the various cams in respect to their associated levers. This determines the time in which a code element is sampled.

## CODE BAR AND FUNCTION CLUTCHES

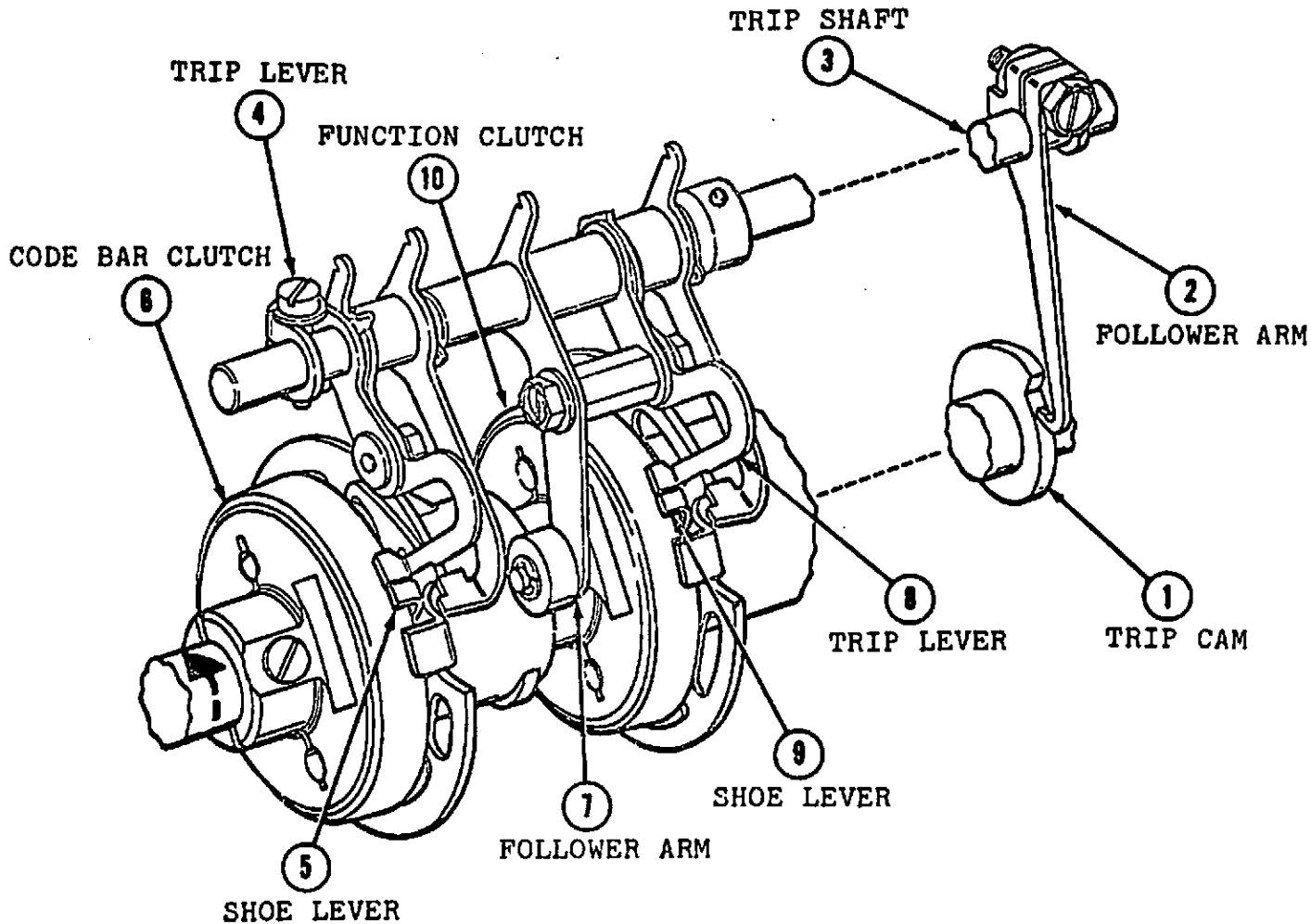

### Code Bar Clutch:

CODE BAR CLUTCH TRIP CAM (1) (selector clutch) operates TRIP FOLLOWER ARM (2) up, rotating TRIP SHAFT (3).

Attached CODE BAR CLUTCH TRIP LEVER (4) moves up releasing SHOE LEVER (5) engaging CODE BAR CLUTCH (6).

### Function Clutch:

During code bar clutch cycle, FUNCTION TRIP FOLLOWER ARM (7) is cammed up raising FUNCTION CLUTCH TRIP LEVER (8) up releasing SHOE LEVER (9). FUNCTION CLUTCH (10) engages.

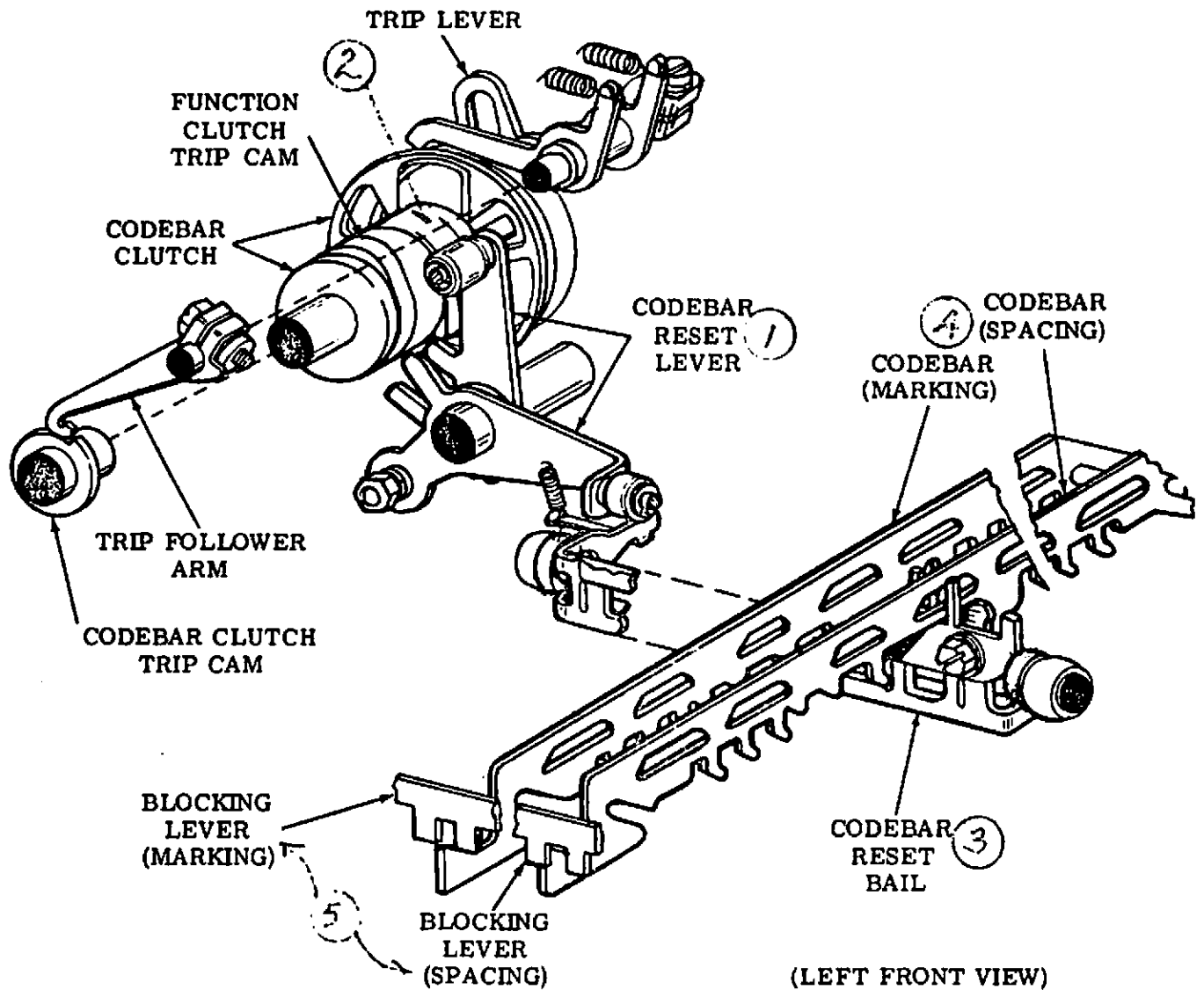

Codebar Mechanism

As clutch begins cycle, CODE BAR RESET LEVER (1) follows CAM SURFACE (2) permitting CODE BAR RESET BAIL (3) to pivot counter-clockwise.

CODE BARS (4) move up and to the left to sense BLOCKING LEVERS (5). Late in clutch cycle, CAM (2) operates CODE BAR RESET LEVER pivoting CODE BAR RESET BAIL (3) clockwise. CODE BARS (4) are reset down and to the right.

*Trouble: a valuable experience that hasn't happened yet*

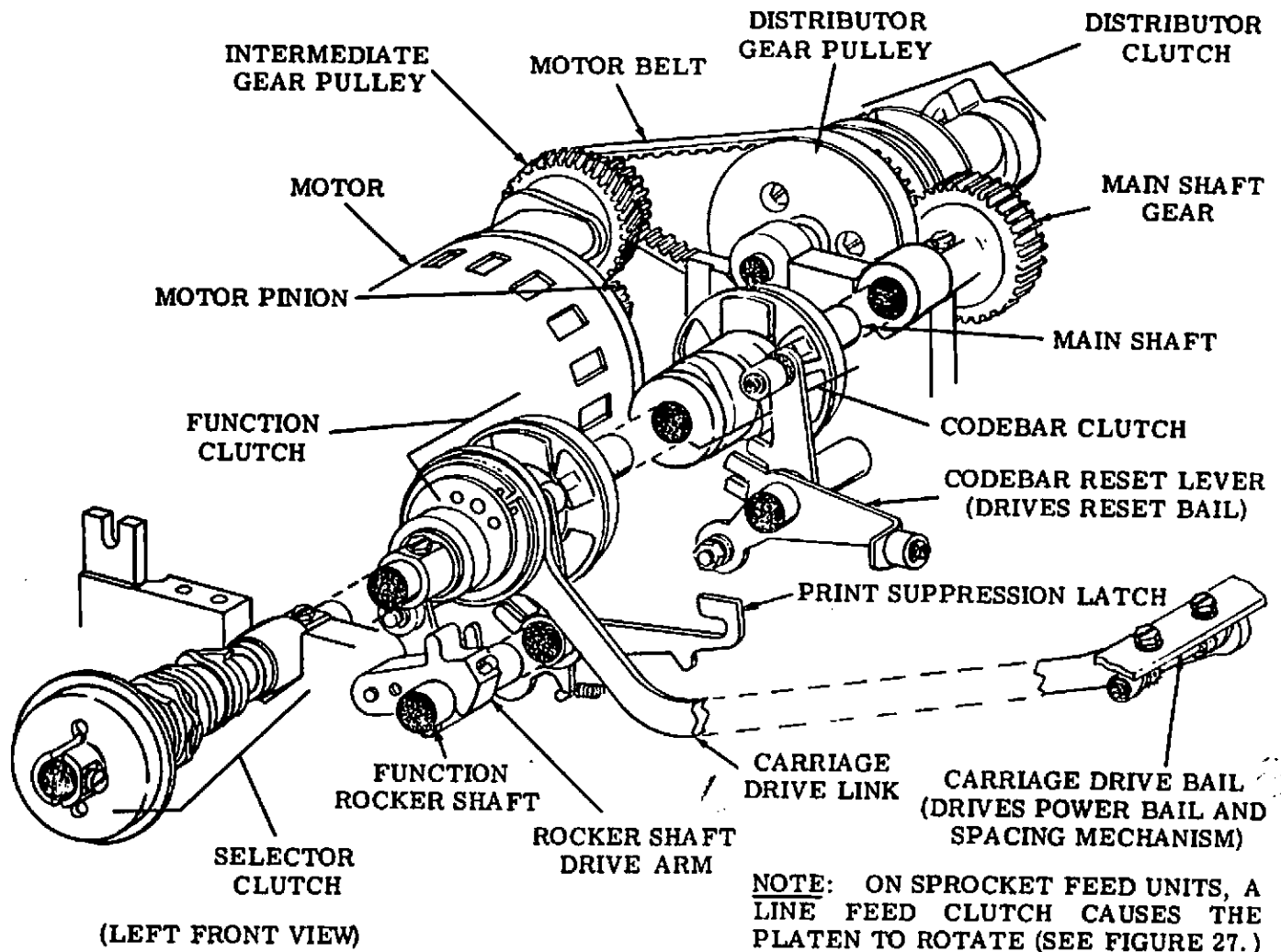

### Power Distribution

As Function Clutch begins cycle, eccentric DRIVE LINK (1) is operated, drawing the CARRIAGE DRIVE BAIL (2) to the rear. Midway through clutch cycle, the DRIVE LINK (1) returns the CARRIAGE DRIVE BAIL (2) forward.

This action directs motion into the print carriage and spacing mechanism.

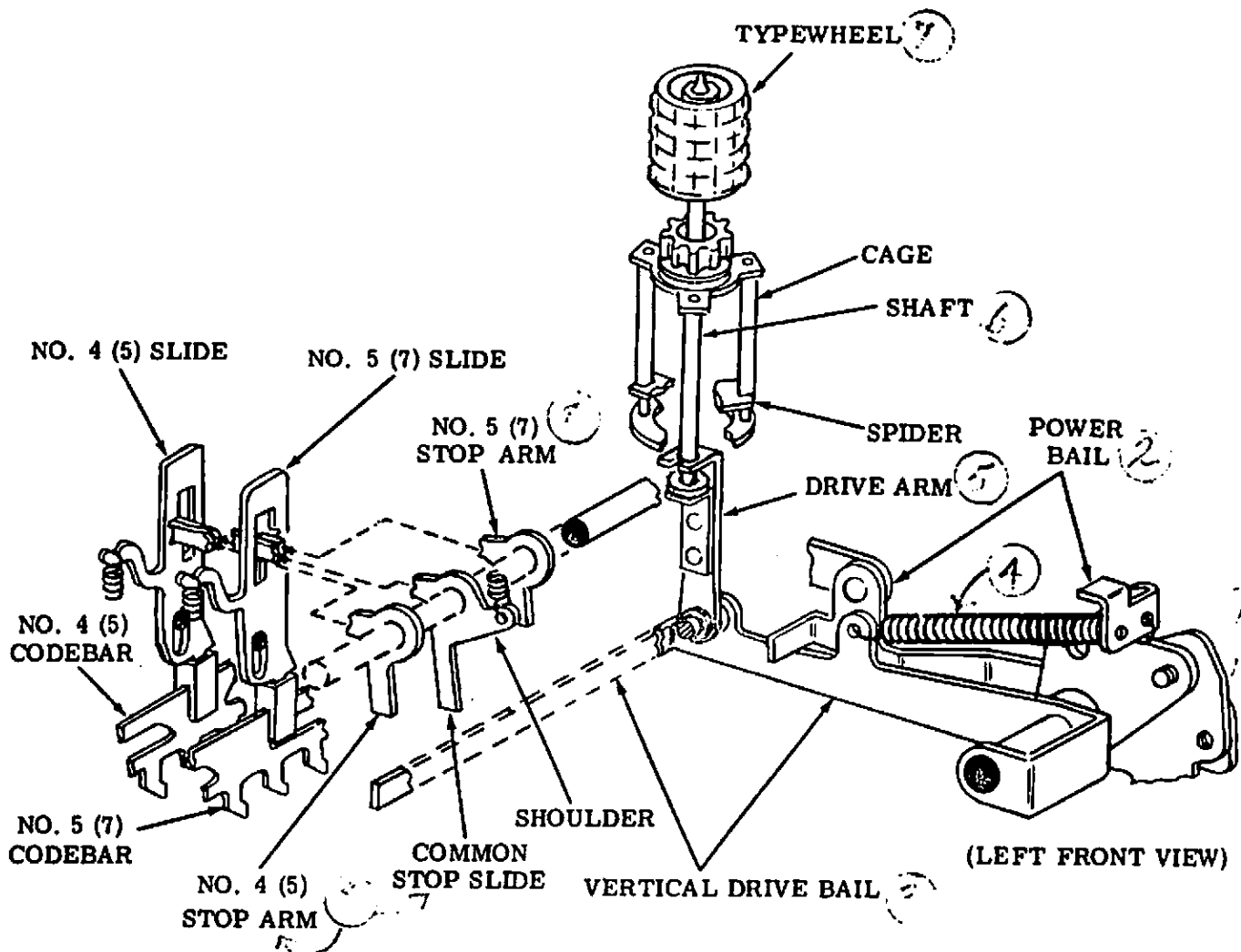

Vertical Positioning Mechanism

CARRIAGE DRIVE BAIL (1) travels to the rear, POWER BAIL (2) pivots clockwise, transferring motion to VERTICAL DRIVE BAIL (3), through a VERTICAL DRIVE SPRING (4).

DRIVE ARM (5), shaft (6), and TYPEWHEEL (7) are raised until VERTICAL DRIVE BAIL (3) encounters one of three STOP ARMS (8).

No. 5 and No. 7 SLIDES (9) follow No. 5 and No. 7 CODE BARS (10) to pivot STOP ARMS (8) in or out of VERTICAL DRIVE BAIL (3) path.

Common stop arm follows the movement of No. 5 or No. 7 slide or both.

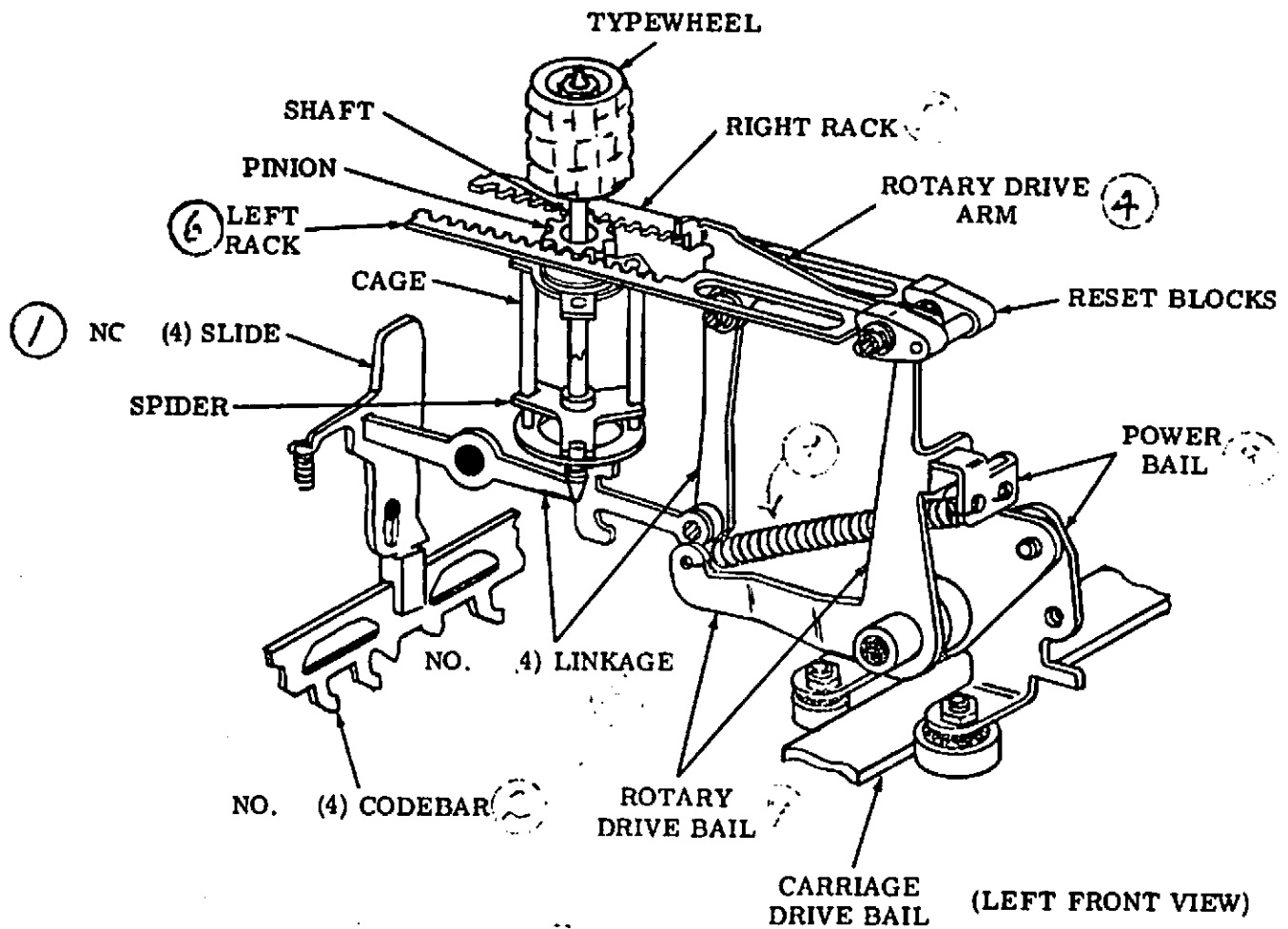

Rotary Positioning Mechanism

(No. 4) slide (1) follows (NO. 4) CODE BARD (2), operating LINKAGE (3), moving the ROTARY DRIVE ARM (4) up to engage RIGHT RACK (5) or down to engage LEFT RACK (6).

Selected rack is pulled forward as DRIVE BAIL (7) rotates POWER BAIL (8) clockwise, transferring motion through ROTARY DRIVE SPRING (9) into ROTARY DRIVE BAIL (10).

Right rack forward, right typewheel rotates clockwise.

Left rack forward, right typewheel rotates counterclockwise.

*It takes a lot of endurance to make up for bad judgment*

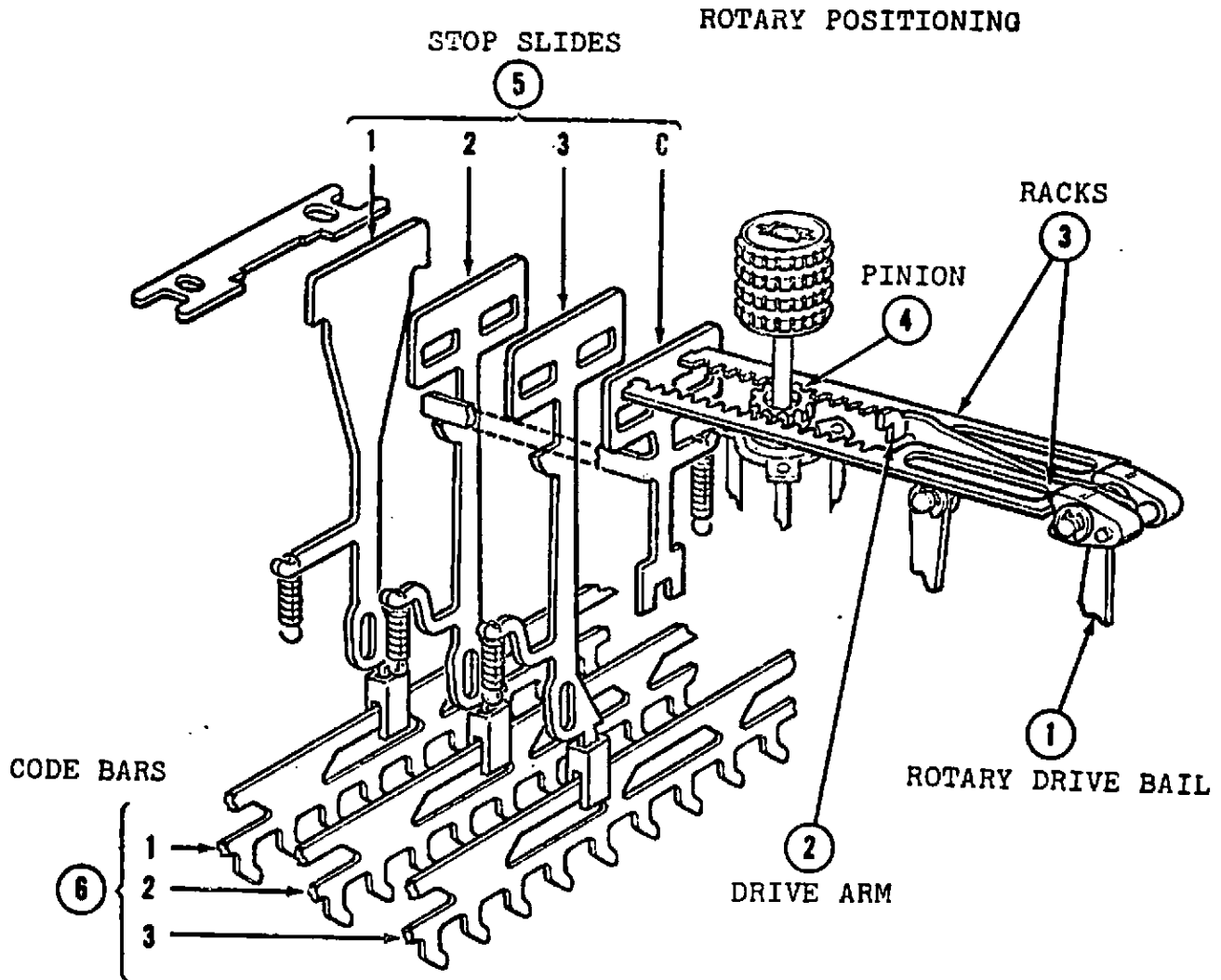

ROTARY DRIVE BAIL (1) rocks clockwise, operating DRIVE ARM (2) and selected RACK (3) forward right. The opposite RACK (3) is operated to the rear by PINION (4) until it is blocked by one of four STOP SLIDES (5).

Movement of three CODE BARS (6) will control the positioning of four SLIDES (5).

Common stop slide follows No. 2 or No. 3 stop slide or both. Slides positioned upward will present an opening for the rack to pass through.

Slides remaining down, will block rack movement.

Typewheel rotation will correspond to the amount of rack movement.

## GUIDE PLATES

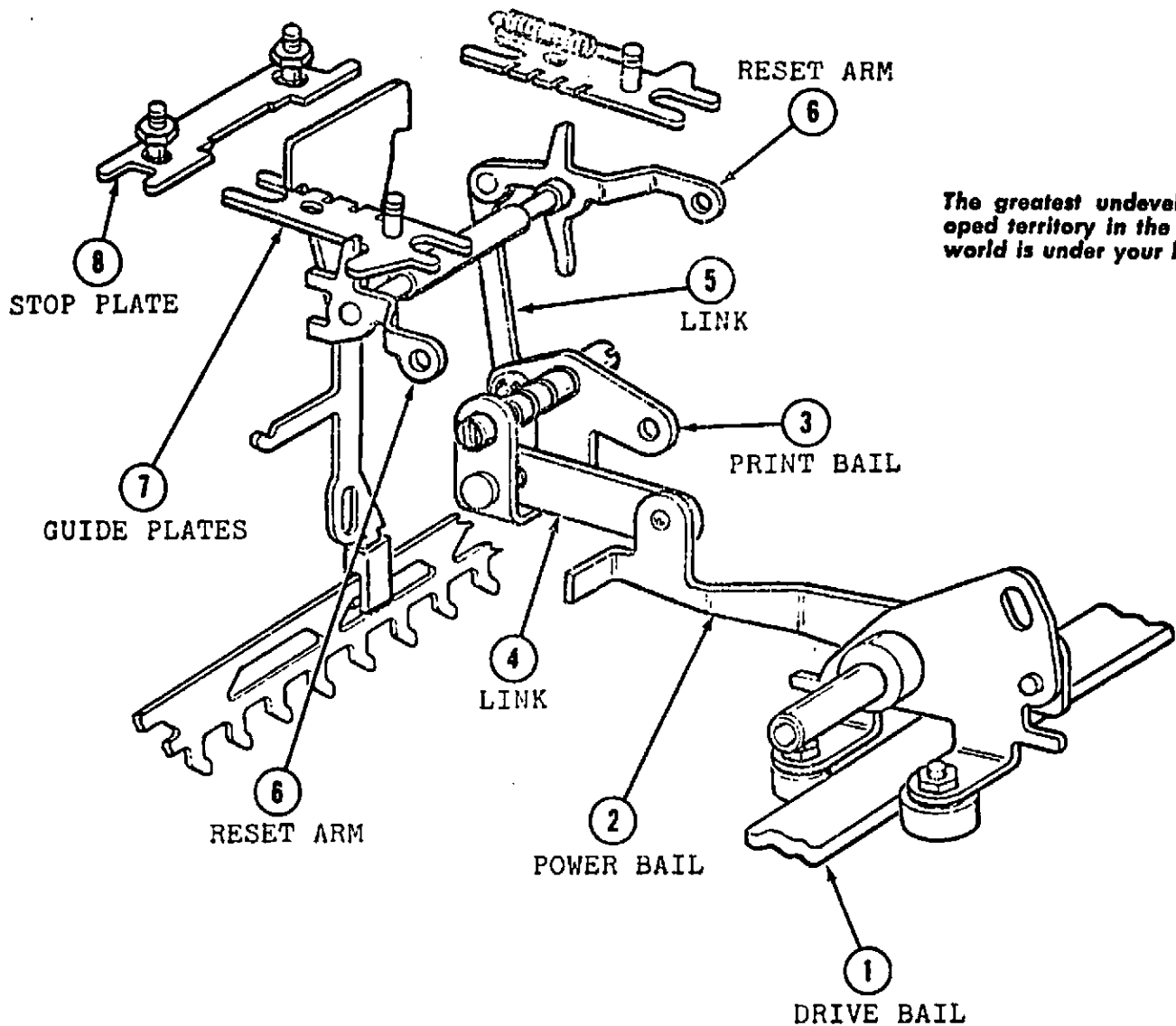

*The greatest undeveloped territory in the world is under your hat*

As cycle begins, DRIVE BAIL (1) moves up to the rear, POWER BAIL (2) pivots up delivering counterclockwise motion into PRINT BAIL (3) through LINK (4). Motion of PRINT BAIL (3) draws LINK (5) down, rotating two RESET ARMS (6) counterclockwise. Two GUIDE PLATES (7) which house stop slides, move toward STOP PLATE (8) under spring tension. Late in cycle, as DRIVE BAIL (1) moves forward, RESET ARMS (6) return GUIDE PLATES (7) and slides forward.

## ODD AND EVEN ROW

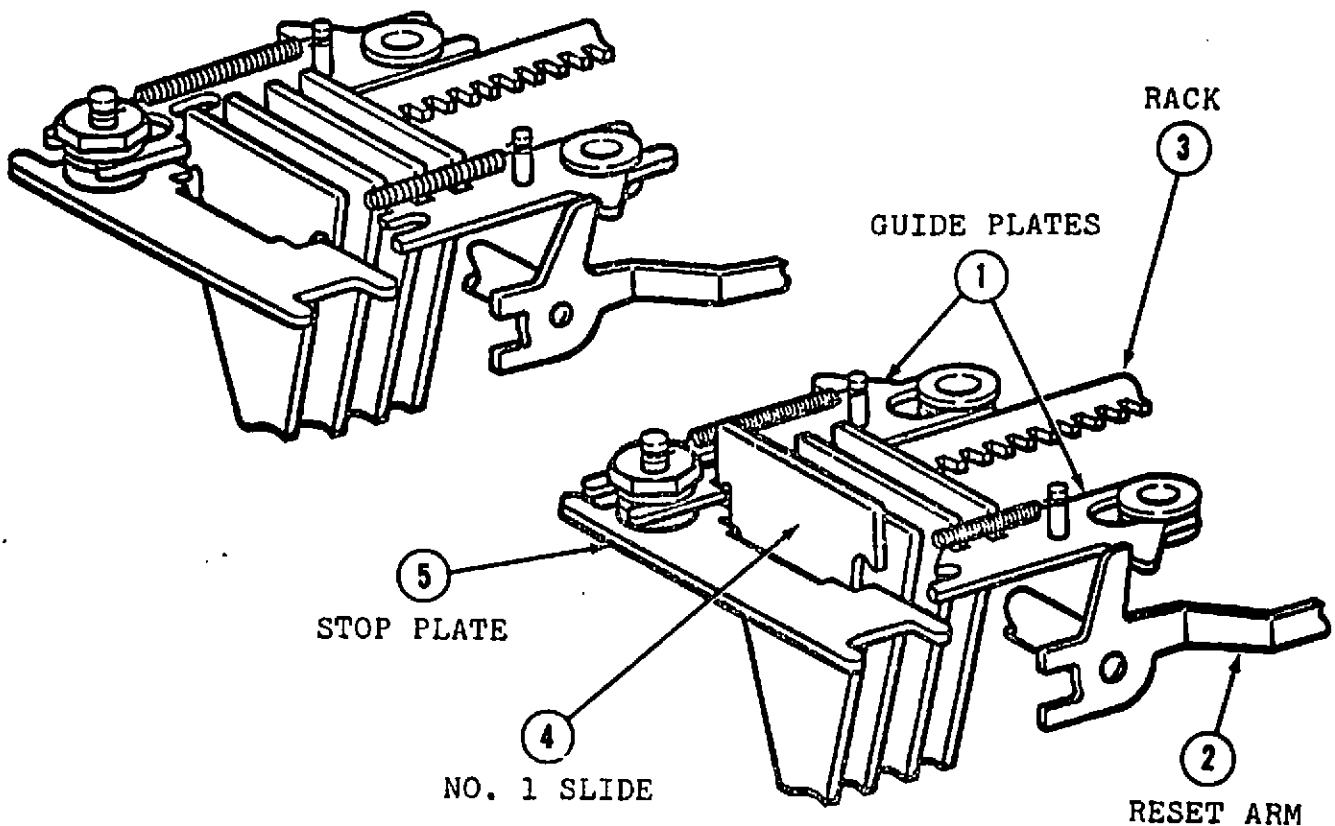

GUIDE PLATES (1) housing slides, are released by RESET ARMS (2) and begin moving to the rear under spring tension. A RACK (3) is operated to the rear, pushing the assembly rearward until No. 1 Slide (4) (shift slide) engages the STOP PLATE (5) on one of two stop surfaces.

The position of No. 1 slide (up or down) will determine which row (odd or even) is selected on the typewheel.

No. 1 slide down, the front stop surface of stop plate is engaged, limiting the rack output to select the odd rows.

No. 1 slide up, the rear stop surface of stop plate is engaged increasing the rack output to select the even rows.

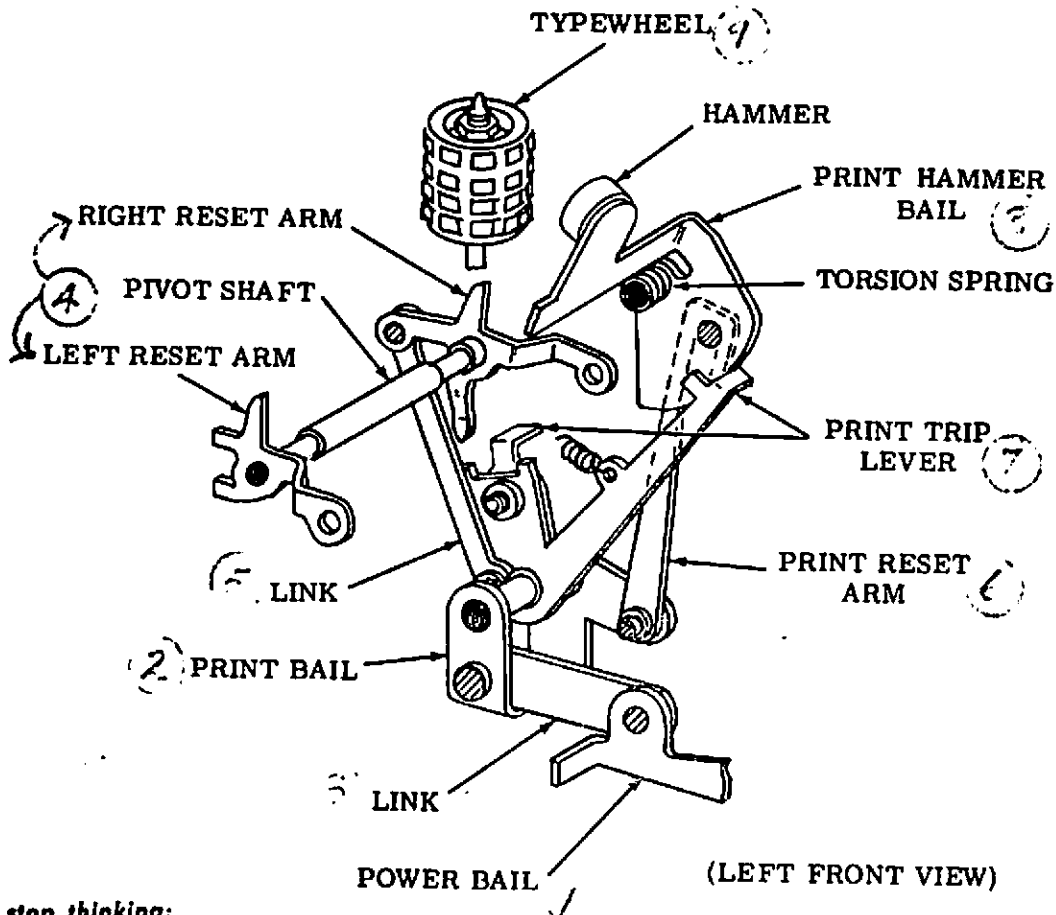

*Don't stop thinking;  
just stop and think*

Figure 20 - Printing Mechanism

POWER BAIL (1) moves up transferring clockwise motion into PRINT BAIL (2), through LINK (3). Motion of PRINT BAIL (2) moves RESET ARM (4) up, and draws LINK (5) down, rotating RESET ARM (6) clockwise.

RESET ARM (6) engages and pivots the TRIP LEVER (7) counterclockwise to release HAMMER BAIL (8). HAMMER BAIL (8) snaps rearward driving TYPEWHEEL (9) against the ribbon and paper.

Motion in mechanism is reversed as POWER BAIL (1) returns down.

RESET ARM (4) will rotate HAMMER BAIL (8) counterclockwise until latched by TRIP LEVER (7).

PRINTING AREA



1st	▽	&	%	\$	#	^	!	A <sup>M</sup> SP	(	)	*	+	,	-	.	/
2nd	G	F	E	D	C	B	A	@	H	I	J	K	L	M	N	O
3rd	7	6	5	4	3	2	1	0	8	9	:	:	<	=	>	?
4th	W	V	U	T	S	R	Q	P	X	Y	Z	[	\	]	↑	←
	8	7	6	5	4	3	2	1	1	2	3	4	5	6	7	8

CLOCKWISE

COUNTERCLOCKWISE

VERTICAL ROWS

(SHOWN IN STOP POSITION)

\* Typical Typewheel Character Arrangement (As Printed)

574-122-100 MOD. 32 & 33 TYPING UNIT

CODE BAR AND SLIDE ARRANGEMENT

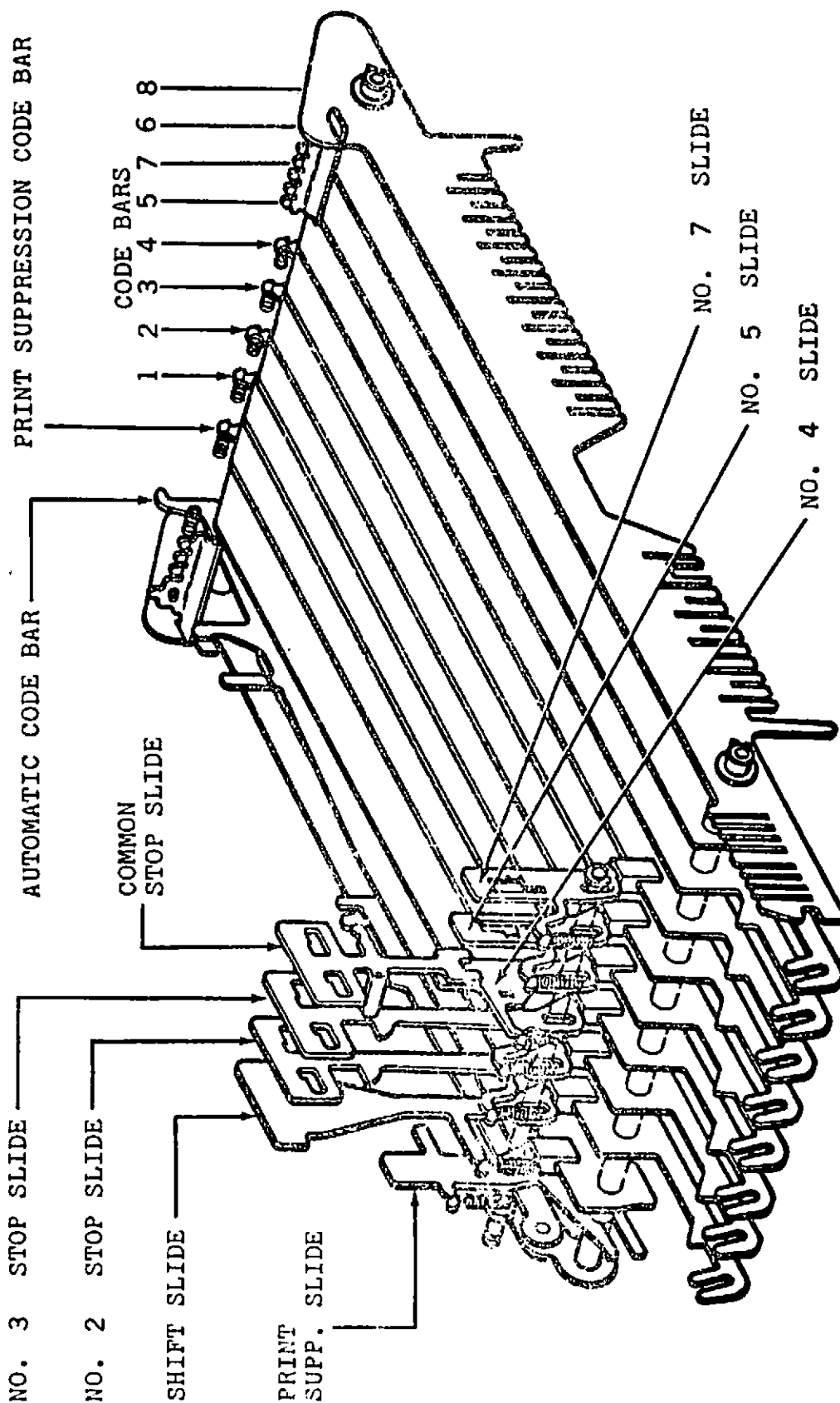

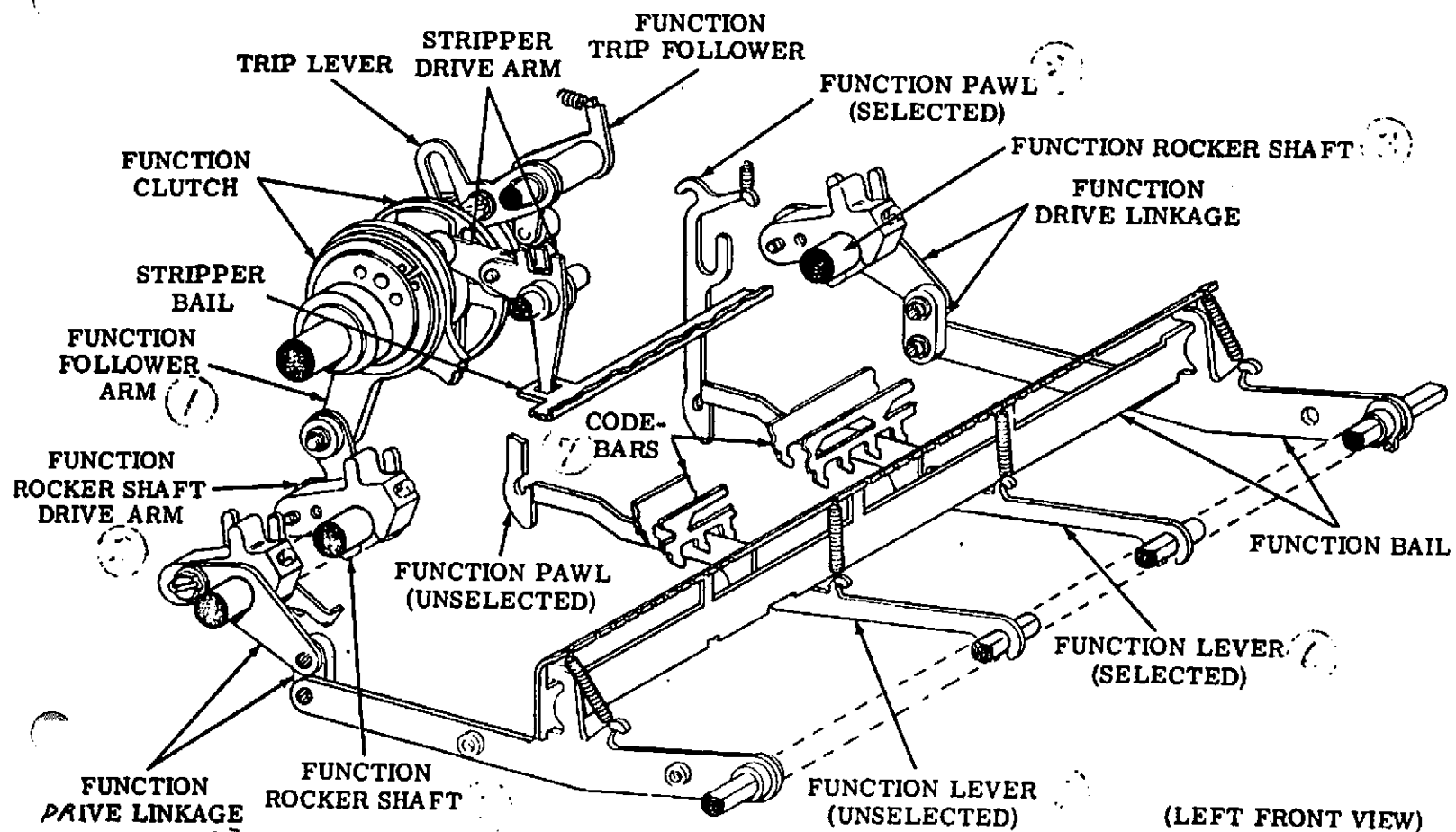

As clutch cycle begins, FUNCTION FOLLOWER ARM (1) moves down operating the DRIVE ARM (2), rotating FUNCTION ROCKER SHAFT (3) counterclockwise.

FUNCTION DRIVE LINKAGE (4) pivots, raising the FUNCTION BAIL (5).

FUNCTION LEVERS (6) move up to sense the coded projections of CODE BARS (7). Various code bar arrangements permit a function lever to engage a FUNCTION PAWL (8) (selected). Unselected levers are blocked by code bar projections.

Midway through clutch cycle, ROCKER SHAFT (3) rotates clockwise returning FUNCTION BAIL (5) and FUNCTION LEVERS (6) down. A selected PAWL (8) will be operated down also.

## FUNCTION STRIPPER BAIL

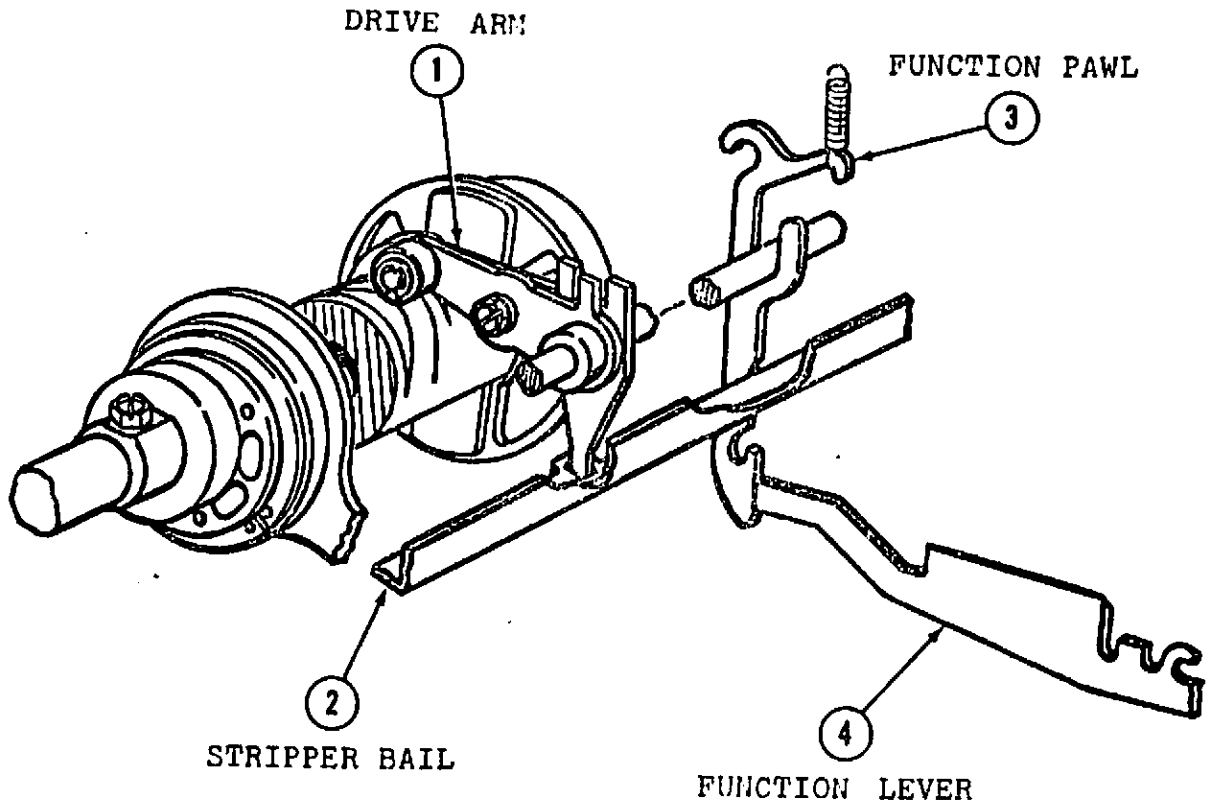

As cuntcion clutch begins cycle, STRIPPER DRIVE ARM (1) operates counterclockwise. STRIPPER BAIL (2) moves forward, allowing function action to occur.

Late in clutch cycle, STRIPPER DRIVE ARM (1) operates clockwise, STRIPPER BAIL (2) returns to the rear, disengaging selected FUNCTION PAWL (3) from FUNCTION LEVER (4).

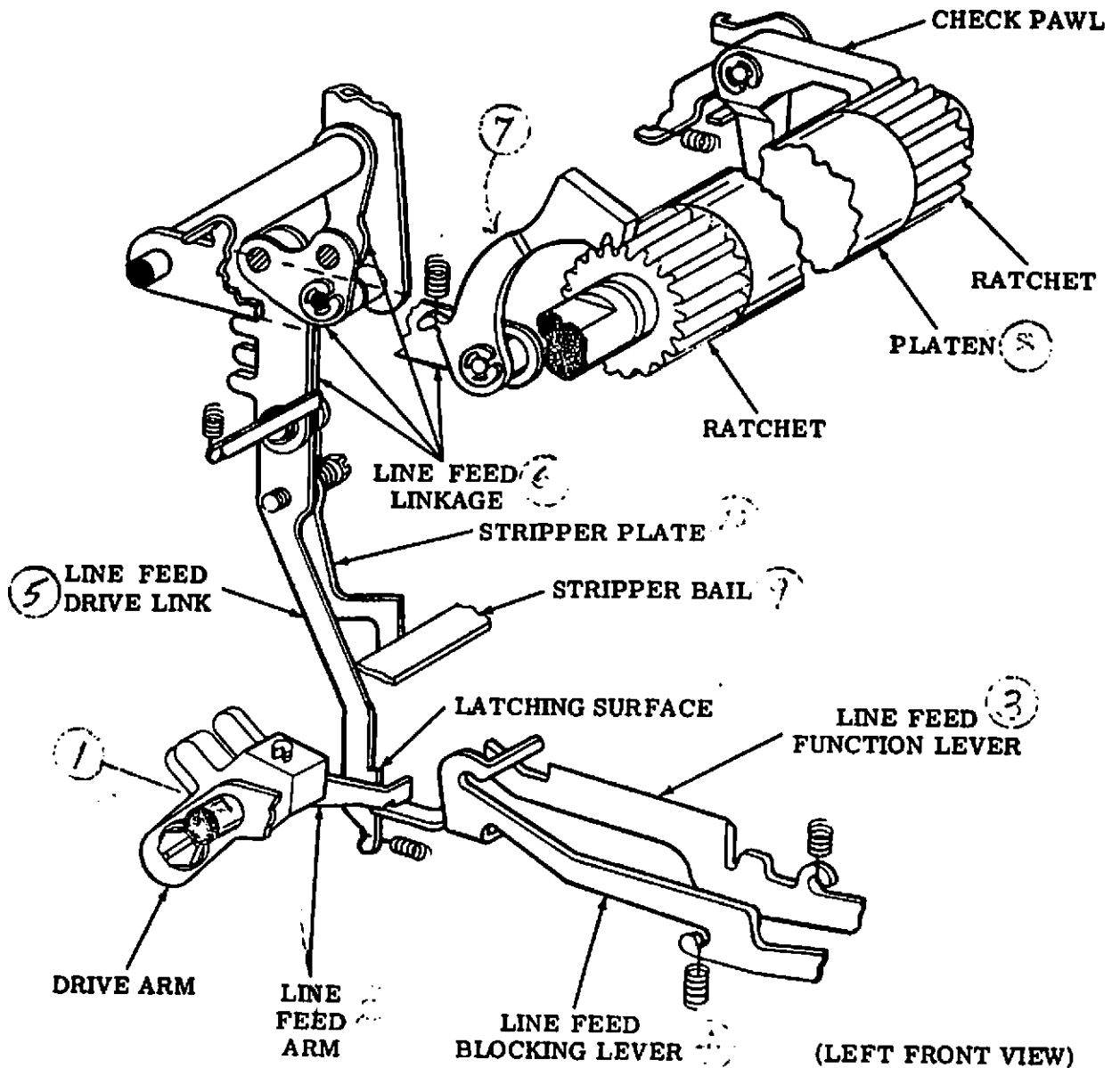

Paper Feed Mechanism (Friction Feed).

FUNCTION ROCKER SHAFT (1) rotates counterclockwise raising LINE FEED ARM (2). As ROCKER SHAFT (1) rotates, LINE FEED FUNCTION LEVER (3) is selected, and lifts the LINE FEED BLOCKING LEVER (4). ROCKER SHAFT (1) rotates clockwise, operating LINE FEED ARM (2) down, driving latched BLOCKING LEVER (4) down. BLOCKING LEVER (4) pulls DRIVE LINK (5) down, operating LINKAGE (6) which pulls PAWL (7) down, rotating PLATEN (8) counterclockwise. Late in cycle, STRIPPER BAIL (9) moves STRIPPER PLATE (10) rearward, disengaging DRIVE LINK (5) from BLOCKING LEVER (4).

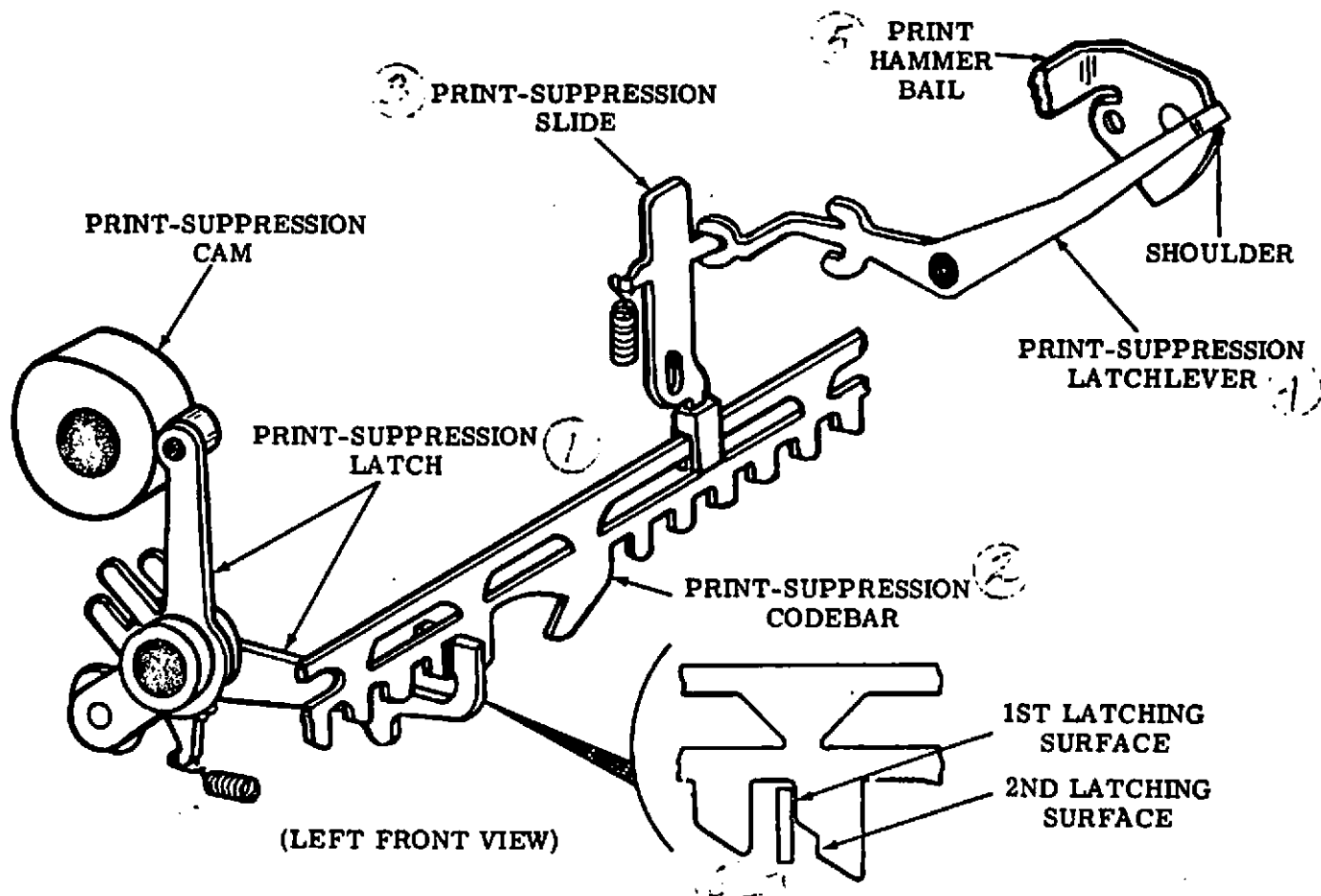

- Print Suppression Mechanism

**Printing Cycle:**

Function Clutch cams PRINT SUPPRESSION LATCH (1) clockwise, releasing the P. S. CODE BAR (2). P. S. CODE BAR (2) movement operates the P. S. SLIDE (3), pivoting the P. S. LATCH LEVER (4) clockwise to unlatch the PRINT HAMMER BAIL (5).

**Non-Printing Cycle:**

Each time the printer is conditioned for a function operation, printing will be suppressed. As Function Clutch cycles and pivots the P. S. Latch (1) to release the P. S. CODE BAR (2), a selected FUNCTION LEVER (6) moves upward into the corresponding tines of the P. S. CODE BAR (2), providing a second blocking condition. The P. S. CODE BAR (2), SLIDE (3), and LATCH LEVER (4) remain unoperated. PRINT HAMMER BAIL (5) remains latched.

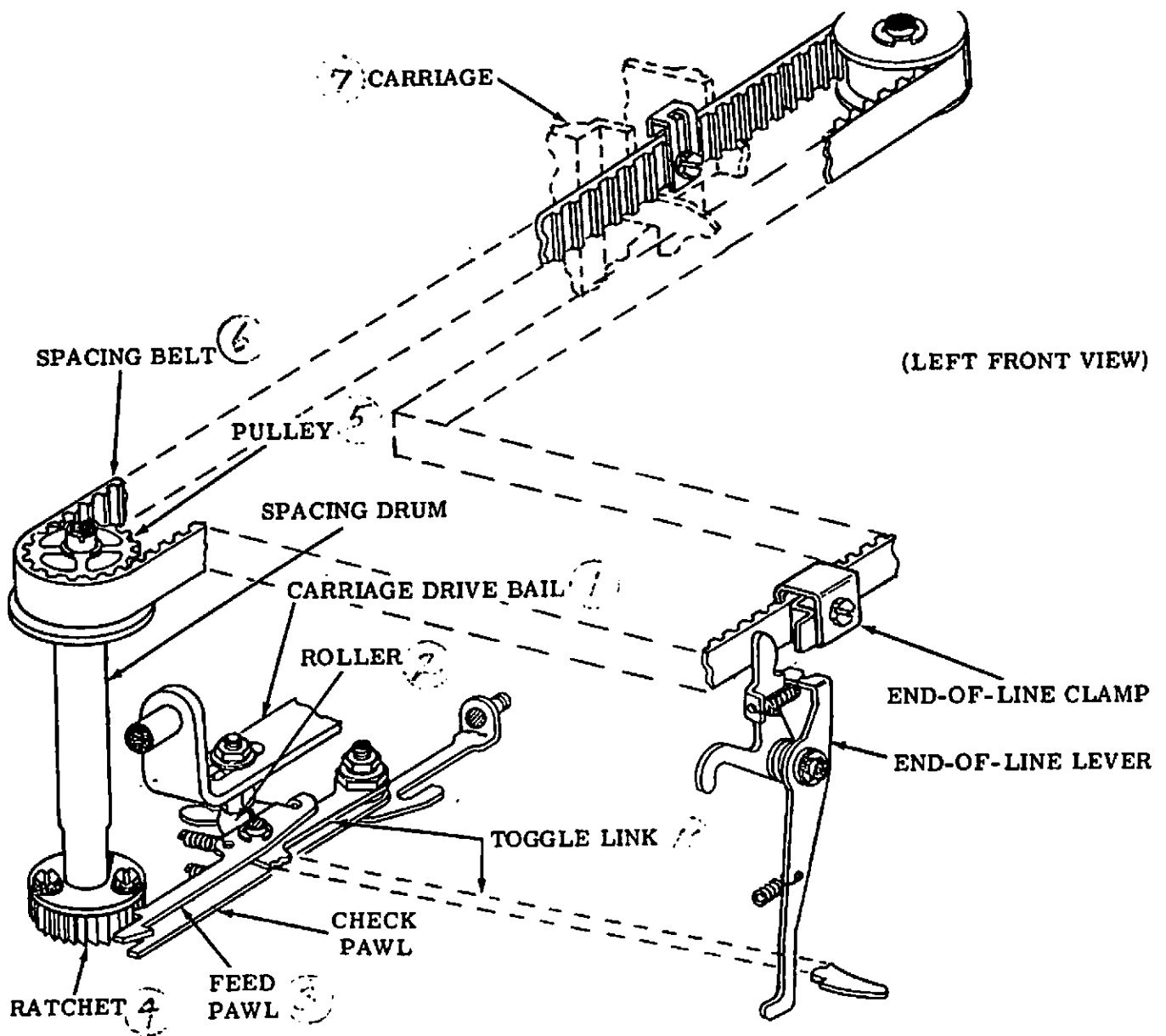

- Spacing Mechanism

CARRIAGE DRIVE BAIL (1) and attached ROLLER (2) move to the rear, allowing FEED PAWL (3) to select a new tooth on RATCHET (4).

CARRIAGE DRIVE BAIL (1) and ROLLER (2) move forward, driving FEED PAWL (3) to advance RATCHET (4), PULLEY (5), BELT (6), and CARRIAGE (7) one unit.

As carriage approaches end of platen, END-OF-LINE CLAMP (8) engages END-OF-LINE LEVER (9), which blocks TOGGLE LINK (10), preventing additional FEED PAWL (3) action.

Half empty to the pessimist is half full to the optimist

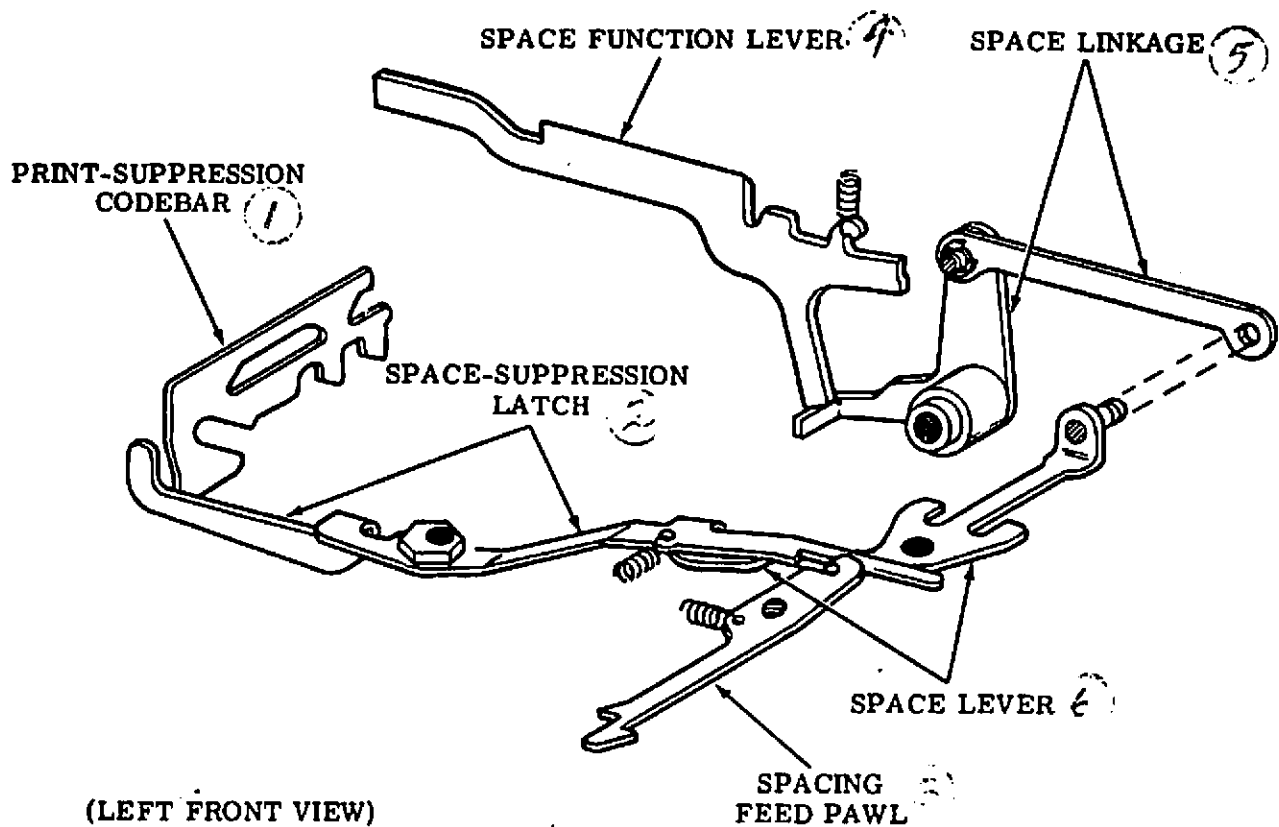

16 -- Space Function and Space-Suppression Mechanism

**Printing Cycle:**

Print suppression CODE BAR (1) moves left, pivoting SPACE SUPPRESSION LATCH (2). The FEED PAWL (3) will operate and space the carriage one unit.

**Non-printing Cycle:**

PRINT SUPPRESSION CODE BAR (1) is held by a function lever. SPACE SUPPRESSION LATCH (2) blocks FEED PAWL (3) action. Spacing action is suppressed.

On space code combination, the space FUNCTION LEVER (4) is selected, holding PRINT SUPPRESSION CODE BAR (1) to the right. As space FUNCTION LEVER (4) moves up, SPACE LINKAGE (5) operates forward, pivoting the space lever (6) to move SPACE SUPPRESSION LATCH (2) away from the FEED PAWL (3). Spacing will occur.

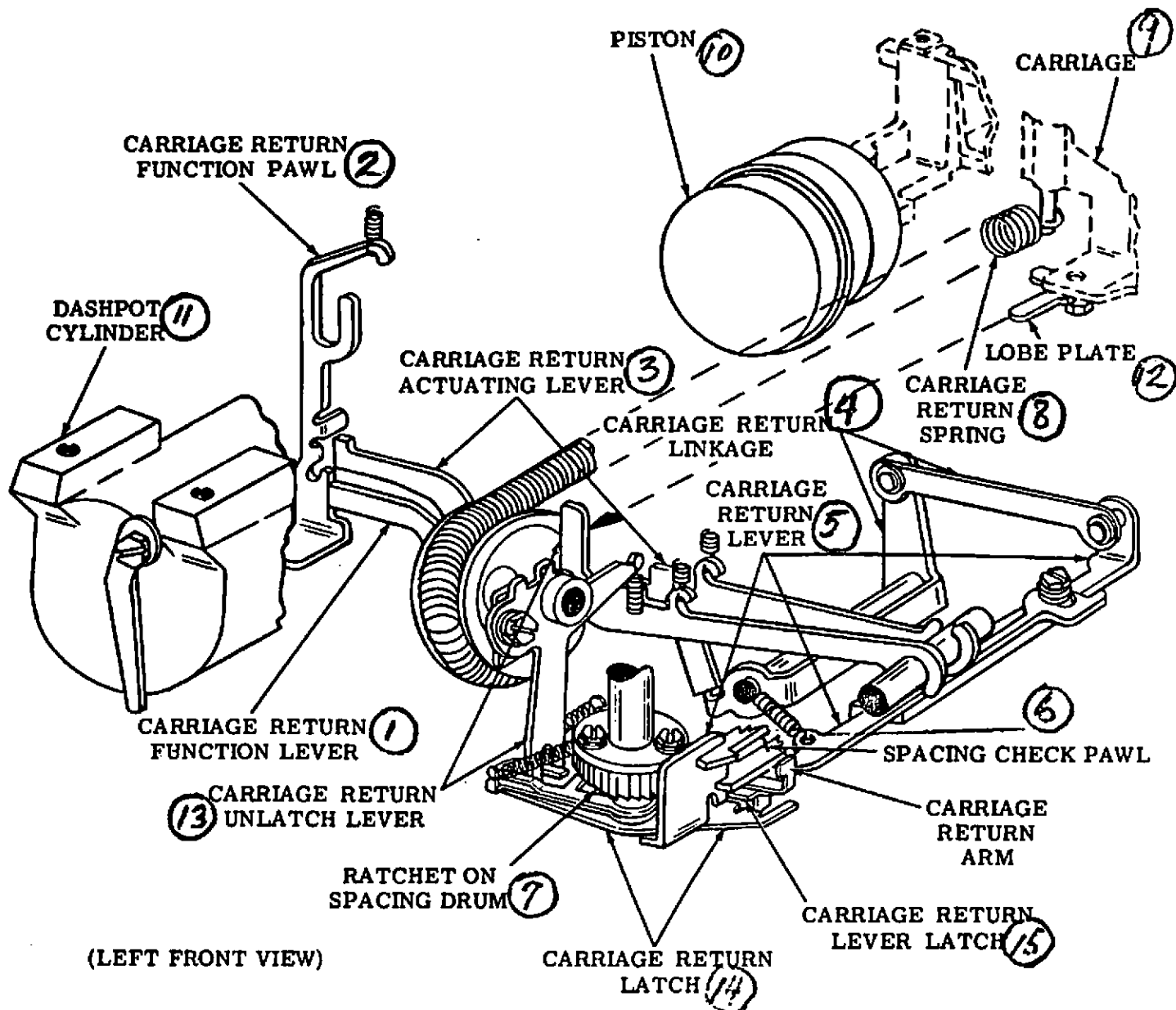

— Carriage Return Mechanism

CARRIAGE RETURN FUNCTION LEVER (1), is selected, and engages FUNCTION PAWL (2). FUNCTION PAWL (2) is operated down, driving ACTUATING LEVER (3) down.

CARRIAGE RETURN LINKAGE (4) is operated to the rear, pivoting CARRIAGE RETURN LEVER (5) lifting the FEED AND CHECK PAWL (6) from the SPACING RATCHET (7).

As SPRING (8) returns CARRIAGE (9) to the left, PISTON (10) enters DASHPOT (11). LOBE PLATE (12) strikes UNLATCH LEVER (13) which operates the CARRIAGE RETURN LATCH (14), freeing the CARRIAGE RETURN LEVER (15).

## UNLATCHING

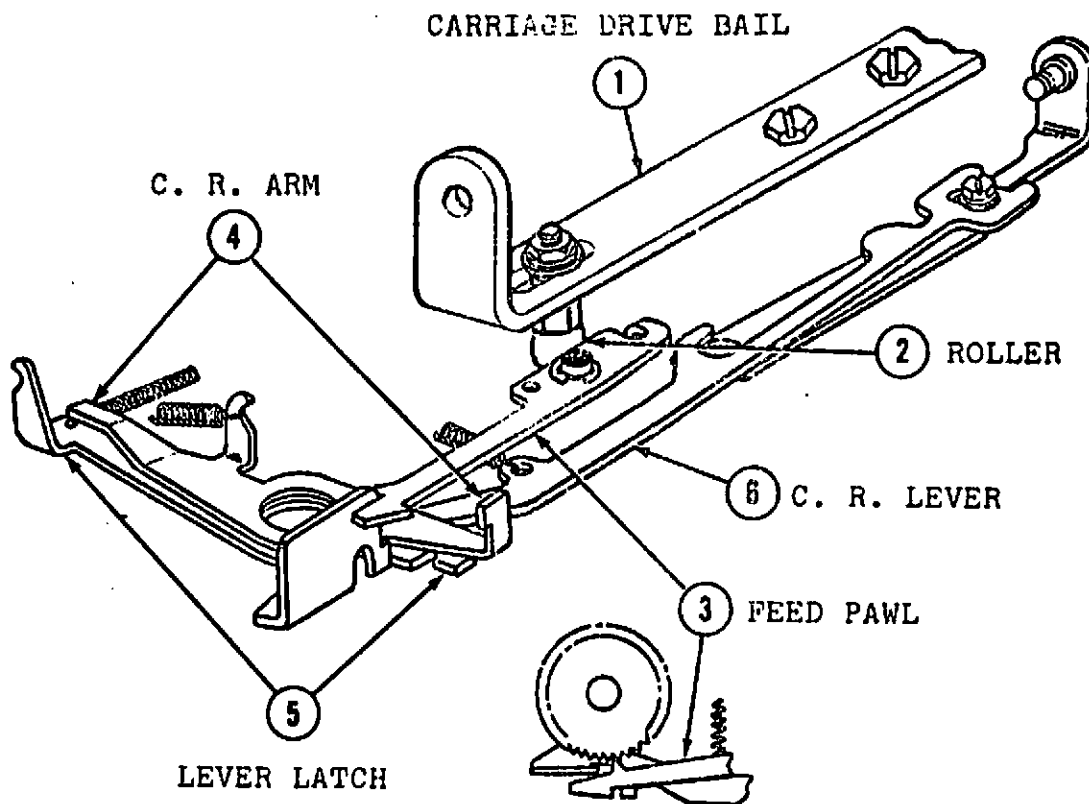

*A driver is a former pedestrian out for revenge*

As printer begins another printing cycle, CARRIAGE DRIVE BAIL (1) with attached ROLLER (2), move to the rear.

As FEED PAWL (3) follows ROLLER (2), it engages CARRIAGE RETURN ARM (4), which operates the LEVER LATCH (5), freeing the CARRIAGE RETURN LEVER (6). Feed Pawl and check pawl return to spacing ratchet.

## RIBBON MECHANISM

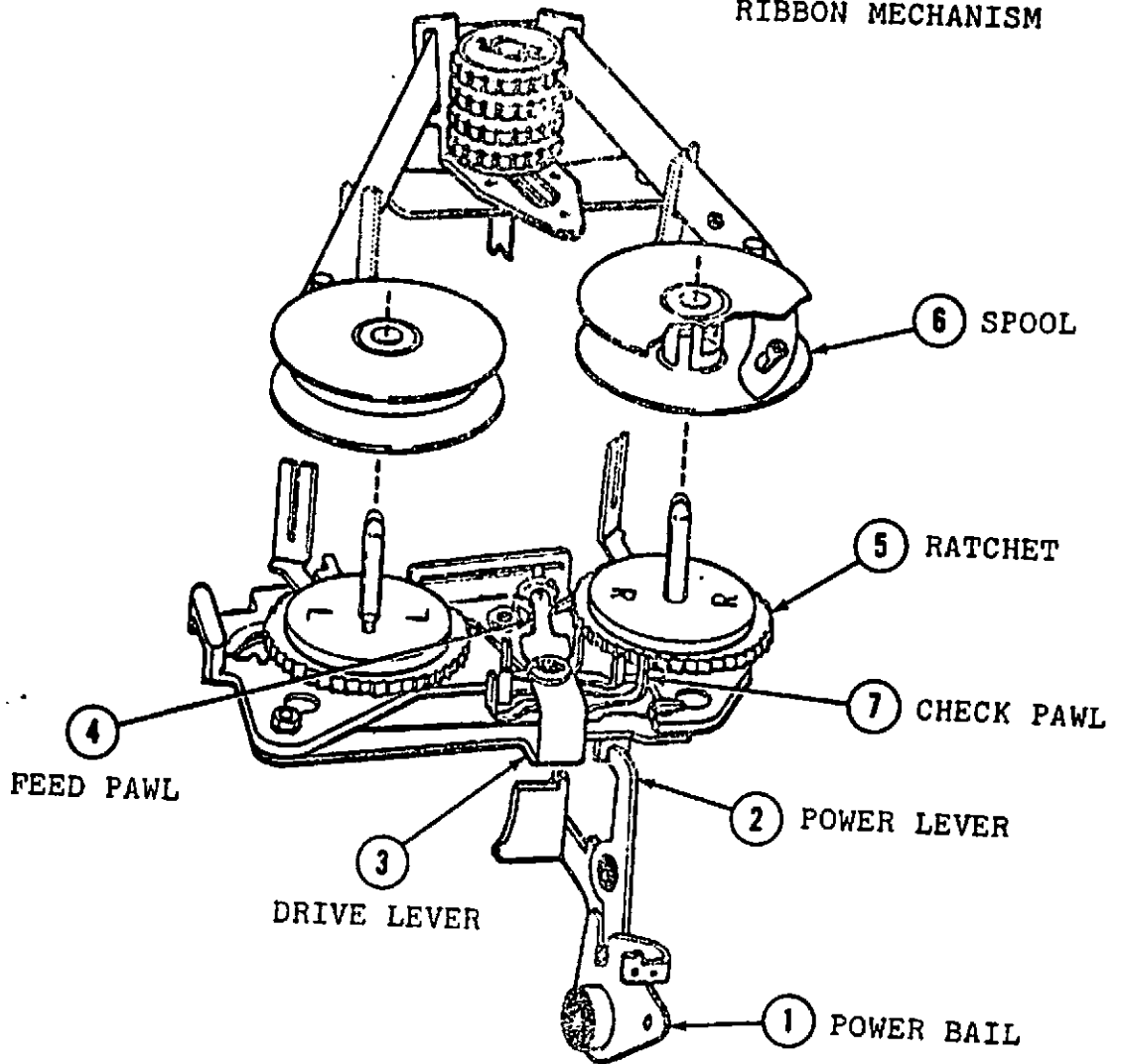

POWER BAIL (1) rocks forward, pivoting POWER LEVER (2) to the rear. DRIVE LEVER (3) and attached FEED PAWL (4) move to the rear, advancing RATCHET (5) and SPOOL (6) one unit.

CHECK PAWL (7) drops into succeeding tooth detenting RATCHET (5), as POWER BAIL (1) rocks back, allowing FEED PAWL (4) to select another ratchet tooth.

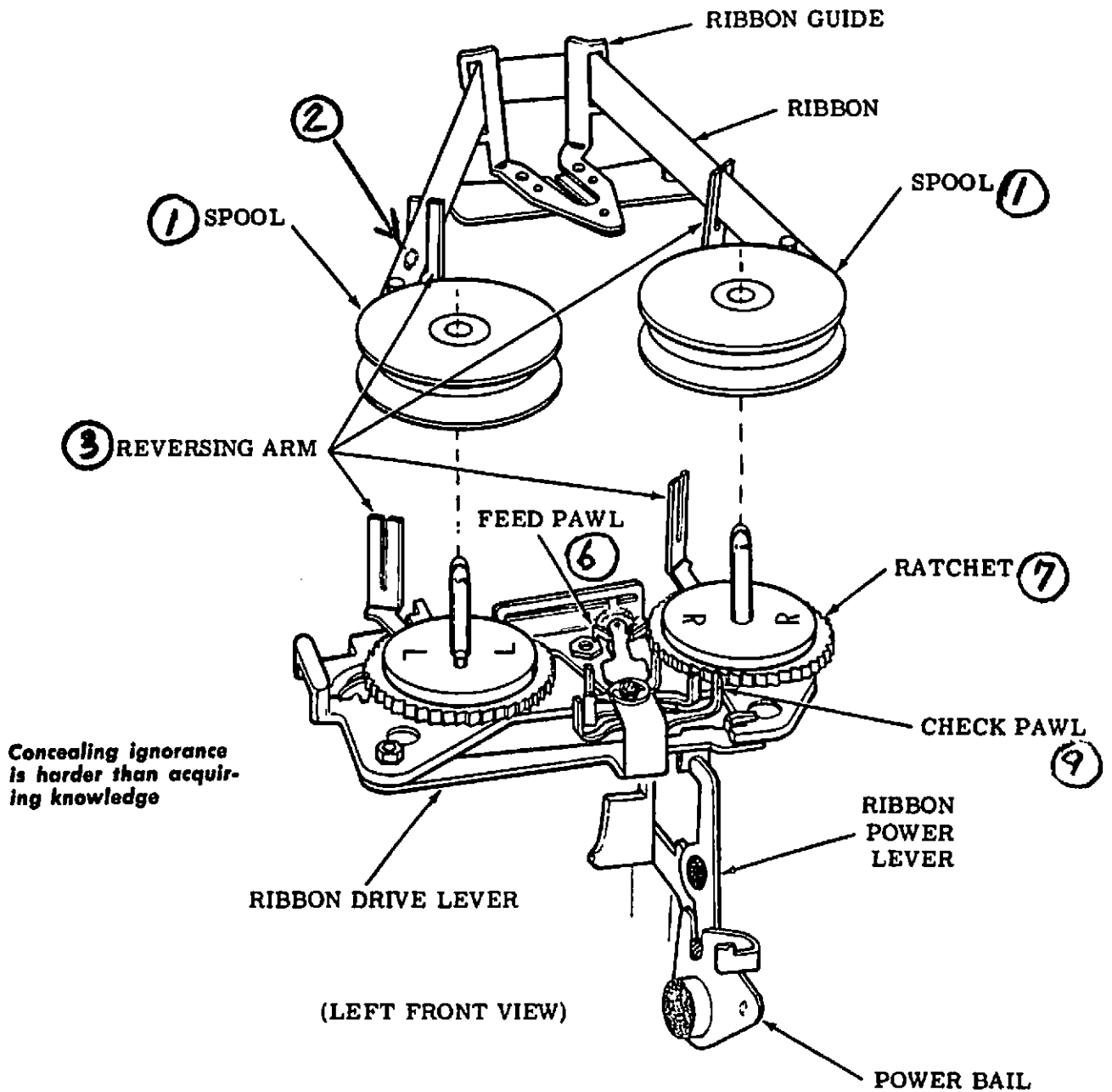

- Ribbon Mechanism

When a SPOOL (1) is nearly depleted, and EYELET (2) engages a REVERSING ARM (3) with EXTENSION (4), shifting the arm to where its EXTENSION (4) moves into the path of a FEED PAWL EXTENSION (5). As FEED PAWL (6) moves forward on next cycle, its EXTENSION (5) strikes the REVERSING ARM EXTENSION (4), and pivots toward the opposite RATCHET (7). As FEED PAWL (6) pivots, it strikes an EXTENSION (8) of the CHECK PAWL (9) moving the check pawl to the opposite ratchet.

FUNCTION LEVER ARRANGEMENT

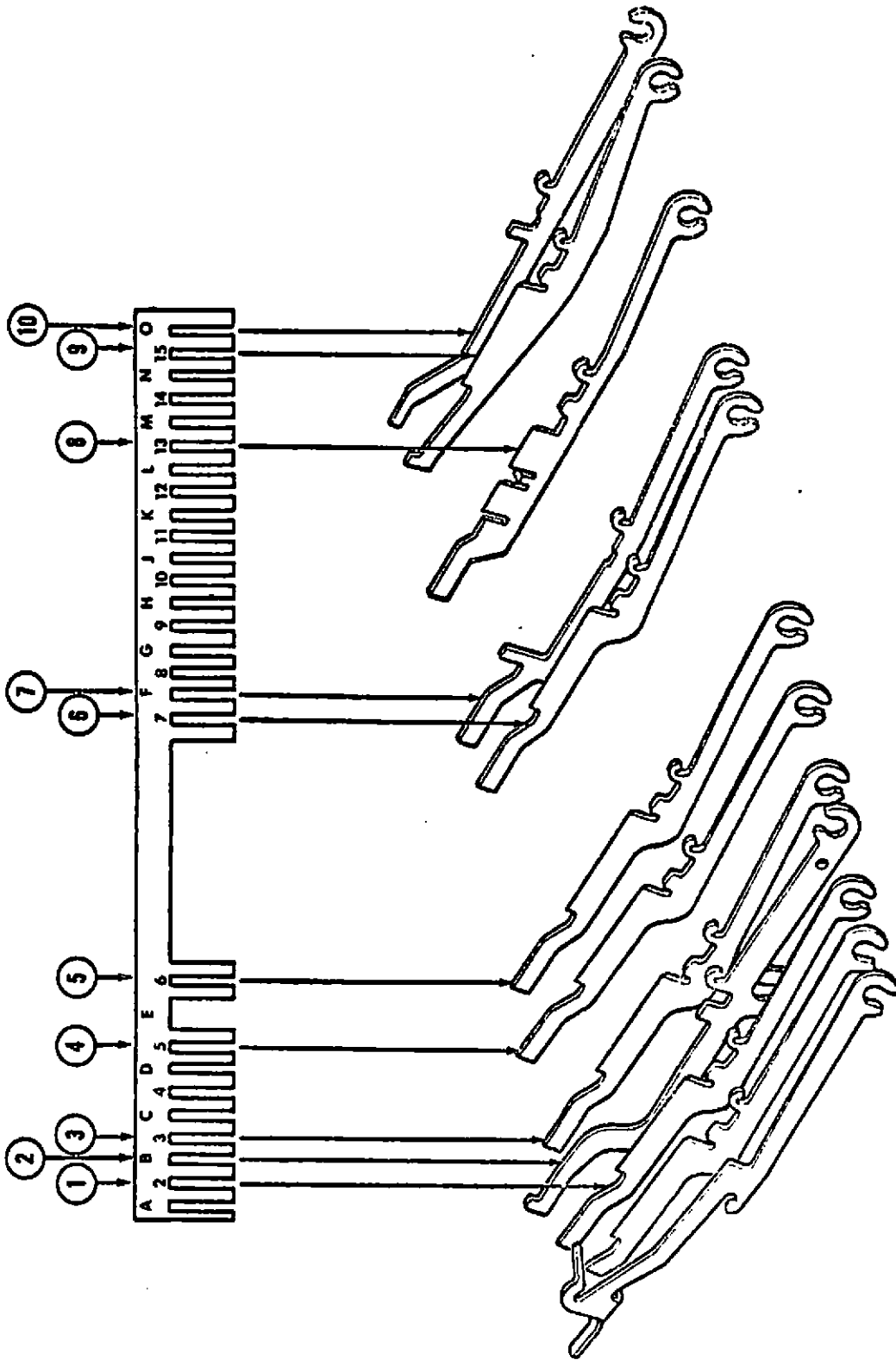

- ⑤ PRINT SUPP. ON CONTROL FUNCTIONS
- ⑥ SIGNAL BELL
- ⑦ MARGIN BELL
- ⑧ E.O.T.
- ⑨ ANS. BACK
- ⑩ A.B. BLOCKING LATCH LEVER

- ① LINE FEED
- ② L.F. BLOCKING LEVER
- ③ CARRIAGE RETURN
- ④ C.R. DRIVE LEVER
- ⑤ SPACE
- ⑥ PRINT SUPP. ON ESC. & RUB OUT

*None but a fool is  
always right*

## ANSWER-BACK MECHANISM

An answer-back mechanism, , automatically transmits a predetermined sequence of characters for identification purposes. The basic mechanism may be actuated in two ways:

- (a) Remotely, by the reception of a predetermined call character.
- (b) Locally by the depression of the HERE-IS key.
- (c) In addition, as an optional feature, it may be actuated by a trip-magnet mechanism at the receipt of a signal generated by external equipment, such as a data set. The mechanism is described in the appropriate description section.

A drum is coded with characters making up the answer-back sequence. When the answer-back mechanism is actuated, it rotates the drum, which sets up the code combinations in a set of answer-back contacts. The distributor converts the positions of the contacts to start-stop signals for transmission. After the answer-back sequence has been transmitted, the answer-back mechanism returns itself to its unoperated condition. For operational considerations that will be described below, provisions are made for shunting the signal line during sensing of the first answer-back character of each cycle of operation and for preventing the answer-back mechanism from being actuated by the local generation of the answer-back call character.

Note: See the appropriate installation section for further information on answer-back drum coding.

### B. Drum

Viewing it from the rear, the drum has 11 levels from right to left, as follows:

- (a) Five numbered levels.
- (b) Feed ratchet.
- (c) Stop cam.
- (d) Character suppression.
- (e) Three more numbered levels.

HERE IS KEY

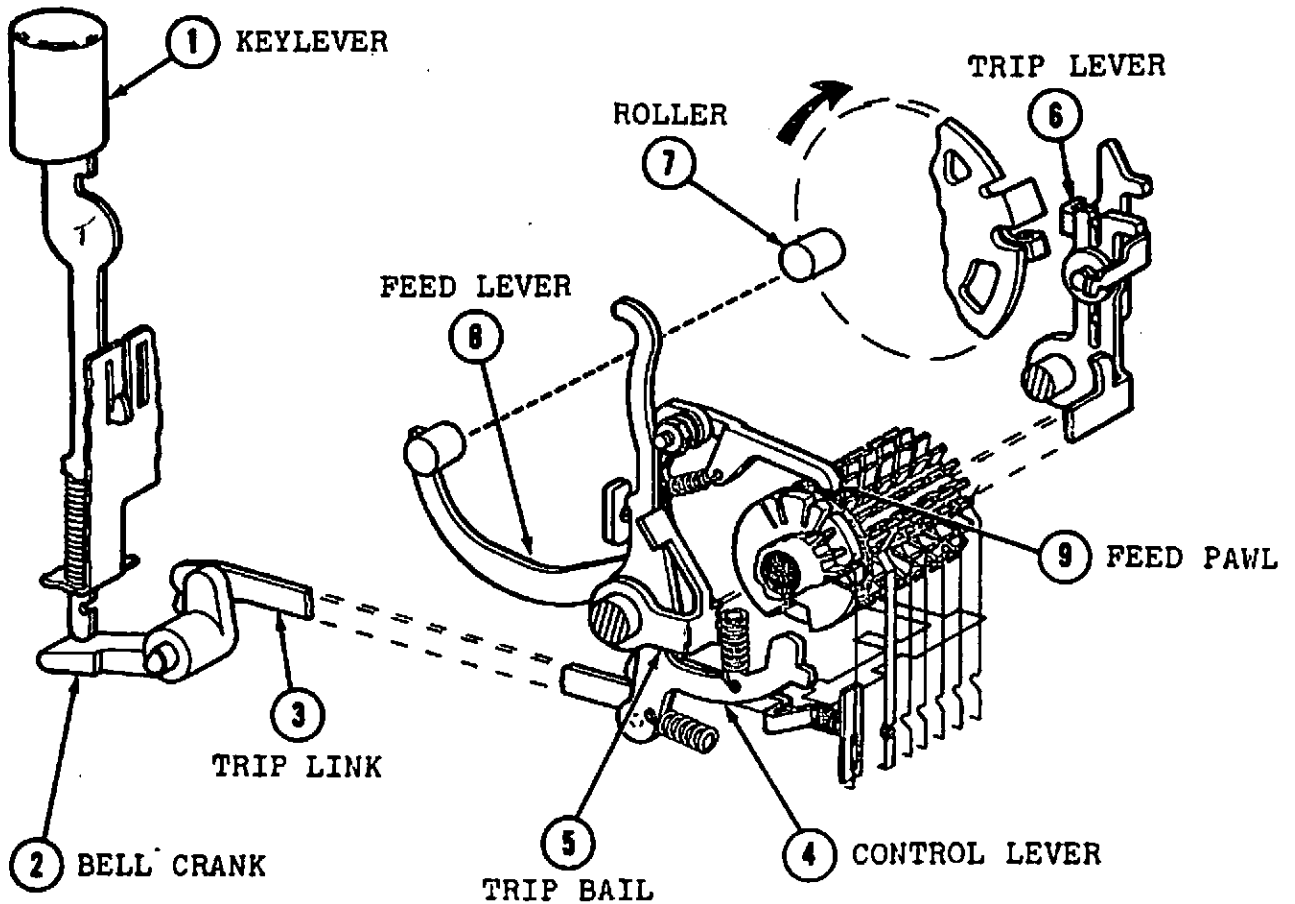

Depression of KEYLEVER (1) operates BELL CRANK (2) down. TRIP LINK (3) moves forward rotating CONTROL LEVER (4) clockwise out of indent in start cam.

CONTROL LEVER (4) also drives TRIP BAIL (5) and attached TRIP LEVER (6) to the rear engaging distributor clutch.

As clutch cycle begins, ROLLER (7) allows FEED LEVER (8) to move up, operating the FEED PAWL (9) to the rear to select a new tooth on ratchet. Late in clutch cycle, ROLLER (7) drives FEED LEVER (8) down, pulling FEED PAWL (9) forward, advancing DRUM one unit.

Contact wires sense tines on drum as it is rotated. This action continues until CONTROL LEVER (4) finds an indent in start cam.

*Success is nothing but a good idea coupled with hard work*

RECEIVING (WRU)

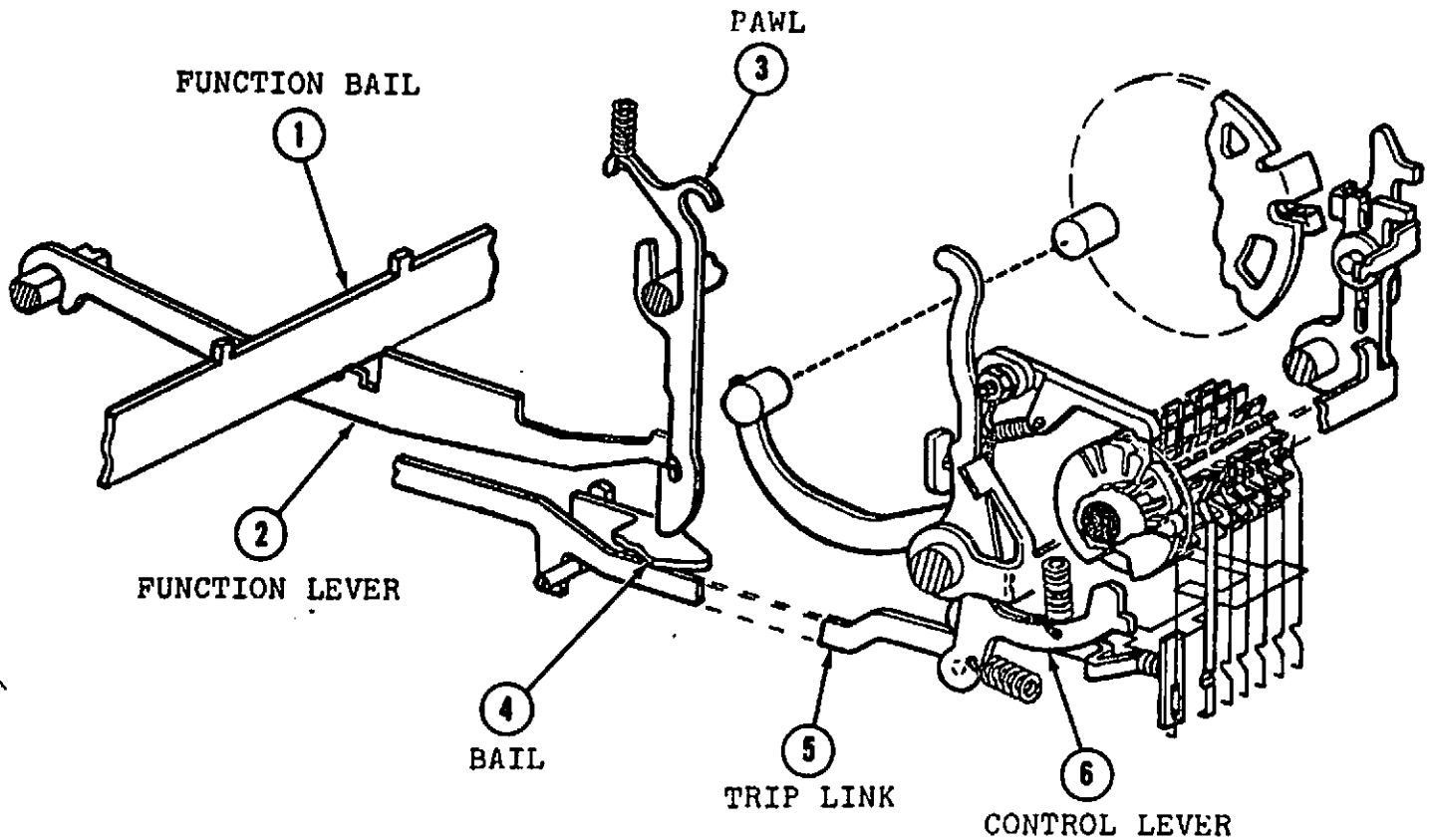

Printer is conditioned by a remote station for Answer Back function. As FUNCTION BAIL (1) raises, the A. B. FUNCTION LEVER (2) moves up and is latched by A. B. PAWL (3). FUNCTION BAIL (1) and FUNCTION LEVER (2) return down, pulling A. B. PAWL (3) down to operate A. B. BAIL (4).

As A. B. BAIL (4) pivots, TRIP LINK (5) moves forward rotating the CONTROL LEVER (6) clockwise to initiate the A. B. feed and sensing action.

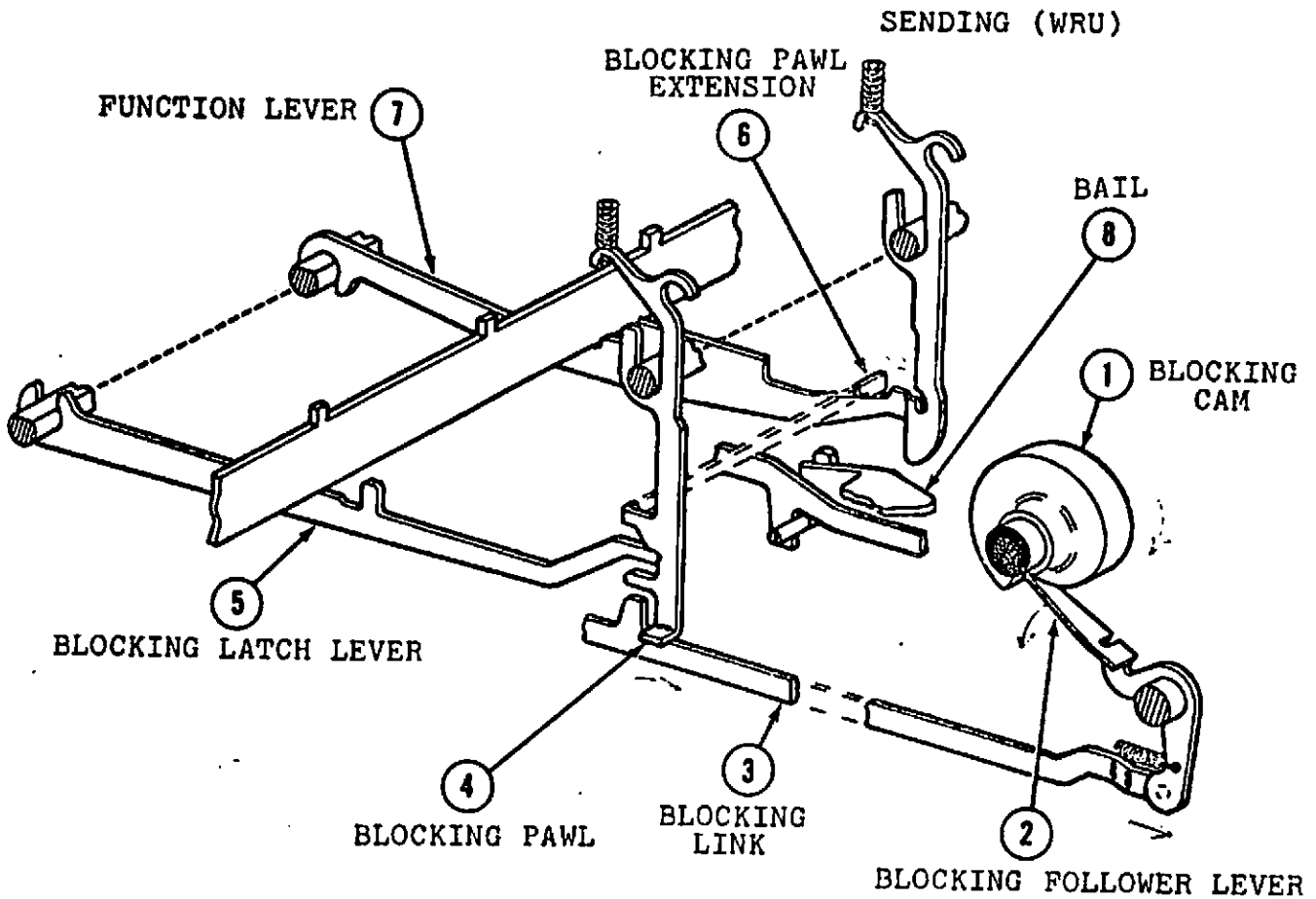

Originating (WRU) on local keyboard activates the local distributor, which transmits to the local printer and a remote station simultaneously. Only the remote stations Answer Back should respond.

**Local Blocking Action:**

As the local distributor clutch cycles, BLOCKING CAM (1) rotates clockwise, driving BLOCKING FOLLOWER LEVER (2) down. BLOCKING LINK (3) moves toward the rear pulling BLOCKING PAWL (4) rearward. BLOCKING LATCH LEVER (5) moves up, holding the BLOCKING PAWL (4) in position. BLOCKING PAWL EXTENSION (6) blocks the A. B. FUNCTION LEVER (7) as it tries to operate. A. B. BAIL (8) remains unoperated and the local A. B. mechanism fails to respond.

Diplomacy is the art of  
letting someone else  
have your way

## AUTOMATIC ANSWER BACK

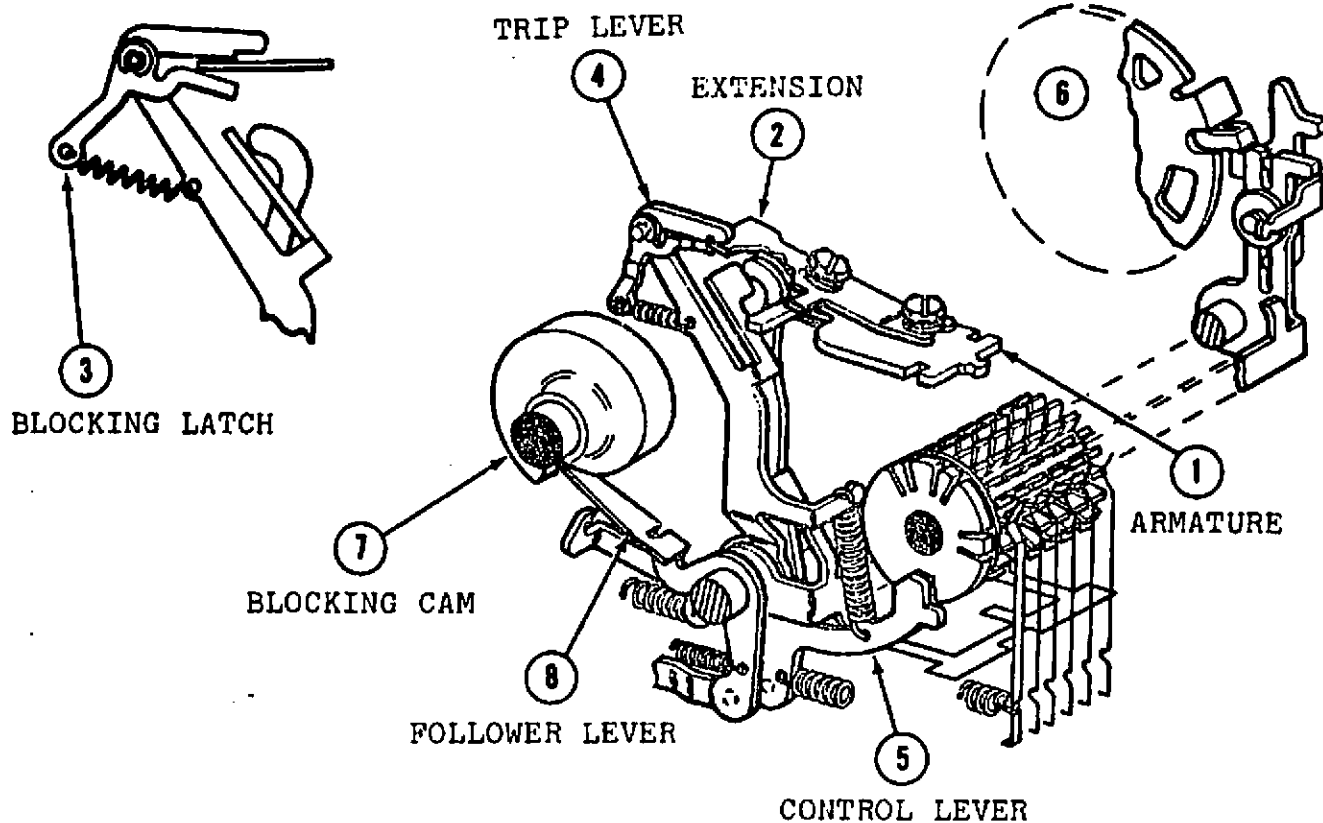

Current is applied to Answer Back coil. (Connect)

ARMATURE (1) with EXTENSION (2) is attracted downward. BLOCKING LATCH (3) is pivoted clockwise and undertravels EXTENSION (2).

TRIP LEVER (4) overtravels EXTENSION (2). Trip lever tab drives CONTROL LEVER (5) clockwise.

DISTRIBUTOR CLUTCH (6) engages, drum rotation begins.

Late in first clutch cycle, BLOCKING CAM (7) is rocked forward to clear the EXTENSION (2) and to release CONTROL LEVER (5). BLOCKING LATCH (3) pivots up to hold TRIP LEVER (4) forward.

Drum rotation continues until an indent is presented to CONTROL LEVER (5).

Current is removed from coil. (Disconnect) ARMATURE (1) with EXTENSION (2) moves up to hold TRIP LEVER (4).

## SENSING AND SUPPRESSION

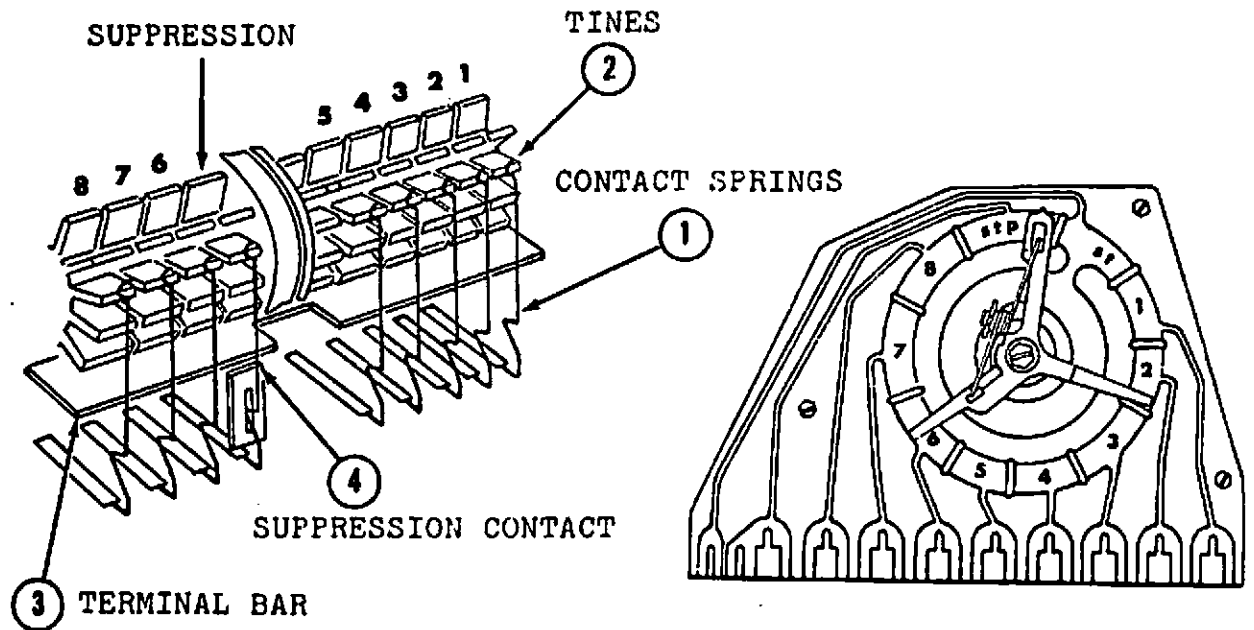

Answer back contacts are wired in parallel with distributor segments.

Answer back contacts are wired in parallel with distributor segments.

CONTACT SPRINGS (1) sense TINES (2) on drum as it rotates.

Where no tine exists, the CONTACT SPRING (1) moves in against TERMINAL BAR (3) completing circuit path to a segment (marking).

Where a tine exists, the CONTACT SPRING (1) is blocked and does not touch TERMINAL BAR (3) (spacing).

The removal of a suppression tine in any character row, permits the SUPPRESSION CONTACT (4) to close, during the sensing sequence of that character row.

With contact closed, a current condition exists on signal loop, blinding the (start) and (intelligence) elements being transmitted. Suppression can also be used to eliminate coding errors or surplus rows on drum.

If at first you don't  
succeed, you're like  
most other people

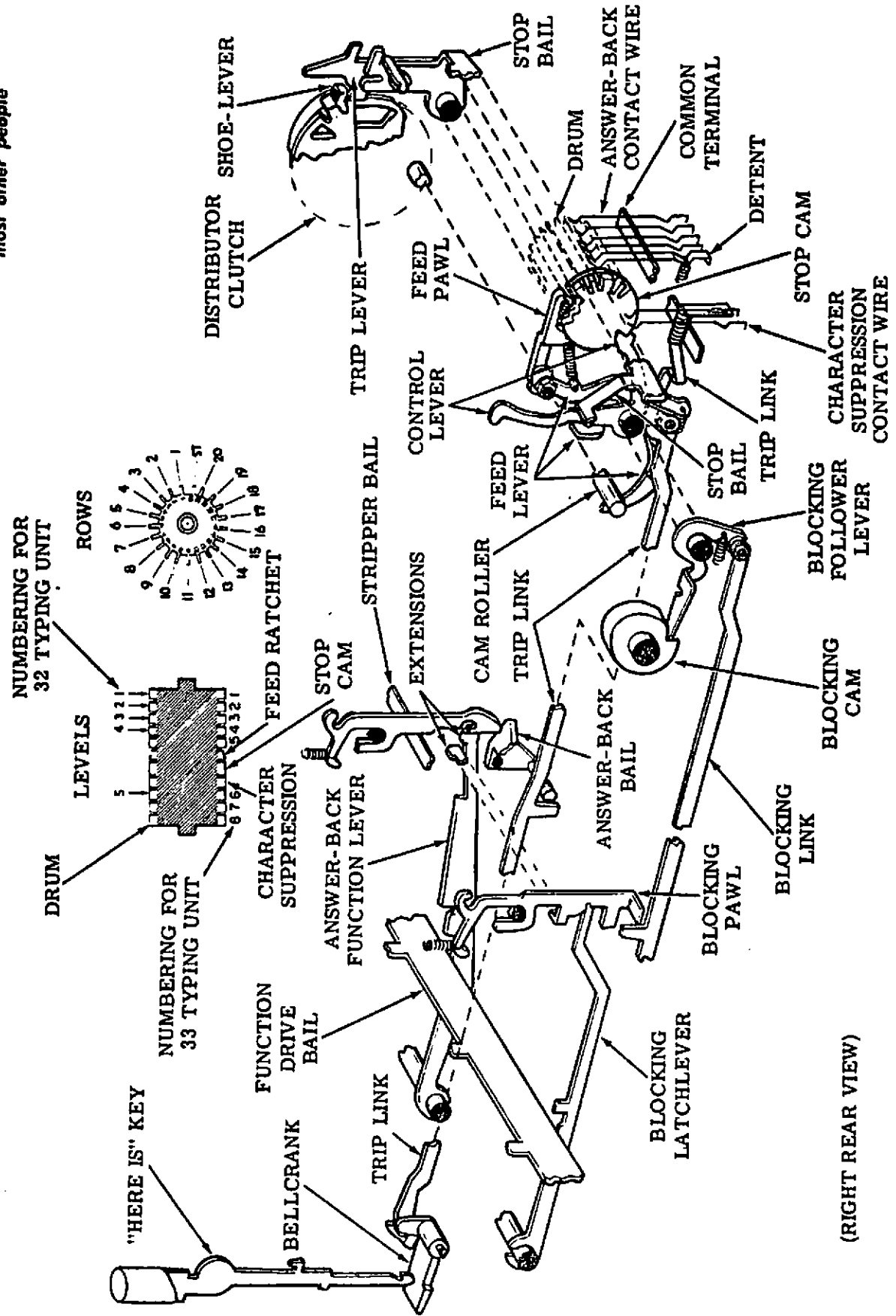

Answer-Back Mechanism

(RIGHT REAR VIEW)

## MODEL 33 PRINTER

See the following General System Practices for related printer information:

- A. 574-122-100 -- Principles of Operation
- B. 574-122-700 -- Adjustments
- C. 574-122-701 -- Lubrication
- D. 574-122-702 -- Disassembly and Reassembly
- E. 574-122-800 -- Parts

## **TAPE PUNCH**

The tape punch, in conjunction with the selector and codebar mechanisms on the typing unit, provides facilities for perforating messages in paper tape. The messages are received as start-stop signals from the call control unit and are converted to mechanical motions that punch corresponding code holes in the tape.

The punch includes the following components:

- (a) A drive mechanism which receives motion from the function rocker shaft on the typing unit and distributes it to other mechanisms.
- (b) An intelligence-transfer mechanism which receives intelligence from the codebar mechanism on the typing unit.
- (c) A tape-punching mechanism which, under the control of the intelligence-transfer mechanism, perforates feed and code holes in the tape by means of punch pins located in a holder.
- (d) A tape feed and guide mechanism that advances the tape by means of rollers and a feed pawl and ratchet arrangement.
- (e) A base casting which is attached to the typing unit base and provides mounting facilities for the various mechanisms.
- (f) A supply reel which accommodates a roll of blank tape.
- (g) A pan casting and 2-piece plastic cover which provides a protective and decorative enclosure for the tape punch.
- (h) A metallic chad container which collects the paper (chad) punched out by punch pins.

The following four pushbuttons are provided:

- (a) ON - Turns the tape punch on.
- (b) OFF - Turns the tape punch off.
- (c) REL (Release) - Releases the tape feed and guide mechanism so that tape can be easily removed from the tape punch.
- (d) B. SP. (Backspace) - Backspaces tape one combination of code holes.

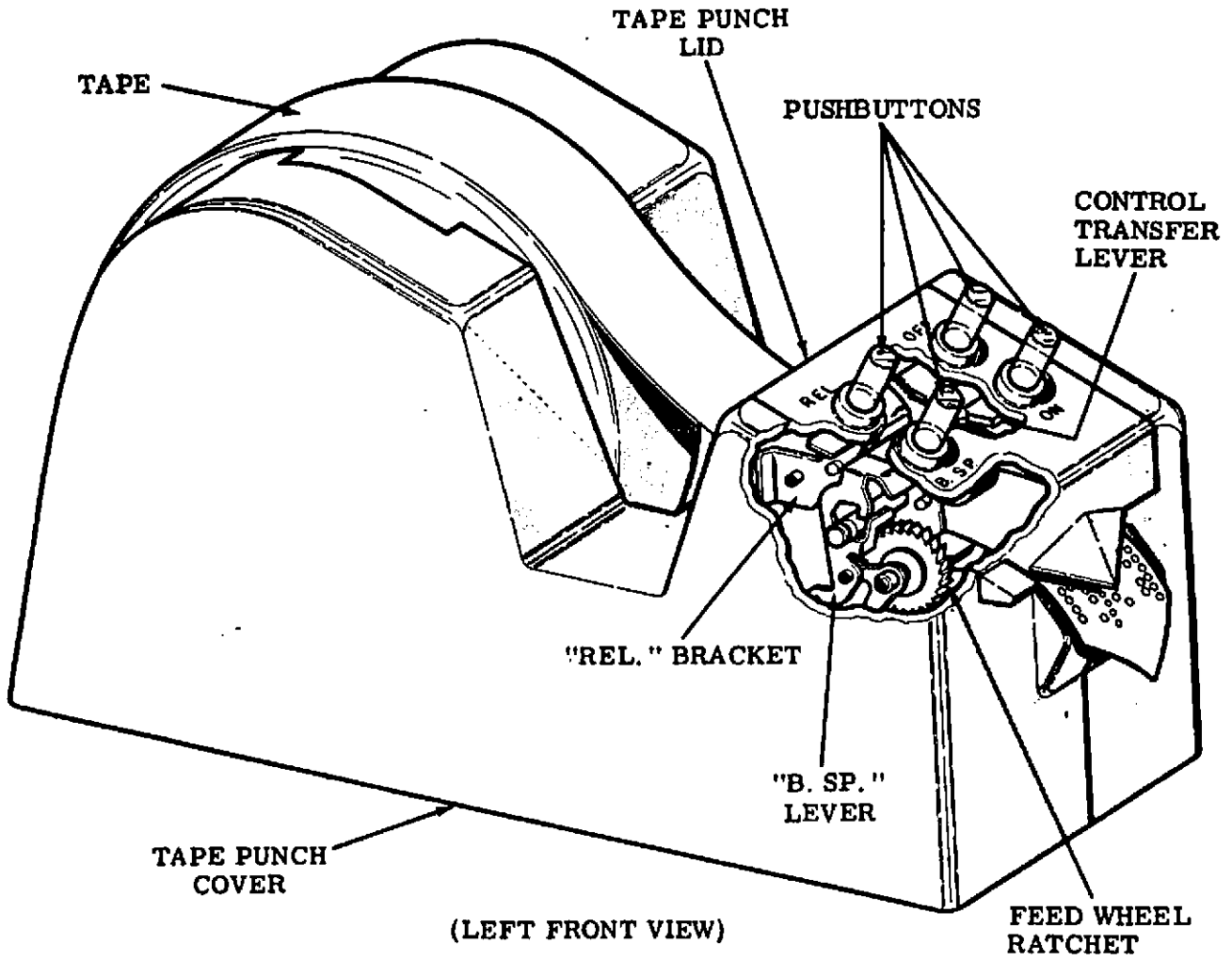

- Control Mechanism

*Elephants and mis-treated customers have long memories*

## POWER BAIL

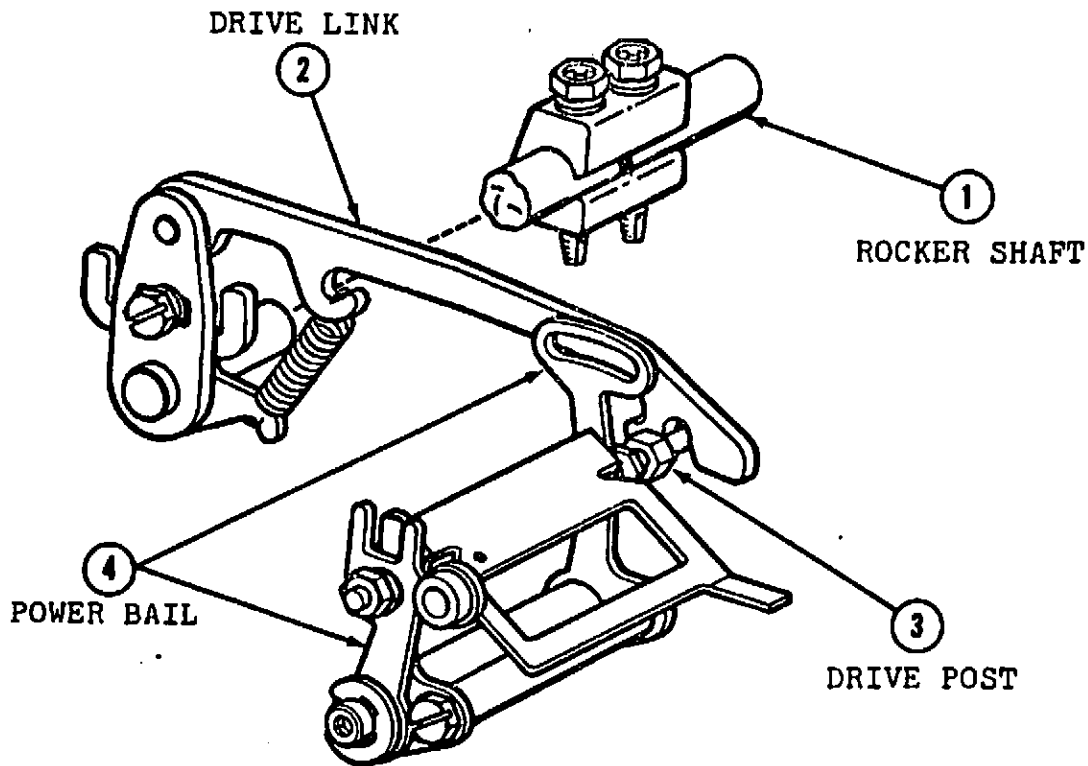

The tape punch receives drive motion from the printer's function rocker shaft.

Three distinct movements occur with each cycle of operation. Counterclockwise rotation of ROCKER SHAFT (1), operates DRIVE LINK (2) to the rear. DRIVE LINK (2) acts on DRIVE POST (3) to rock the POWER BAIL (4) to the rear.

Clockwise rotation of ROCKER SHAFT (1) operates DRIVE LINK (2) forward, rocking POWER BAIL (4) forward.

A slight counterclockwise rotation of ROCKER SHAFT (1) returns POWER BAIL (4) upright and all motion terminates.

## CONTROL

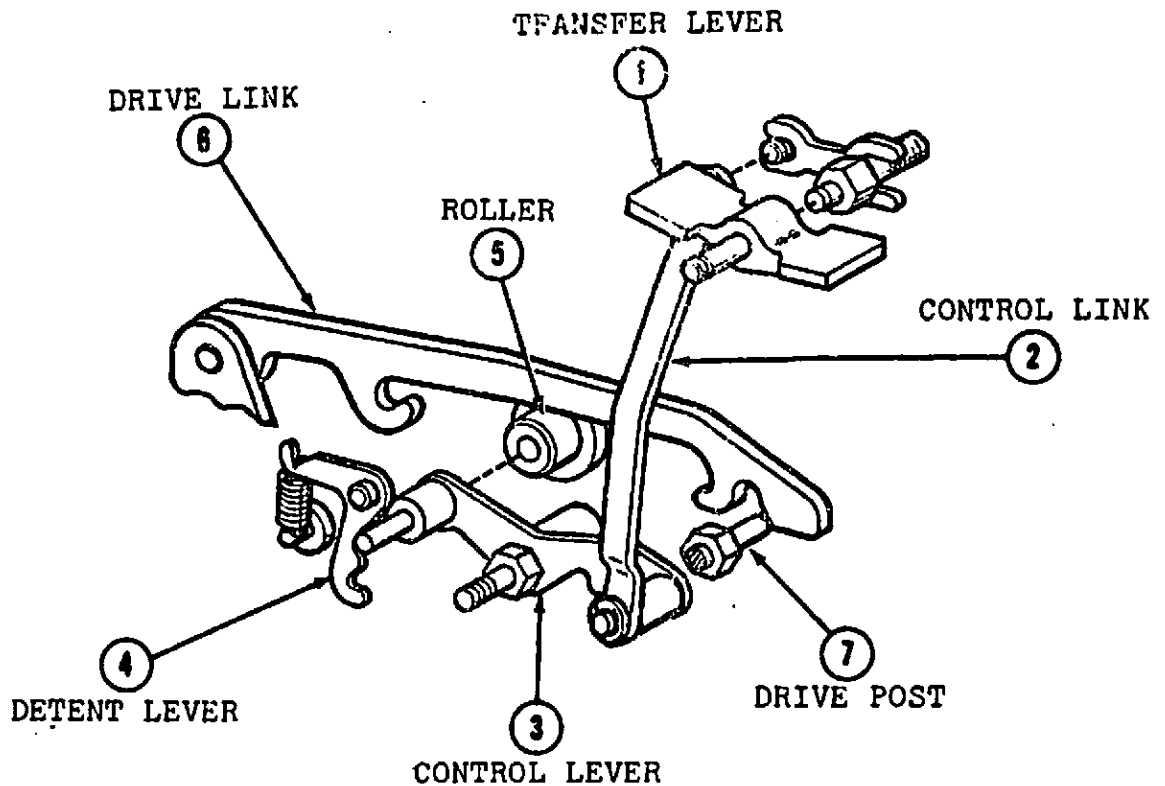

ON and OFF pushbuttons are located in tape punch lid.

ON and OFF pushbuttons are located in tape punch lid. The depression of ON button drives the forward half of TRANSFER LEVER (1) down, drawing CONTROL LINK (2) up. CONTROL LEVER (3) rotates counterclockwise where it is held by DETENT LEVER (4). A ROLLER (5) attached to CONTROL LEVER (3) allows DRIVE LINK (6) to move down and engage DRIVE POST (7).

To raise LINK (6), reverse action occurs as OFF button strikes rear half of TRANSFER LEVER (1).

Just when you make  
both ends meet, some-  
body moves the ends

# SENSING

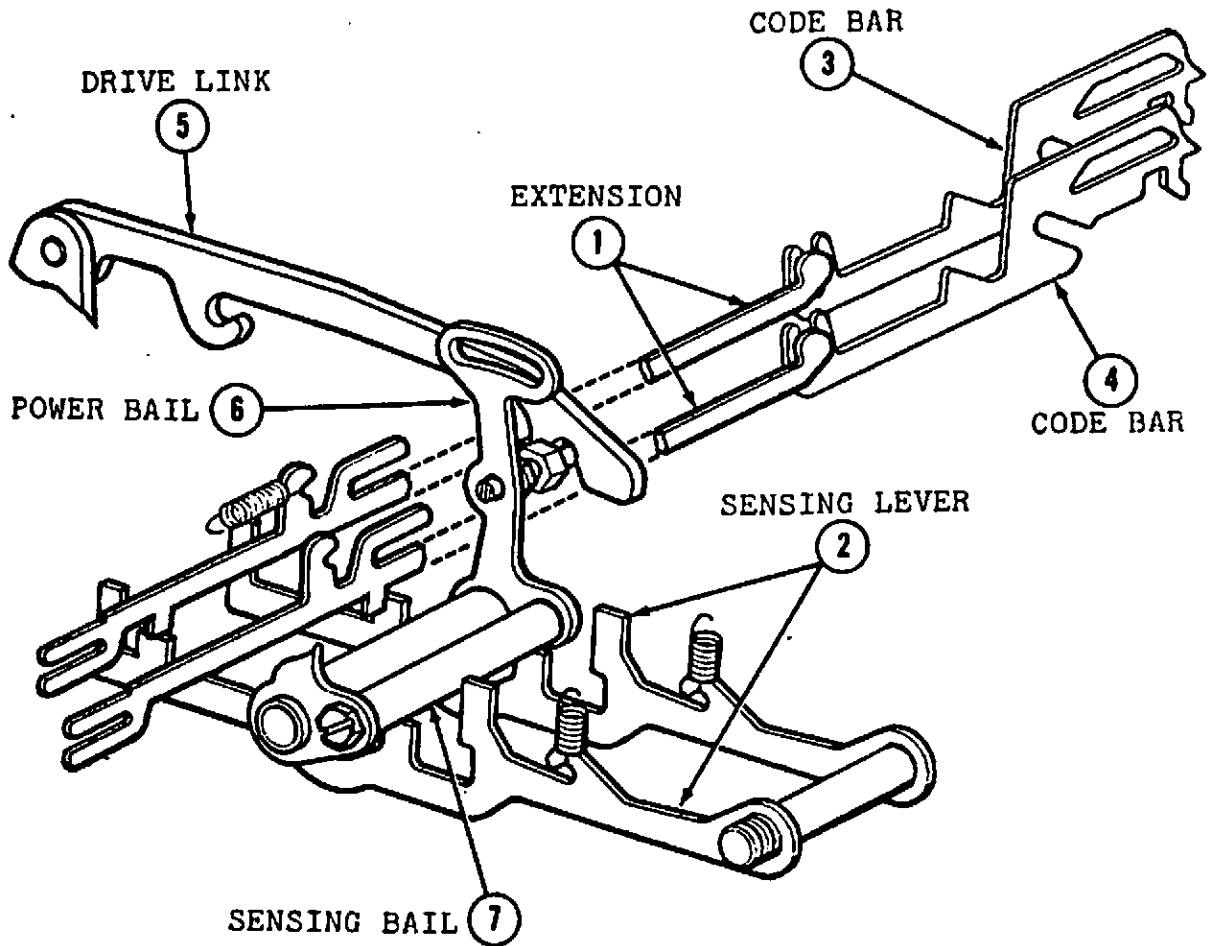

Intelligence arranged in printer code bars is transferred through extensions into the tape punch.

Intelligence arranged in printer code bars is transferred through extensions into the tape punch.

Each EXTENSION (1) contains a tab on its underside which is associated with a SENSING LEVER. (2)

CODE BAR (3) held right, tab remains over sensing lever.

CODE BAR (4) shifted left, removes tab from over sensing lever.

Function clutch engages, function rocker shaft begins rotating.

DRIVE LINK (5) moves rearward, rocking POWER BAIL (6) to the rear.

SENSING BAIL (7) raises, allowing SENSING LEVERS (2) to pivot up and sense EXTENSIONS (1). Those which do not encounter tab, move up. Those blocked by tab, remain down.

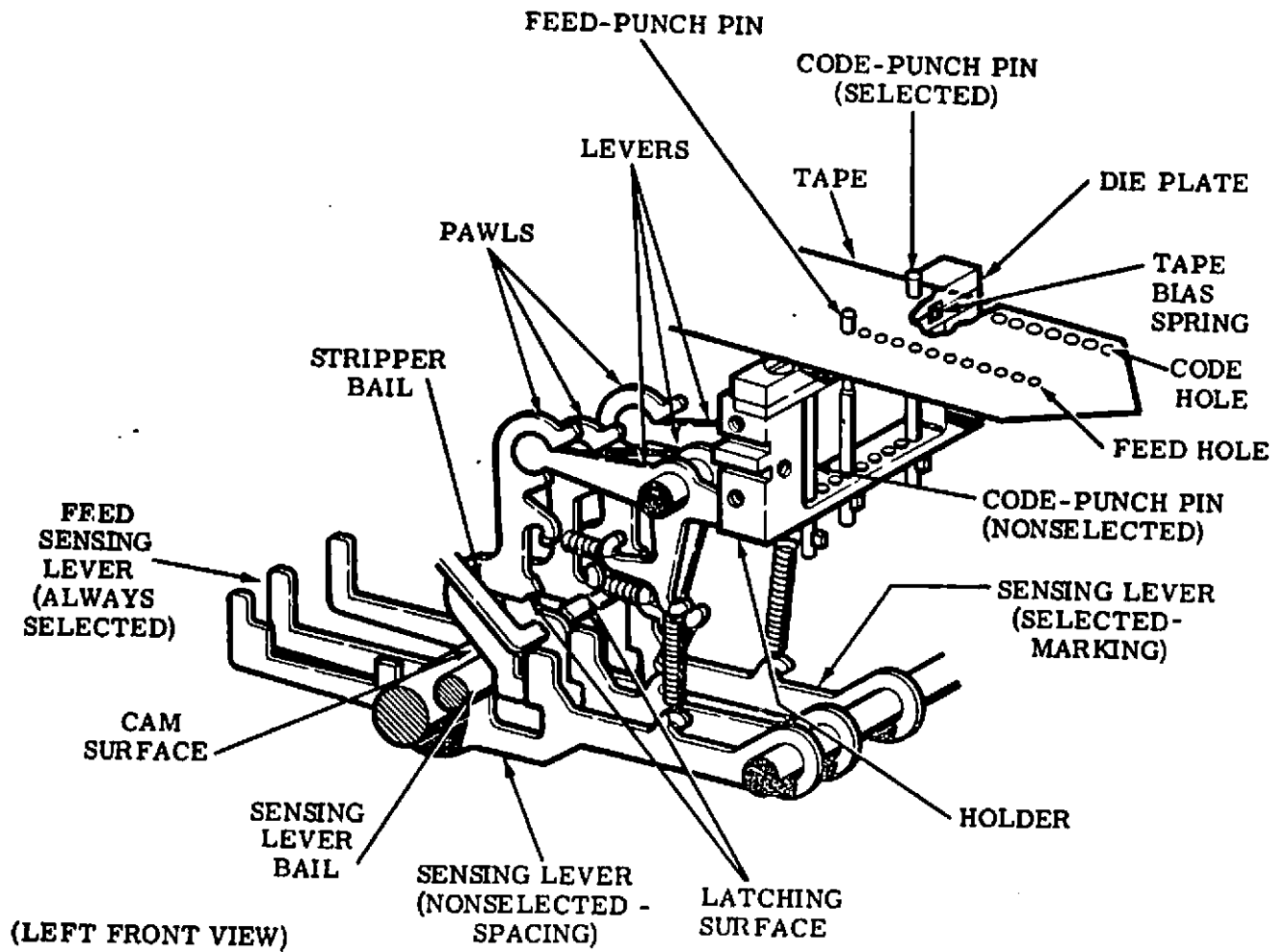

- Tape Punch Mechanism

*Promises, like customers, should be kept after they are made*

# PUNCHING TAPE

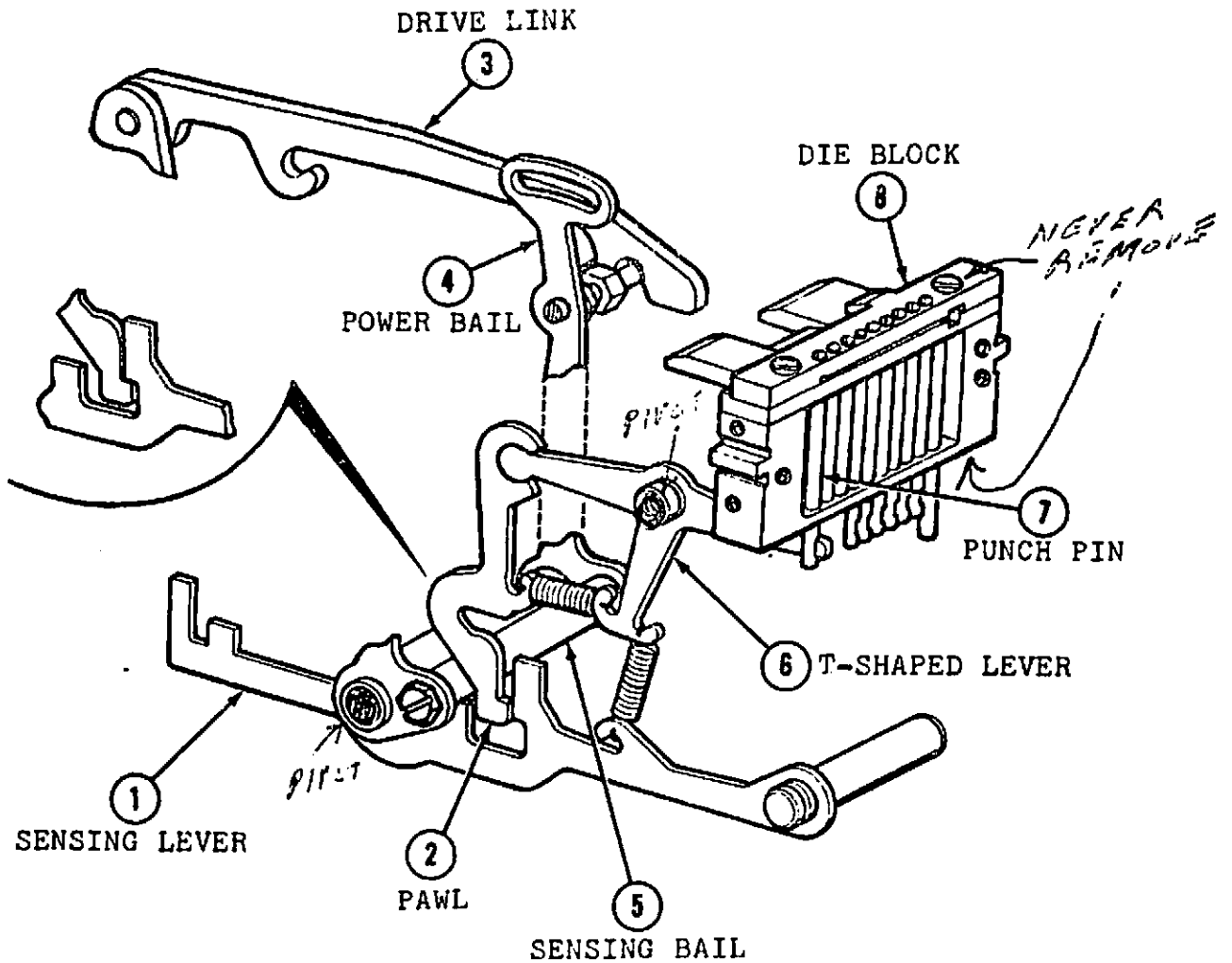

A SENSING LEVER (1) which moves up, selects and latches a PAWL (2).  
The DRIVE LINK (3) begins moving forward rocking POWER BAIL (4)  
forward. SENSING BAIL (5) is operated down, driving SENSING LEVER (1)  
(1) with latched PAWL (2) down. T-SHAPED LEVER (6) rotates  
counterclockwise, forcing PUNCH PIN (7) through paper tape which  
rests in DIE BLOCK (8).

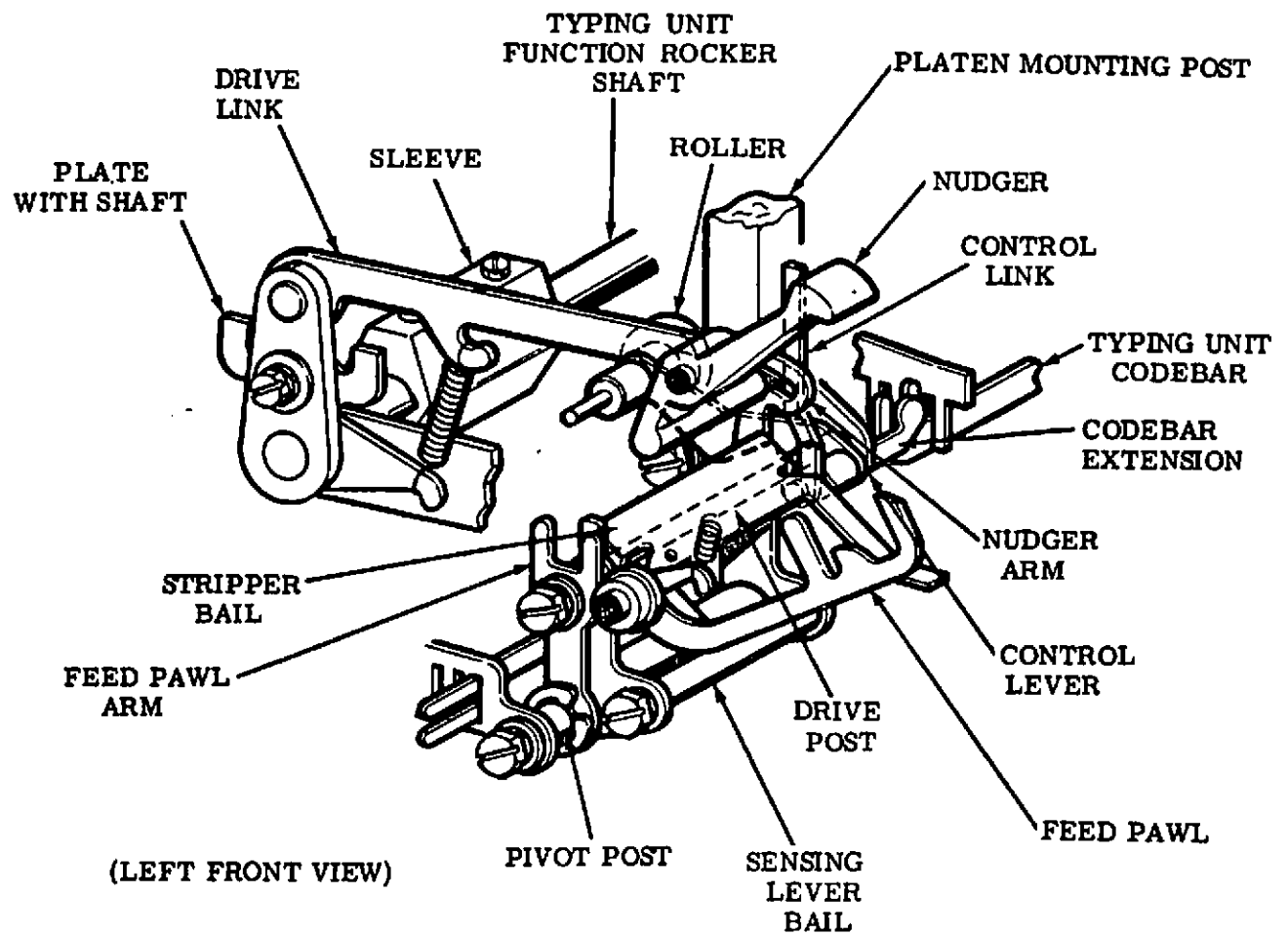

- Drive Link Mechanism and Drive Mechanism

*Instead of the tricks of the trade, why not learn the trade?*

## STRIPPER BAIL

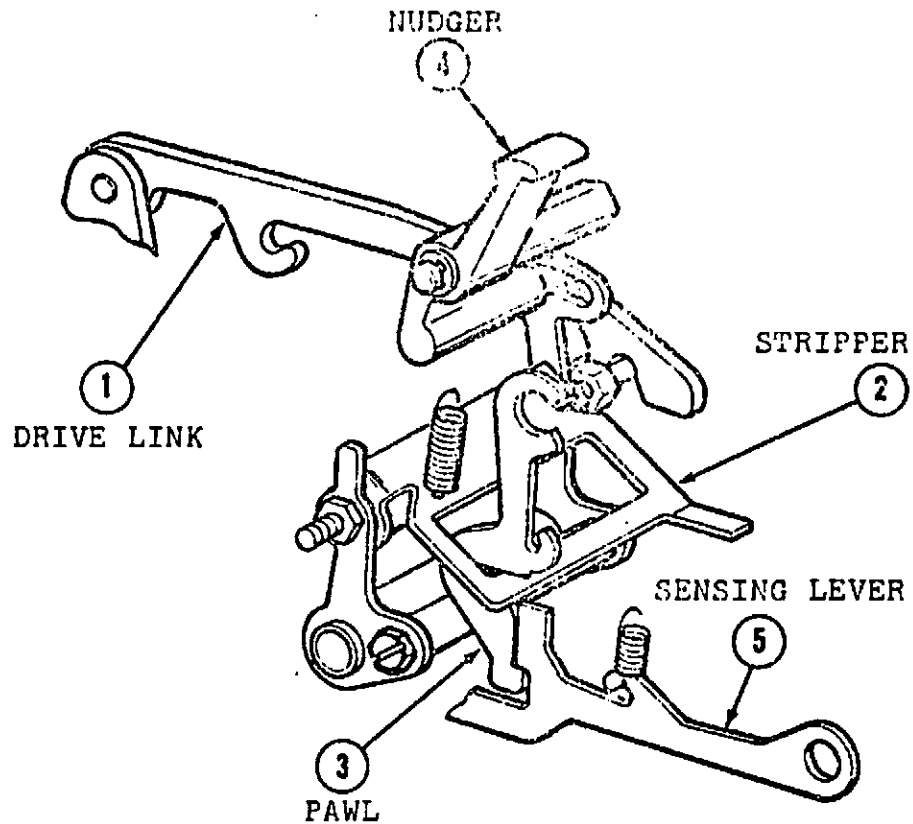

As DRIVE LINK (1) moves forward to punch tape, a STRIPPER BAIL (2) is operated forward and through its bias spring it engages a latching surface on the underside of the PAWL (3).

Also, a cam profile directs counterclockwise motion into the NUDGER (4) which gently nudges the tape to index the tape roll a small amount. (frees tape)

DRIVE LINK (1) returns slightly rearward and STRIPPER BAIL (2) strips latched PAWL (3) from SENSING LEVER (5). Pawl, T-shaped lever, and punch pin return to their unoperated position, and all action terminates.

## FEED ACTION

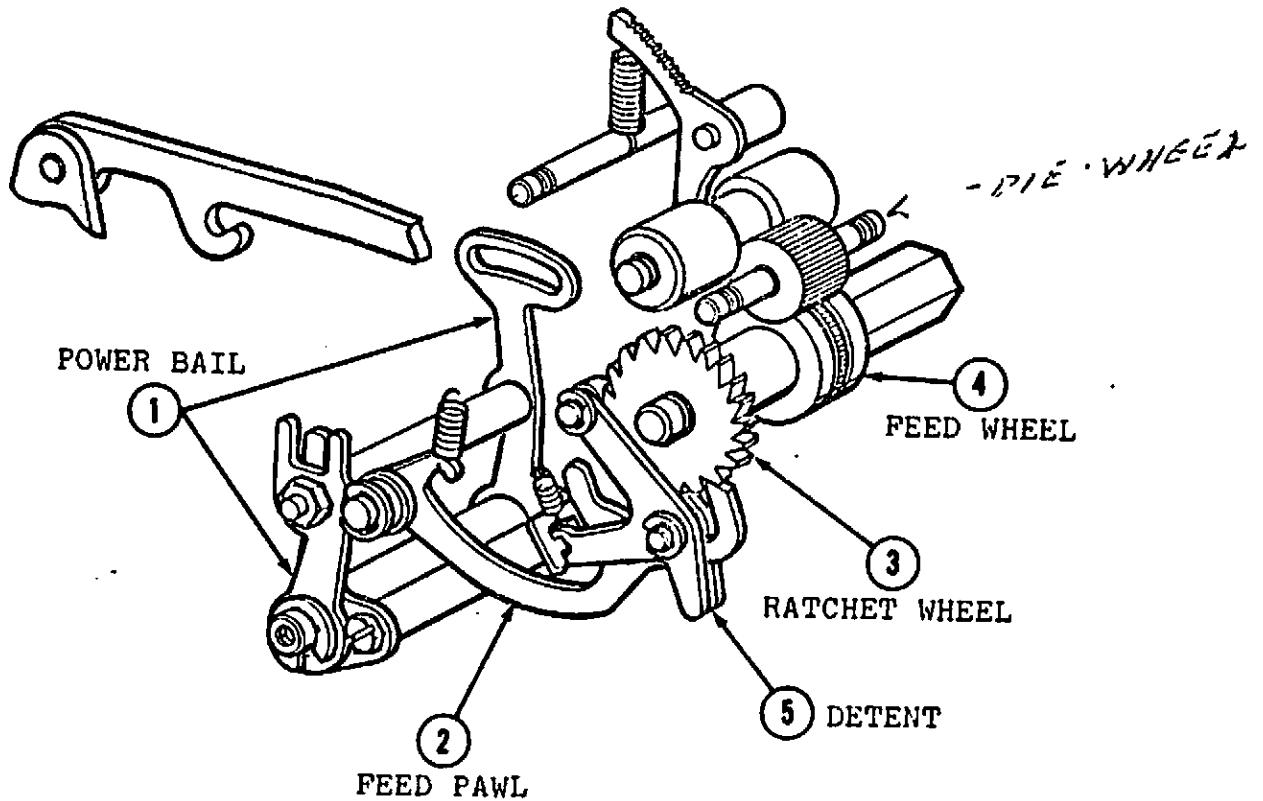

*Some people try to  
hold a job by sitting  
on it*

As a cycle begins, the POWER BAIL (1) rocks to the rear and operates the FEED PAWL (2) to act on the RATCHET WHEEL (3). This action rotates FEED WHEEL (4) to advance tape one tenth of an inch.

A DETENT MECHANISM (5) holds RATCHET WHEEL (3) in its operated position.

Midway through cycle, the forward movement of POWER BAIL (1) operates FEED PAWL (2) forward to select a new tooth on RATCHET WHEEL (3).

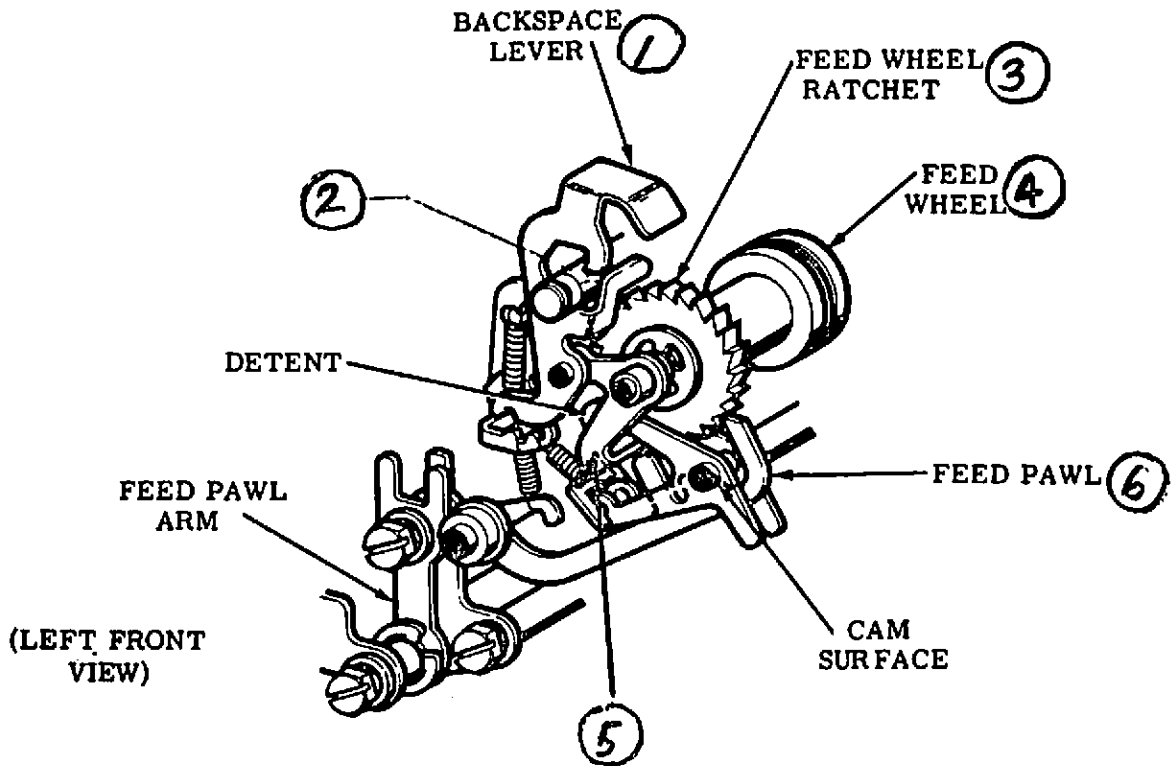

Feed Wheel Mechanism (Tape Feed Mechanism)

Backspace button on tape punch lid is depressed, driving BACKSPACE LEVER (1) down.

Two actions occur simultaneously:

An ARM (2) on BACKSPACE LEVER (1) engages and rotates the RATCHET (3) and attached FEED WHEEL (4) in a counterclockwise direction, drawing the tape back one unit.

Also, an associated LEVER (5) is pivoted to move the FEED PAWL (6) away from RATCHET (3).

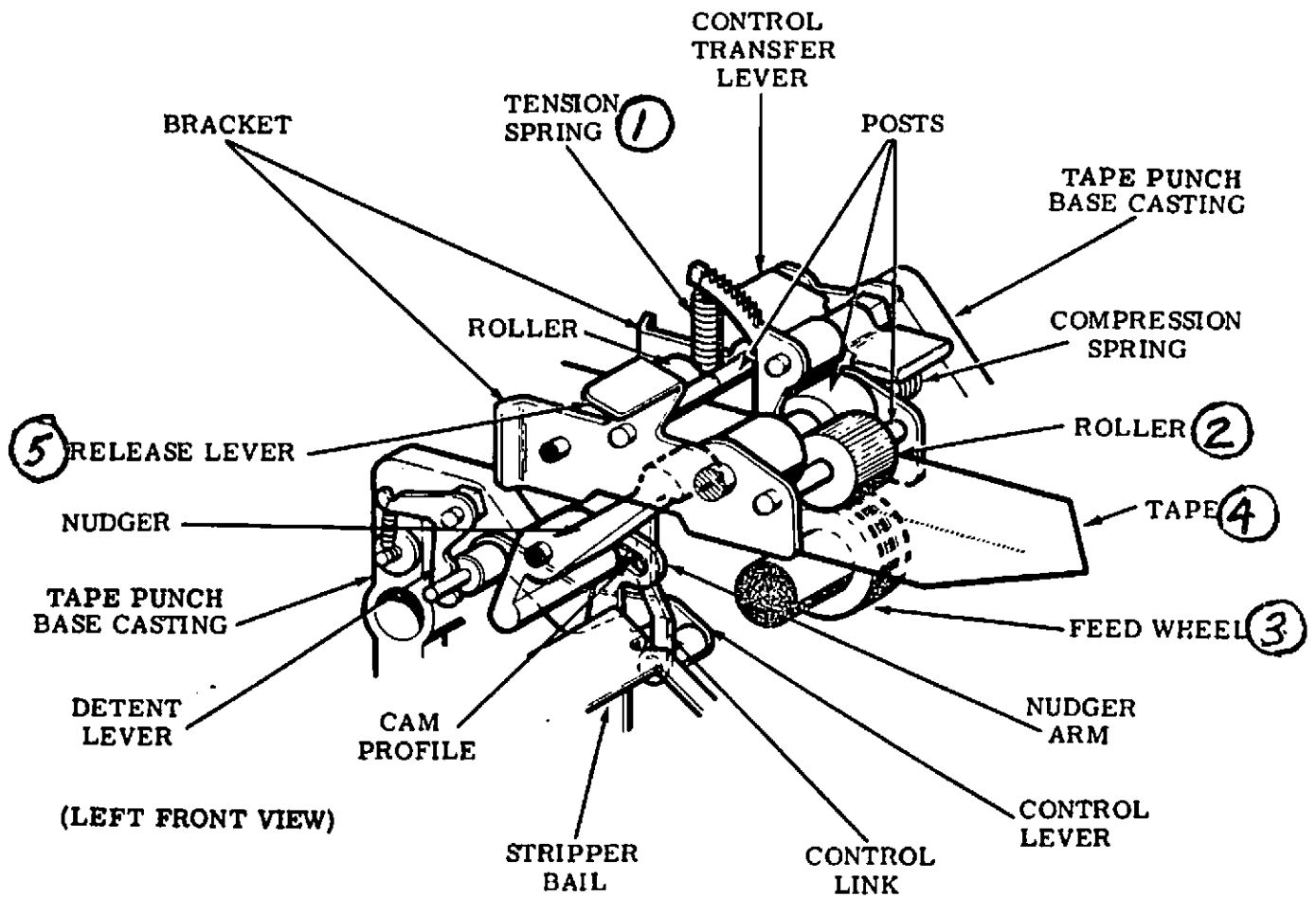

Tape Guide Assembly (Tape Feed Mechanism)

*The only people who never fail are those who never try*

A tension spring (1) serves to hold the KNURLED ROLLER (2) against the FEED WHEEL (3) as TAPE (4) is fed through. This combination provides adequate tape spacing. (Ten holes per inch.)

Depression of REL button on punch lid, pushes down on RELEASE LEVER (5), disengaging KNURLED ROLLER (2) from FEED WHEEL (3). Easy tape insertion or removal is thereby attained.

## MODEL 33 TAPE PUNCH

See the following General System Practices for additional information on the tape punch:

- A. 574-125-100 -- Principles of Operation
- B. 574-125-700 -- Adjustments
- C. 574-125-701 -- Lubrication
- D. 574-125-702 -- Disassembly and Reassembly
- E. 574-125-800 -- Parts

## TAPE READER

The tape reader, in conjunction with the distributor mechanism on the typing unit, provides facilities for transmitting messages from perforated tape.

The complete tape reader package includes the following components:

- (a) A tape-sensing mechanism which converts code holes in the tape to corresponding positions in a set of contact springs. The holes are sensed by pins which operate the contact springs. The positions of the contact springs are converted to start-stop signals by the distributor mechanism.
- (b) A feed mechanism which advances the tape after a combination of code holes has been read. A feed pawl and ratchet arrangement rotates a feed wheel whose pins engage feed holes in the tape. The tape feeds from rear to front and is held down on the sensing pins and feed wheel by a hinged tape lid which may be opened to facilitate tape threading.
- (c) A feed magnet and armature arrangement which supplies motion for the sensing and feed mechanisms. It is pulsed by a contact on the distributor mechanism.
- (d) A magnet-controlled clutch-trip mechanism which actuates the distributor mechanism. It is mounted above the distributor on the typing unit.
- (e) A power pack, mounted in the enclosure of the stand, which provides current rectification for the feed magnet. It is protected by a metal housing.
- (f) A cable which interconnects the tape reader with the power pack, the magnet pulsing contact, and the call control unit.
- (g) Tape-out and tight-tape mechanisms which will stop the tape reader when it runs out of tape or when the tape becomes taut.
- (h) A free-wheeling mechanism which disengages the feed wheel and tape-out mechanisms and permits the tape to be moved freely through the tape reader.
- (i) A frame which is mounted on the typing unit's subbase and provides mounting facilities for the other mechanisms, excluding the power pack and clutch-trip mechanism.
- (j) A base casting and plastic cover which provide a protective and decorative enclosure for the tape reader.
- (k) The auxiliary ASR power supply is mounted in the enclosure of the stand. It is used in the off-line mode, to provide 115 volts on the tape reader, keyboard, answer-back, and distributor contacts only when a tape reader is used. When the tape reader is not used, a dummy plug with a jumper wire is inserted in position "R2" at the rear of the call control unit.

*Conscience: the thing  
that hurts when every-  
thing else feels good*

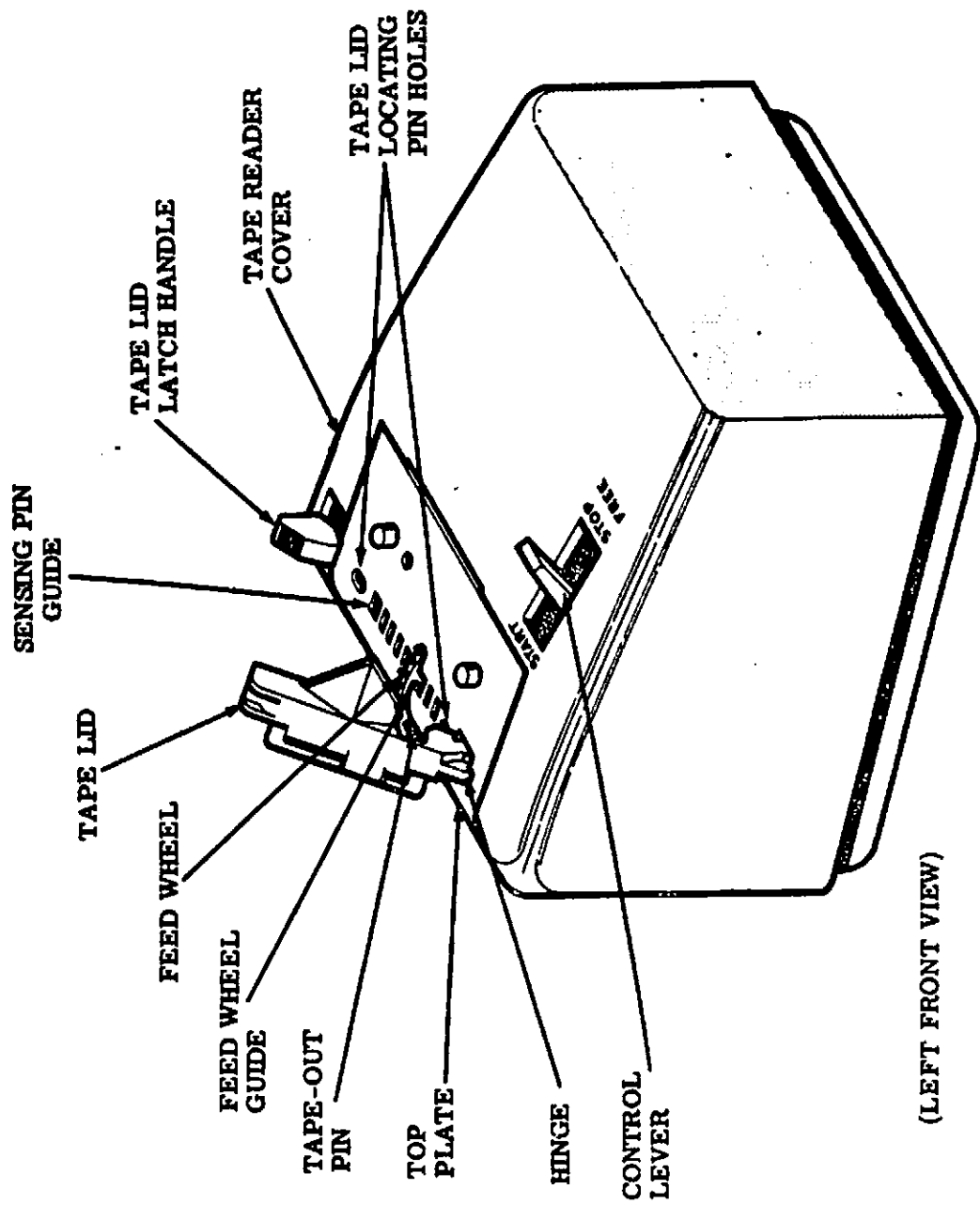

(LEFT FRONT VIEW)

- Tape Reader

574-124-100 MOD. 32 & 33 TAPE READER

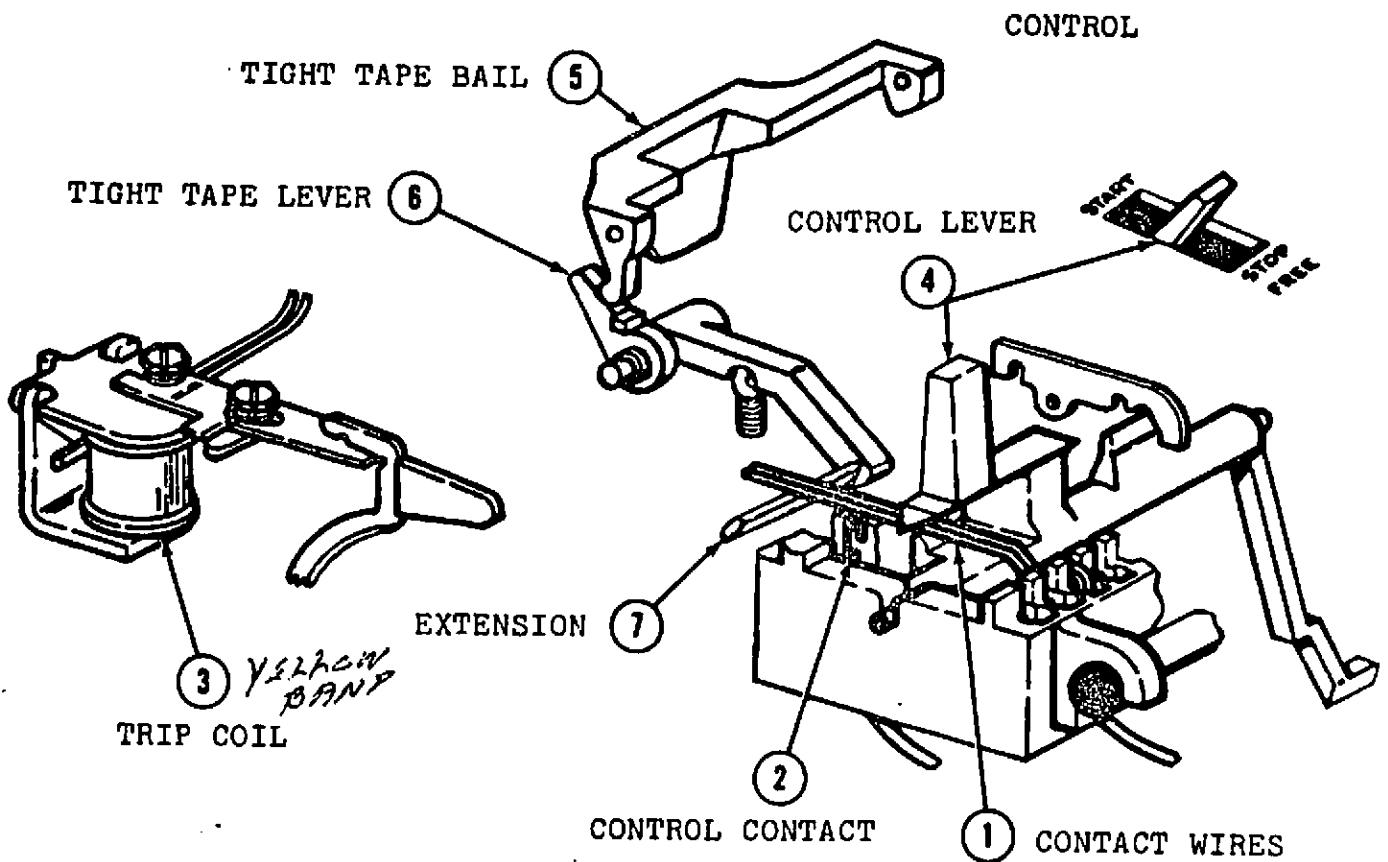

CONTACT WIRES (1) and CONTROL CONTACT (2) are wired in series with DISTRIBUTOR CLUTCH TRIP COIL (3) and power source. The three positions for CONTROL LEVER (4) are START, STOP, and FREE. Operating CONTROL LEVER (4) to START allows CONTACT WIRES (1) to move down and touch CONTROL CONTACT (2). TRIP COIL (3) becomes energized.

Operating to STOP, CONTACT WIRES (1) are lifted by CONTROL LEVER (4). Circuit opens, TRIP COIL (3) de-energizes.

A taut or twisted tape entering the tape reader, will pivot the TIGHT TAPE BAIL (5) upward.

The TIGHT TAPE BAIL (5) engages and rotates a TIGHT TAPE LEVER (6) counterclockwise.

An EXTENSION (7) on TIGHT TAPE LEVER (6) raises, lifting CONTACT WIRES (1) from CONTROL CONTACT (2). TRIP COIL (3) de-energizes.

Drive carefully. The life  
you save may be mine

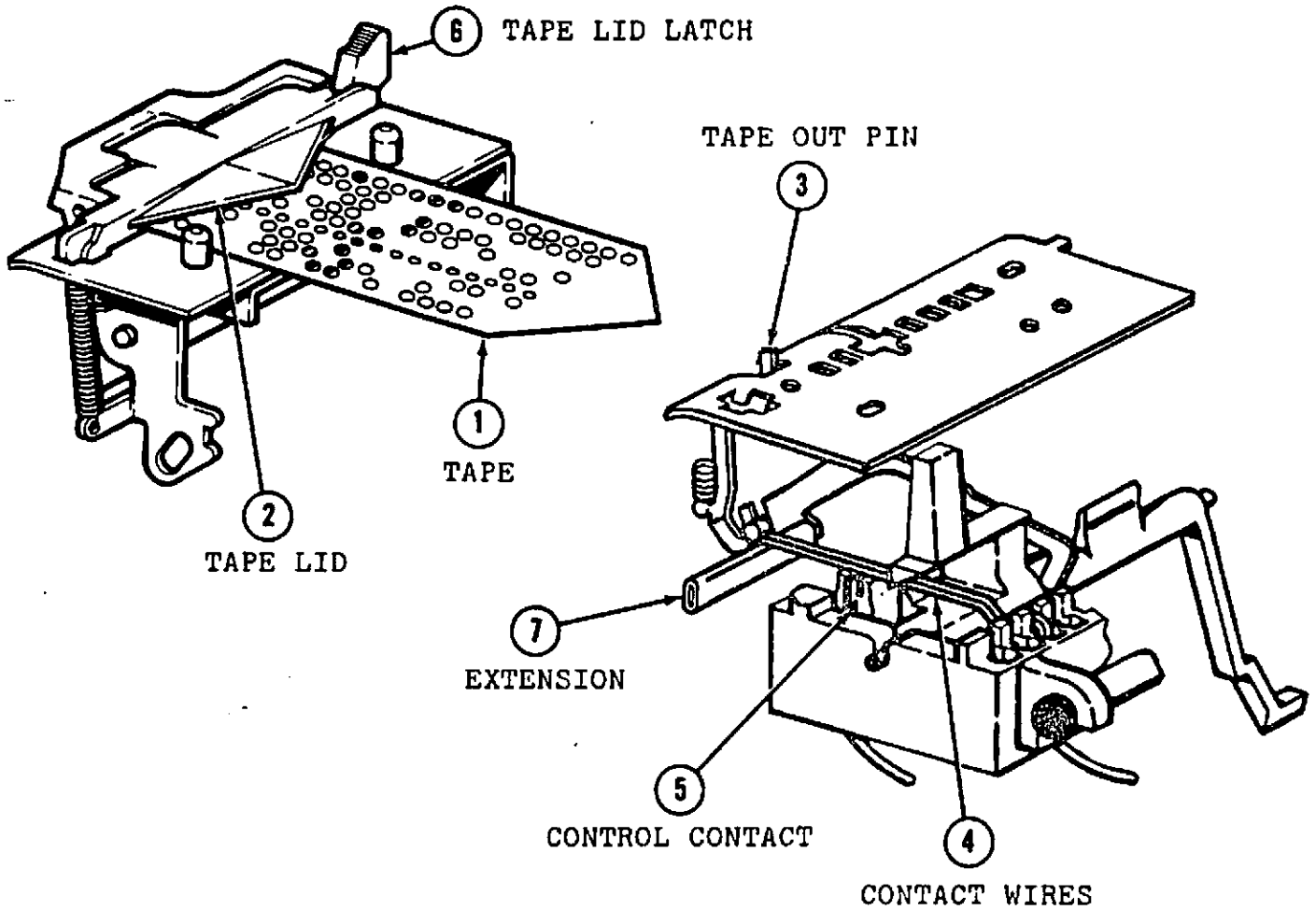

With TAPE (1) in reader, and TAPE LID (2) closed, the TAPE OUT PIN (3) is held down. CONTACT WIRES (4) make with CONTROL CONTACT (5). Trip coil is energized.

Operating TAPE LID LATCH (6), TAPE LID (2) swings open. TAPE OUT PIN (3) moves up allowing its EXTENSION (7) to raise CONTACT WIRES (4) from CONTROL CONTACT (5). Trip coil de-energizes. Also, as TAPE OUT PIN (3) senses the end of a tape, it raises and lifts CONTACT WIRES (4) from CONTROL CONTACT (5).

READER TRIP LEVER

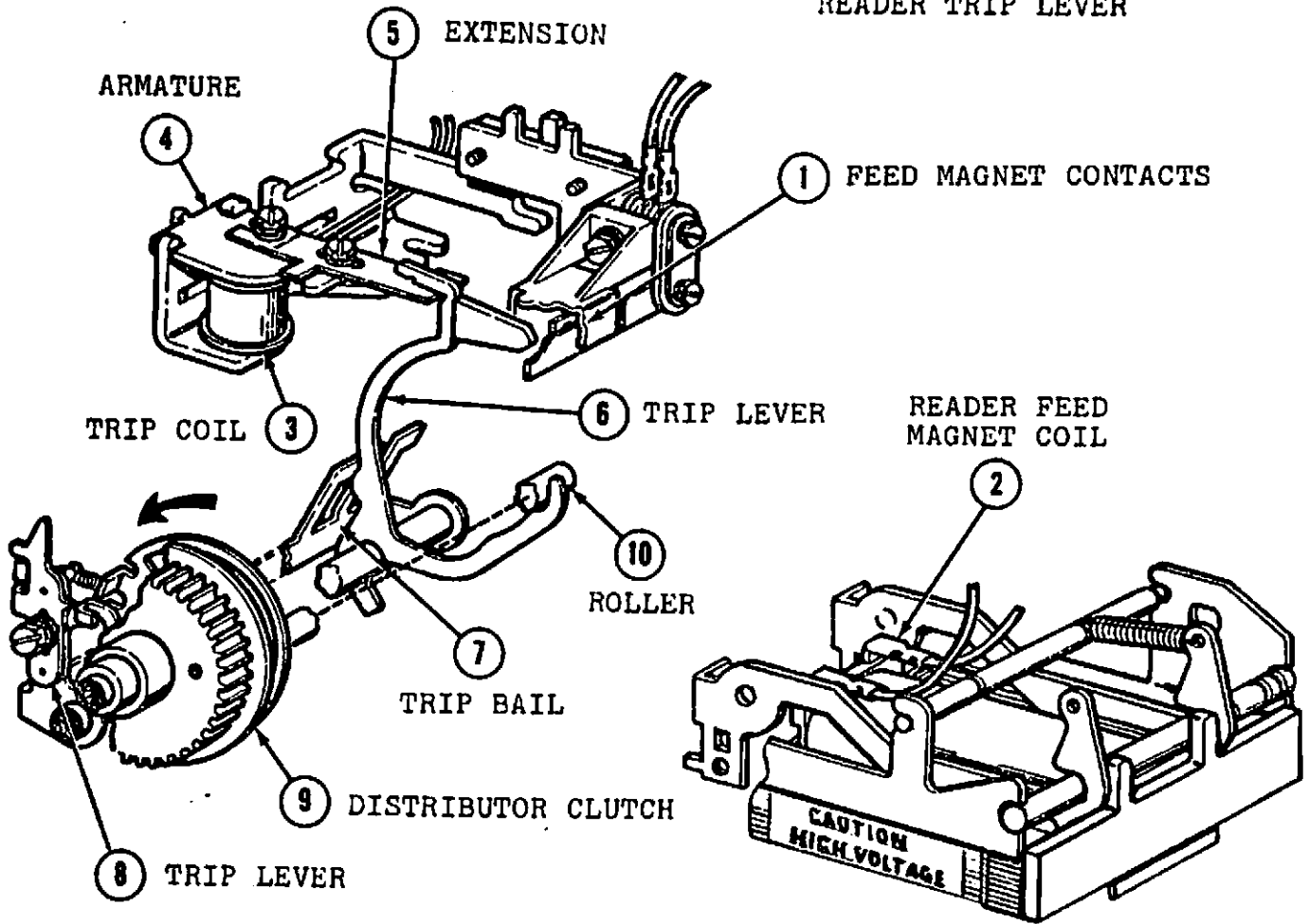

FEED MAGNET CONTACTS (1) are wired in series with READER FEED MAGNET COIL (2) and power source.

TRIP COIL (3) is energized. ARMATURE (4) with EXTENSION (5) is attracted down. READER TRIP LEVER (6) overtravels EXTENSION (5).

FEED MAGNET CONTACTS (1) close and READER FEED MAGNET COIL (2) becomes energized.

Also, READER TRIP LEVER (6) operates TRIP BAIL (7) and attached TRIP LEVER (8) to the rear, engaging DISTRIBUTOR CLUTCH (9).

Sensing and transmission begins.

Late in clutch cycle, a ROLLER (10) cams READER TRIP LEVER (6) forward. FEED MAGNET CONTACTS (1) open and FEED MAGNET COIL (2) de-energizes.

*It's easy finding reasons why other folks should be patient*

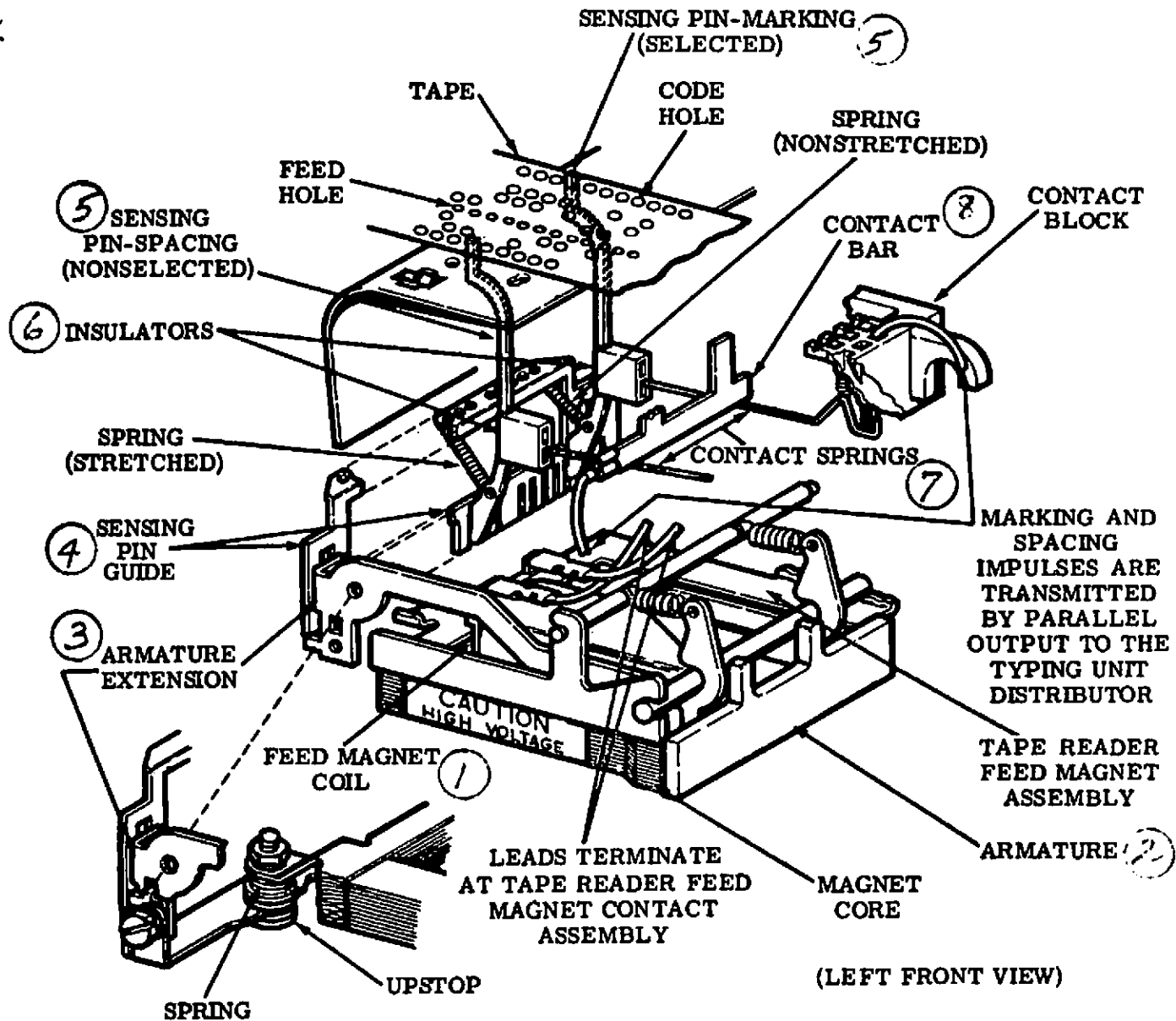

FEED MAGNET COIL (1) energizes attracting ARMATURE (2). ARMATURE EXTENSIONS (3) and attached SENSING PIN GUIDE (4) are raised. SENSING PINS (5) with attached INSOLATORS (6) attempt to follow SENSING PIN GUIDE (4) up.

Where a hole exists in the tape, a sensing pin and attached insulator move up, raising a CONTACT SPRING (7) against the TERMINAL BAR (8) (marking).

Where no hole exists in the tape, the sensing pin is blocked and the CONTACT SPRING (7) remains down (spacing).

All movement is reversed as armature moves to unattracted position. A spring loaded upstop is provided to accelerate the armature release action and also the retraction of sensing pins. A resilient buffer is provided to reduce noise.

*He who throws mud  
loses ground*

## FEED ACTION

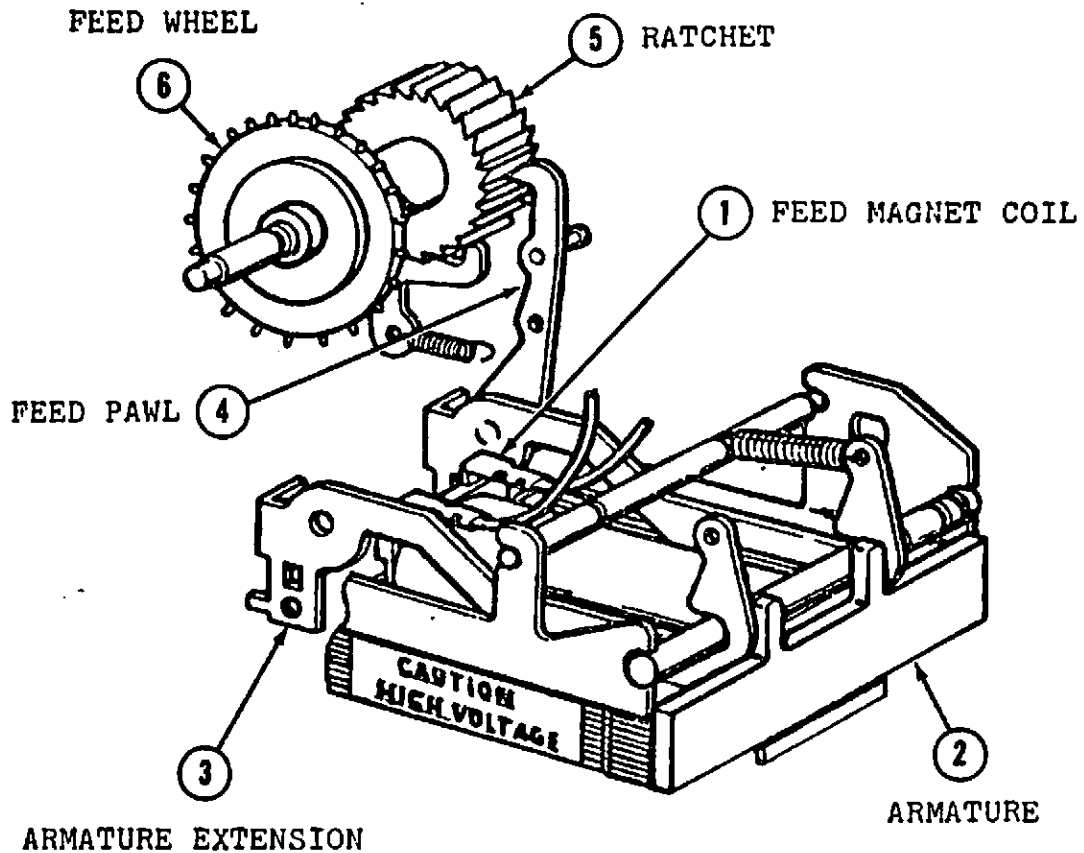

Early in cycle, FEED MAGNET COIL (1) energizes and attracts ARMATURE (2). As ARMATURE EXTENSIONS (3) raise, an attached FEED PAWL (4) moves up to select a new tooth on RATCHET (5). Late in cycle, FEED MAGNET COIL (1) de-energizes, allowing ARMATURE EXTENSIONS (3) to return down. FEED PAWL (4) is pulled down, advancing the RATCHET (5) and FEED WHEEL (6) one unit.

FREE WHEELING

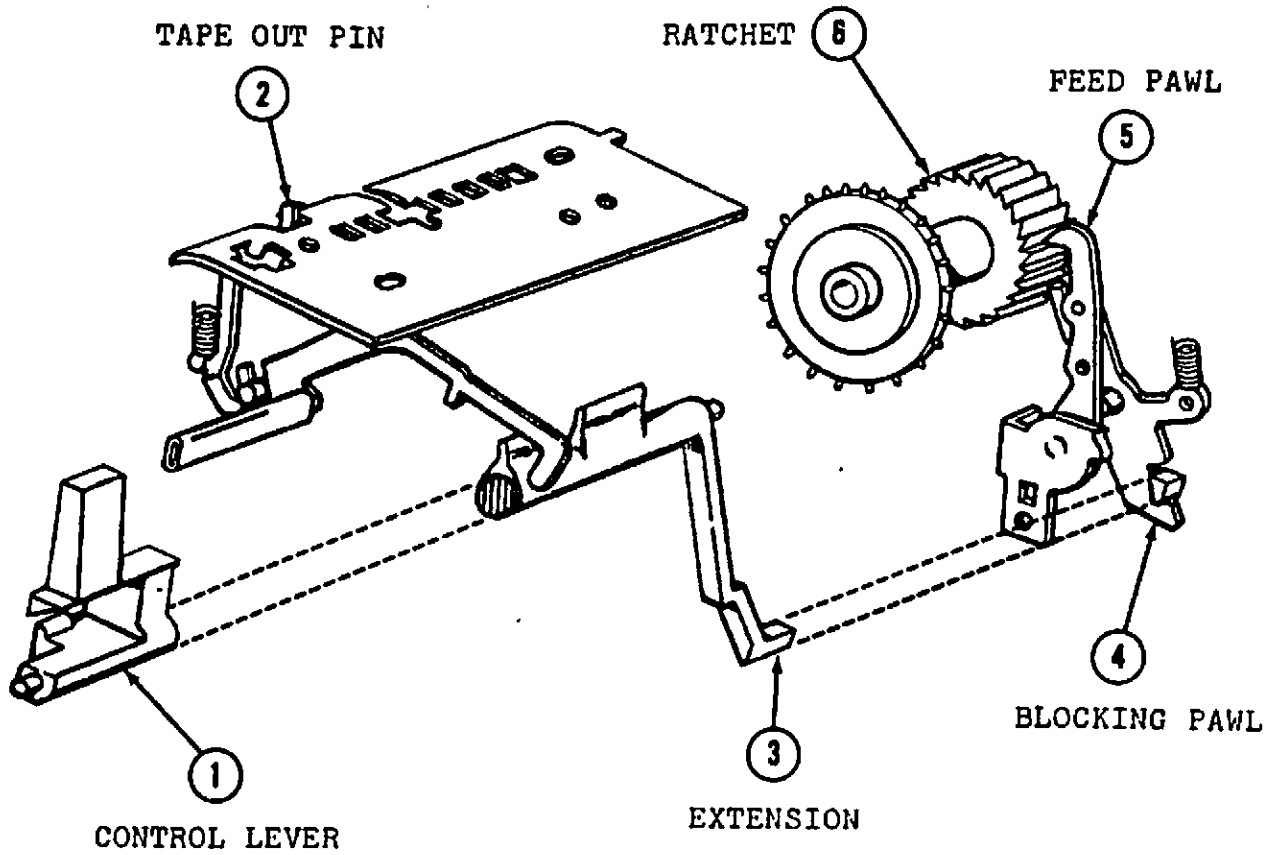

When operating CONTROL LEVER (1) from STOP to FREE, the TAPE OUT PIN (2) is cammed down.

Also, an EXTENSION (3) on CONTROL LEVER (1) engages and rotates BLOCKING PAWL (4) to lift FEED PAWL (5) away from RATCHET (6).

Tape may be repositioned in reader without opening tape lid.

# BASIC READER CIRCUITRY

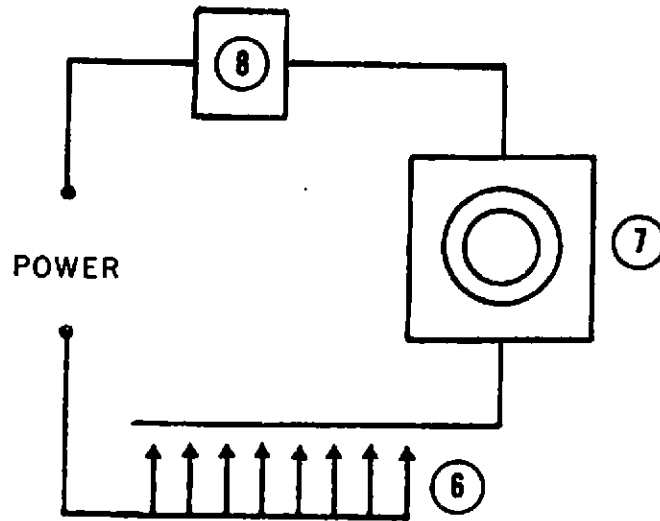

*You will never get a second chance to make a first impression*

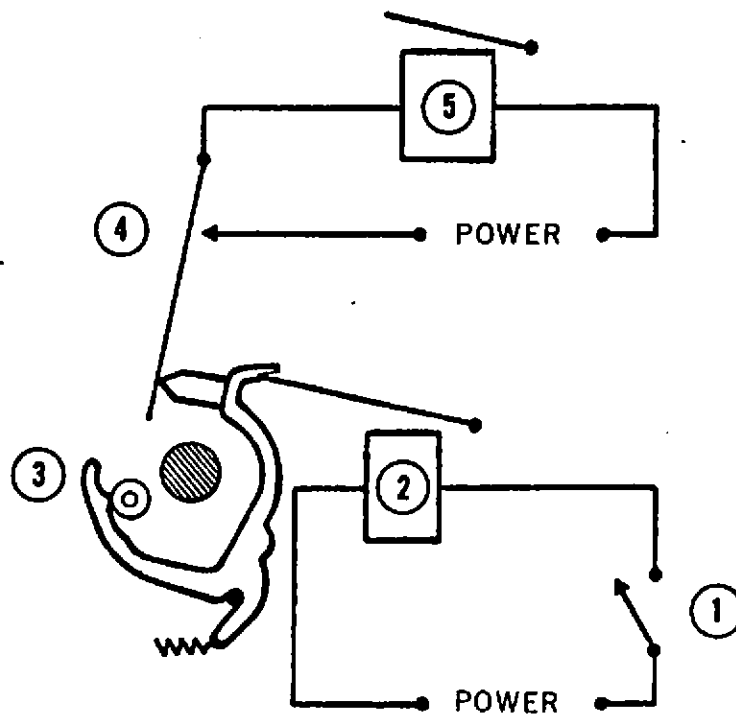

Control CONTACT (1) closes, energizing CLUTCH TRIP COIL (2).  
CLUTCH TRIP LEVER (3) pivots, closing FEED MAGNET CONTACTS (4).  
FEED MAGNET COIL (5) energizes and sensing action occurs.  
READER CONTACTS (6) transmit a parallel output to DISTRIBUTOR (7).  
DISTRIBUTOR (7) transmits serial start-stop signal on line, to  
SELECTOR MAGNET COIL (8).

## MODEL 33 TAPE READER

See the following General System Practices for additional information on the Type 33 Tape Reader:

- A. 574-124-100 -- Principles of Operation
- B. 574-124-700 -- Adjustments
- C. 574-124-701 -- Lubrication
- D. 574-124-701 -- Disassembly and Reassembly
- E. 574-124-800 -- Parts

## 33 CALL CONTROL UNIT

### PRINCIPLES OF OPERATION

The function of a call control unit is to couple a teletypewriter either to telegraph networks or, through a data set, to telephone networks. In some applications, the call control unit provides facilities for initiating, accepting, controlling, and completing calls; while in others, it acts as a connecting device only.

The call control unit used in Western Union TELEX service operates over short and intermediate length telegraph loops using neutral signaling or over longer loops with polar signaling when modified with proper polar-to-neutral converting circuitry. It includes a power supply, local-remote control circuits, a selector magnet driver circuit, and a motor delay timer circuit.

The call control unit is used in switched network service. When it is connected with the appropriate data set, it is connected with conventional telephone central offices having the required routing and message accounting equipment. These are generally the same offices and equipment serving telephone customers in the area. Direct current signals are used for both originating and terminating traffic—providing the same conditions as for conventional local telephone set operation. The dial on the call control unit, for initiation of call connections, may be either a dc pulsing or a multifrequency (MF) tone device. Also included in the call control unit are ringing or tone sounding apparatus for alerting the called party. Paragraphs 3.01 through 3.06 outline in general terms the call control unit's overall operation. Paragraphs 3.08 through 3.32 explain its detailed operation. The principal applicable schematic wiring diagram is 5918WD. For additional wiring information, see the pertinent wiring diagrams, associated with the call control unit or, when provided, the appropriate section.

The call control unit used in private wire service operates over short or intermediate length telegraph loops using neutral dc signaling. It includes a power supply, a selector magnet driver circuit and a power switch.

### CALL CONTROL UNIT—SWITCHED NETWORK SERVICE

#### OPERATION

##### A. General

3.01 The call control unit provides for signaling speeds of 100 wpm from dc marking and spacing intelligence pulses originating from the distributor in the associated teletypewriter. These pulses are directed to the input of the selector magnet driver in the call control unit where they are amplified and returned to the typing unit as 0.500-ampere dc pulses to operate the selector magnet.

3.02 If the originate (ORIG) pushbutton (non-locking) on the call control unit has been depressed and connection with a called station has been satisfactorily completed, the intelligence pulses originated by the distributor are sent to the data set. The data set converts the dc pulses to tone signals for transmission over telephone lines. Another data set, located at the called station, converts the tone signals back to dc pulses, which are directed to the input of the selector magnet driver to operate the selector in the teletypewriter of the called station. The teletypewriter at a given station copies both the transmitted and received dc signals, operating on a half-duplex basis.

3.03 Although the data set is not a part of this equipment, a brief discussion of its function is necessary to understand the operation of the system. Start-stop dc signal pulses form essentially a square wave which cannot readily be transmitted over telephone lines. The data set is basically a converter which changes the dc signals from the sending or calling station into frequency-shifted tones for transmission over the telephone network. A marking pulse from a sending station is converted to a 1270-cycle marking signal (F<sub>1</sub> mark) and a spacing pulse becomes a 1070-cycle spacing signal (F<sub>1</sub> space).

The data set at the receiving or called station sends a 2225-cycle marking signal ( $F_2$  mark) and a 2025-cycle spacing signal ( $F_2$  space). During transmission of a message the calling station sends mark and space tones ( $F_1$  mark and space) while the called station sends a continuous mark tone ( $F_2$  mark). In this way the telephone facilities are operated on a full-duplex basis. If the signal received at either station ( $F_1$  mark and space at the called station and  $F_2$  mark at the calling station) shifts to a space tone for more than one second, or if the received signal is lost for one second, the data set will cause the station to be disconnected. This provides assurance that the connection is maintained for the entire period of message transmission.

3.04 The call control unit used with the data set operates with conventional telephone central offices that have the necessary routing and accounting facilities. In operation, a call is originated by depressing the ORIG pushbutton. A lamp illuminates the pushbutton and the dial tone will be heard through a loudspeaker. If the line is busy, a busy signal will be heard and the clear (CLR) pushbutton (non-locking) should be depressed. If the line is not busy, the operator dials the number of the desired station. This causes the called station to go into connect condition. If the teletypewriter is manually operated, the called station operator presses the answer (ANS) pushbutton (non-locking). Following a short interval, about 1-1/2 seconds, in which telephone facilities are connected, the called station transmits a mark tone ( $F_2$ ) and receives a mark tone ( $F_1$ ) from the calling station. Receiving the continuous  $F_2$  mark tone from the called station for second causes the calling station to go into connect condition, and its motor is turned on. Likewise, the continuous  $F_1$  mark tone from the calling station for 1 second causes the called station to go into connect condition, and its motor is turned on. Either station can now transmit.

3.05 At the end of the message, either station may originate a disconnect by depressing the CLR pushbutton, at which time each station goes back to its idle condition, ready to receive or originate other calls. For keyboard practice, maintenance purposes, or preparation of copy, the local mode (LCL) pushbutton (locking) is depressed. This turns on the motor and disables automatic answering facilities, if present. In the event of an incoming call during local operation, the call control unit responds to ringing signals and the ANS push-

button must be operated manually. Operation of the test (TST) pushbutton (locking) causes received signals to be retransmitted to the test center for maintenance purposes. A lamp, associated with each pushbutton, illuminates the pushbutton whenever that pushbutton has been operated and the operating condition exists. The ANS lamp is pulsed in response to ringing signals of an incoming call, and lights continuously when the call is answered. The CLR lamp is automatically extinguished 1.5 seconds after the pushbutton has been depressed, and disconnect is completed.

3.06 A steady mark signal blinds the associated teletypewriter during all intervals, except when in the connect condition. This prevents spurious characters from being printed except when due to loss of signals, circuit noise, or deliberate break or space-disconnect signals.

#### B. Power Requirements

3.07 Power input to the teletypewriter is 115V  $\pm$ 10 per cent, 60 cps  $\pm$ 2 percent. Average power consumption is 35 watts (not including typing unit motor) with peaks up to 50 watts permitted.

#### PROGRESS OF A CALL

3.08 To originate a call, the ORIG pushbutton is momentarily depressed. This connects the station to the line and lights the ORIG lamp. During the period of time in which connection is being made, the telephone central office makes no time measurements. When the ORIG pushbutton is closed, the call control unit is connected to the telephone line through the data set and an off-hook condition is set up. The amplifier is connected into the circuit so that the dial tone from the central office is heard. The called station is dialed while the amplifier monitors the progress.

3.09 At the called station audible and visible signaling devices are operated. The called station goes off hook and into the connect condition upon operation of the ANS pushbutton circuit, by manual or automatic means, at the distant point. At this time, there is a nonsignaling interval of 1.225 seconds during which accounting and toll recording facilities at the telephone exchange will be cleared. Following the nonsignaling interval, the called station transmits its  $F_2$  mark tone and sets its monitoring timer to respond to the  $F_1$  mark tone

from the calling station. When the continuous  $F_2$  mark tone is received at the calling station for a period of 1 second, indicating that a station has answered, it will go into the connect condition and turn on its motor. When the continuous  $F_1$  mark tone is received at the called station for an interval of 1 second, it will go into the connect condition. The station may now acknowledge the call either by operator keyboarding, or by automatic answer-back message transmission. The monitoring timers at both stations are set to respond to reception of a space tone from the distant station. Traffic can now be exchanged from either station on a half-duplex basis.

### DISCONNECTING A CALL

3.10 During the time the two stations are connected (traffic interval), either station can initiate a disconnect as follows:

(a) A call is normally terminated by the end-of-transmission (EOT) code combination which provides fast disconnect without introducing hit characters. This is accomplished by the data set in response to EOT contact closures in function boxes of both the sending and receiving teletypewriters.

(b) A call connection can also be cleared manually by momentarily depressing the CLR pushbutton. Operation of the CLR pushbutton at either station will cause transmission of a spacing signal of 1.5 seconds duration, after which the station originating the disconnect will discontinue its tone transmission and go back on hook. The other station, after receiving the spacing signal for 1 second, will automatically transmit its 1.5-second spacing signal and then go on hook. Both stations will then be back in their original idle condition in which calls can be either originated or accepted.

### ANSWERING A CALL

#### A. Manual Answering

3.11 To answer a call manually, momentarily depress the ANS pushbutton. This connects the station to the line and lights the ANS lamp. The lamp remains lighted until the answer mode is terminated. Manual answering is necessary only when the automatic answer-back circuit is disabled. The automatic answer-back circuit is disabled by low-paper contacts,

data set relay contacts (when in local mode), and the OUT OF SERV. key.

#### B. Automatic Answering

3.12 Call control units equipped with automatic answering facilities will respond to received ringing signals, turning the teletypewriter on at the end of the ringing interval and proceeding through to the connect condition. Automatic message answer-back is a part of this feature. The presence of an operator is required in order to complete disconnect and return the teletypewriter to idle condition. For unattended service, an automatic disconnect timing device (optional) actuated when a call is answered, will cause the teletypewriter to go through the connect condition, send the 1.5-second spacing tone, and go back on hook if the  $F_1$  mark tone is not received within 8 seconds after the called station answered. This is designed to prevent the unattended station from being made busy by (telephone) calls that fail to cause a full connection to be set up. This feature does not affect normal automatic disconnect upon receiving the 1-second spacing tone or loss of tones due to a dropoff.

### LOCAL MODE

3.13 The local mode (LCL) provides off-line operation of the teletypewriter. The operator selects the local mode by depressing the LCL pushbutton. This lights the LCL lamp and operates the motor control relay (MCR) to energize the motor. The data set connects the sending circuit to the receiving circuit and enables the keyboard and answer-back to transmit. In this condition the teletypewriter can be used for preparing copy, for operator practice, or for maintenance purposes. If an incoming signal is received during this time, ringing signals are received and manual operation of the ANS pushbutton is required in order to receive the message. If the teletypewriter is in a terminal hunting group, the operator must turn the out-of-service (OUT-OF-SERV.) knob to the RESTORE position momentarily and then to NORMAL.

### "OUT-OF-SERV." SWITCH

3.14 The OUT OF SERV. switch prevents the automatic answering of incoming calls. In its NORMAL position (arrow on knob upright), it has no effect or function; in the OUT OF SERV. position (knob rotated counterclockwise and detented) it sets the following conditions:

(a) A contact is closed that causes the OUT OF SERV. lamp to light.

(b) A contact is closed that shorts the ringer coils. This makes the ringer inoperative. As an option the contact can be located to shunt both the ringer and series capacitor (i e, the telephone line). This makes the station appear to be in an off-hook condition or busy to the central office.

(c) A contact is opened that breaks the automatic answer circuit to the answer relay. This prevents the relay from operating in response to the ring-up relay and thus the teletypewriter will not answer.

3.15 For stations that are not in terminal hunting groups, the operator may return the teletypewriter to service by turning the OUT OF SERV. knob to the NORMAL position. For terminal hunting stations, however, the operator must turn the knob to the RESTORE position and hold it until a dial tone is heard. In this position:

(a) A contact is closed that shorts the tip to ring (off-hook condition). This condition is detected by the central office which then releases the teletypewriter from lock-out and applies the dial tone.

(b) A contact is closed that completes a path from the speaker amplifier to ground. This permits the amplifier to pass the line signals (dial tone).

The OUT OF SERV. switch is then restored to NORMAL.

#### LOW-PAPER ALARM

3.16 A low-paper alarm is provided in the teletypewriter. When a low-paper condition occurs, make contacts in the low-paper switch provide ground to the low-paper buzzer, permitting it to operate. Depressing the buzzer-release (BUZ-RLS) pushbutton (locking) in the call control unit silences the buzzer and causes the BUZ-RLS lamp to light. Attempting to release the pushbutton without replenishing the paper supply will result in the buzzer operating. When the paper has been replenished, the teletypewriter is returned to normal by releasing the BUZ-RLS pushbutton.

3.17 Break contacts on the low-paper switch disable the automatic answer-back circuit. The operator can override this condition by answering manually. If the low-paper alarm occurs during a call the operator has the option of completing the call before changing the paper, or interrupting the call. To interrupt the call, the operator stops transmission by depressing the keyboard BREAK key, and then depressing the BRK-RLS pushbutton to notify the distant station of the problem. The connection is cleared by simultaneously operating the control (CTRL) and EOT keys on the keyboard. Turning the OUT OF SERV. knob to the detent position insures that the teletypewriter will not automatically answer a call while paper is being replenished.

3.18 To restore the teletypewriter to service after the paper has been inserted, depress the CLR pushbutton and return the OUT OF SERV. knob to its NORMAL position. (For teletypewriters in terminal hunting groups, turn the knob to its RESTORE position and hold it there. When dial tone is heard, release the knob.) The teletypewriter is now in a normal idle operating position.

#### RESTRAIN LAMP

3.19 This high intensity restrain (REST) lamp lights when a restraining signal is received from an 8-level to a 5-level converter used in transmission to 5-level TWX stations on the DDD switching plan. The lamp remains lighted until the restraining signal is removed. The purpose of this feature is to limit the sending speed from 8-level teletypewriter transmitting at 100 wpm to 5-level teletypewriters receiving at 60 wpm.

#### TEST MODE

3.20 If the TST pushbutton is operated while the teletypewriter is connected to a test center, the message sent by the test center will be recorded on the teletypewriter and turned around and sent back for analysis. This is accomplished by connecting the teletypewriter to the data set through a set of transfer contacts and a break contact to ground. This type of operation can be terminated by momentarily operating any of the nonlocking pushbuttons which will then release the TST locking pushbutton.

## SIGNAL GENERATION

3.31 The teletypewriter can send by operating the keyboard, answer-back mechanism, or BREAK key. The keyboard signal generator contacts and answer-back contacts are in parallel with the signal generator (distributor) which is, in turn, connected to the data set. The BREAK key connects to the data set via separate leads.

## SELECTOR MAGNET DRIVER

### A. General

3.22 The data set supplies a 20-ma dc signal to the selector magnet driver associated with the teletypewriter. The selector magnet driver amplifies the signal to 500 ma to operate the selector on the teletypewriter. The selector magnet driver is a 2-stage transistorized amplifier capable of switching high output currents (0.500 ampere) at very closely controlled input current levels. The output of the selector magnet driver is automatically regulated and is

essentially independent of normal variations in power supply voltage and of selector-magnet and current-limiting resistance values.

### B. Circuit Description

3.23 Figure 13 illustrates a schematic drawing of a selector magnet driver circuit.

3.24 Open Line: When the line circuit is open (spacing), transistor Q1 will be turned on by the regulated current flowing through R1 into its base. This current, which is controlled by R1, will be set near the desired switching level. With Q1 conducting, Q2 will be cut off, since the potential at the base of Q2 will be more positive than at the emitter. In this condition only small leakage currents will flow in the collector circuit.

3.25 Space-to-Mark Transition: As the space-to-mark transition begins, the negative bias current flowing in the base of Q1 is diverted to the line circuit. As the line current rises toward the marking current value, it

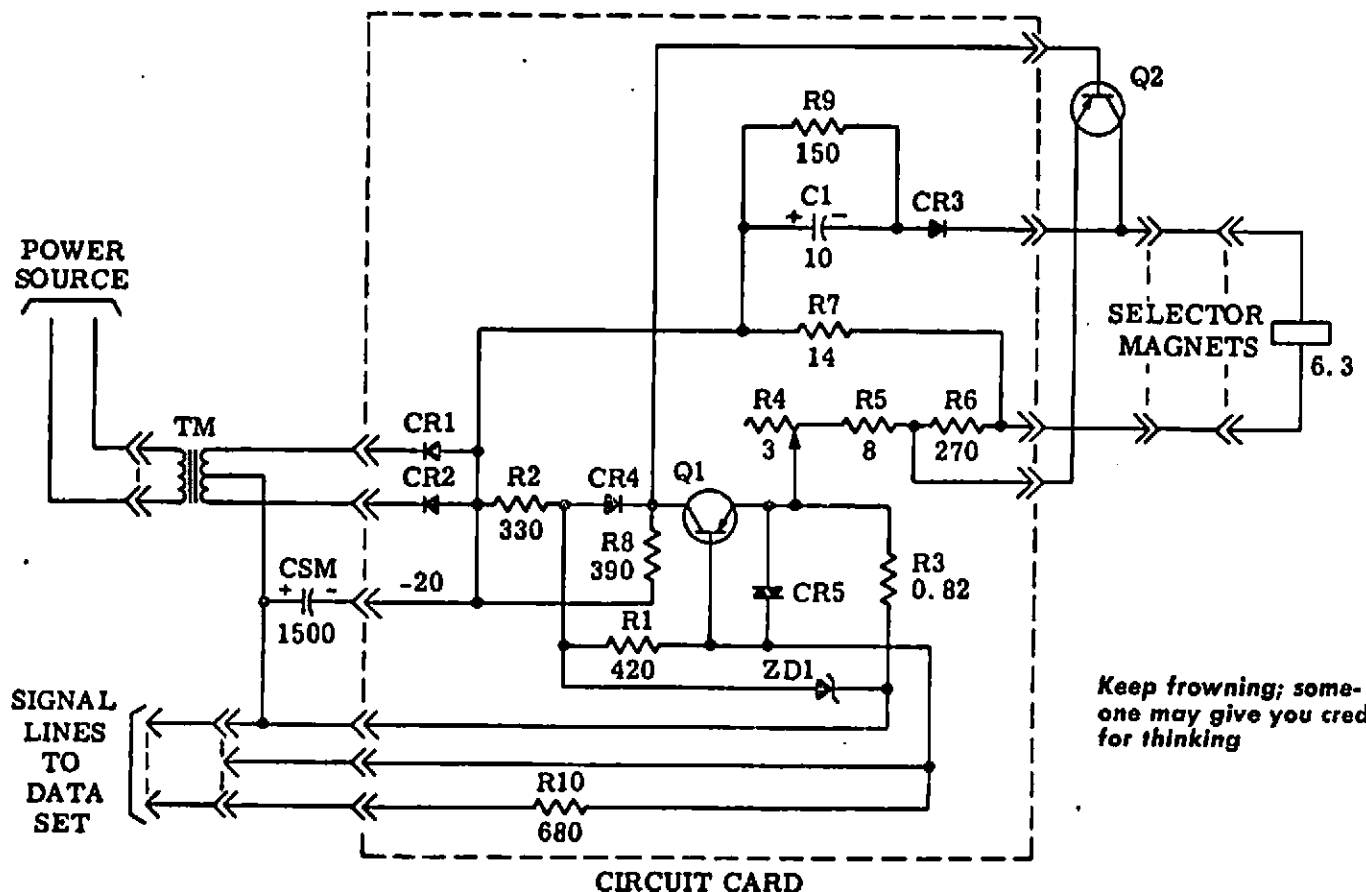

Figure 13 - Selector Magnet Driver Circuit

extracts base current from Q1. When the line current approaches the total current supplied to the base of Q1 to within 0.001 ampere, which is about one-half the nominal mark current value, Q1 begins to turn off. Q2 will then begin to receive forward bias current from R8 and begin to turn on. The base current will then be amplified by Q2, and a current which is a multiple of the base current will appear in the emitter circuit. This increase in emitter current results in an increase in the negative potential measured across R3. The increase in the negative potential at the emitter of Q1 causes it to go further into cutoff. The feedback process continues until the current in the selector magnet reaches a value which is determined by the Zener reference voltage, clamp diode CR4, and the emitter resistance of Q2 (the emitter resistance of Q2 is adjusted by R4 to compensate for component variations. As the line current completes the transition to the final marking current value, the base of Q1 becomes positively biased. The positive bias current will be approximately one-half the total marking line current. The positive potential to the base of Q1 is clamped to approximately 0.6 volt by the input protecting varistor, CR5.

**3.26 Mark-to-Space Transition:** The line current, in changing from mark to space, will finally reach the point where R1 will begin to supply some forward current to the base of Q1. The line current level at which this occurs will be a little more negative than the point at which the circuit switched from space to mark, due to the common emitter resistor voltage feedback. As Q1 begins to turn on, the current through R8 will be diverted from the base of Q2, causing it to begin to turn off. As Q2 turns off, the voltage across R4 will begin to go positive, causing Q1 to be further turned on. This effect gives regeneration to the mark-to-space transition.

**3.27 Mark-to-Space Switching Transient:** When Q2 is turned off during the mark-to-space transition, a negative voltage transient is developed at its collector. This transient is due to dissipation of the energy stored in the magnetic field of the driven magnet when energized by 0.500 ampere. If the high voltage developed at the collector of Q2 were not limited, it would continue to rise until it reaches the point where the collector-to-emitter breakdown voltage is exceeded. It has been found that repeated breakdown of this kind causes deterioration of the transistor and finally a collector-to-

emitter short circuit. Therefore, it is necessary to provide a transient suppressing network at the collector of Q2. The transient-suppression network presently in use is a compromise which affords a minimum peak voltage combined with a magnet release time to provide for adequate teletypewriter margins. The network consists of C1 in parallel with R9. CR3 isolates the network from voltages more positive than negative battery potential.

## SPEAKER AMPLIFIER SYSTEM

**3.28** Figure 14 illustrates a schematic diagram of a speaker amplifier circuit.

**3.29** The speaker amplifier is powered only after the ORIG key is operated and is quieted when the station key connects. It has two inputs, one from the telephone line via the buffer amplifier in the data set limiter and the other from the multifrequency (MF) tone dialer. Three outputs are provided: (1) into the speaker or optional hand-held receiver; (2) into the telephone line through the sending amplifier in the data set; and (3) an auxiliary output into the data set. The line-to-speaker connection permits monitoring of supervisory signals when originating a call. The TOUCH-TONE dial-to-line and TOUCH-TONE dial-to-speaker connection provides for amplification of the outgoing MF dialing signals and for monitoring them during outpulsing. The line-to-second-output connection is provided for the dial tone detector (when furnished). The various connections mentioned are established by switching in the data set and by the common switch in the TOUCH-TONE dialer.

**3.30** The speaker amplifier is a conventional direct-coupled, 2-transistor audio amplifier. The input signals from the telephone line are fed through the receiving buffer amplifier in the data set into the primary winding of the input transformer (T1). The primary winding continually carries approximately 4 ma quiescent current from the receiving buffer amplifier. The other input, from the TOUCH-TONE dialer is fed directly into Q1 through C5. Both inputs are dc isolated from the amplifier stages.

**3.31** Two outputs are taken from transistor Q2, one from the collector circuit and the other from the emitter.

(a) The collector output is fed through a step-down output transformer (T2) into

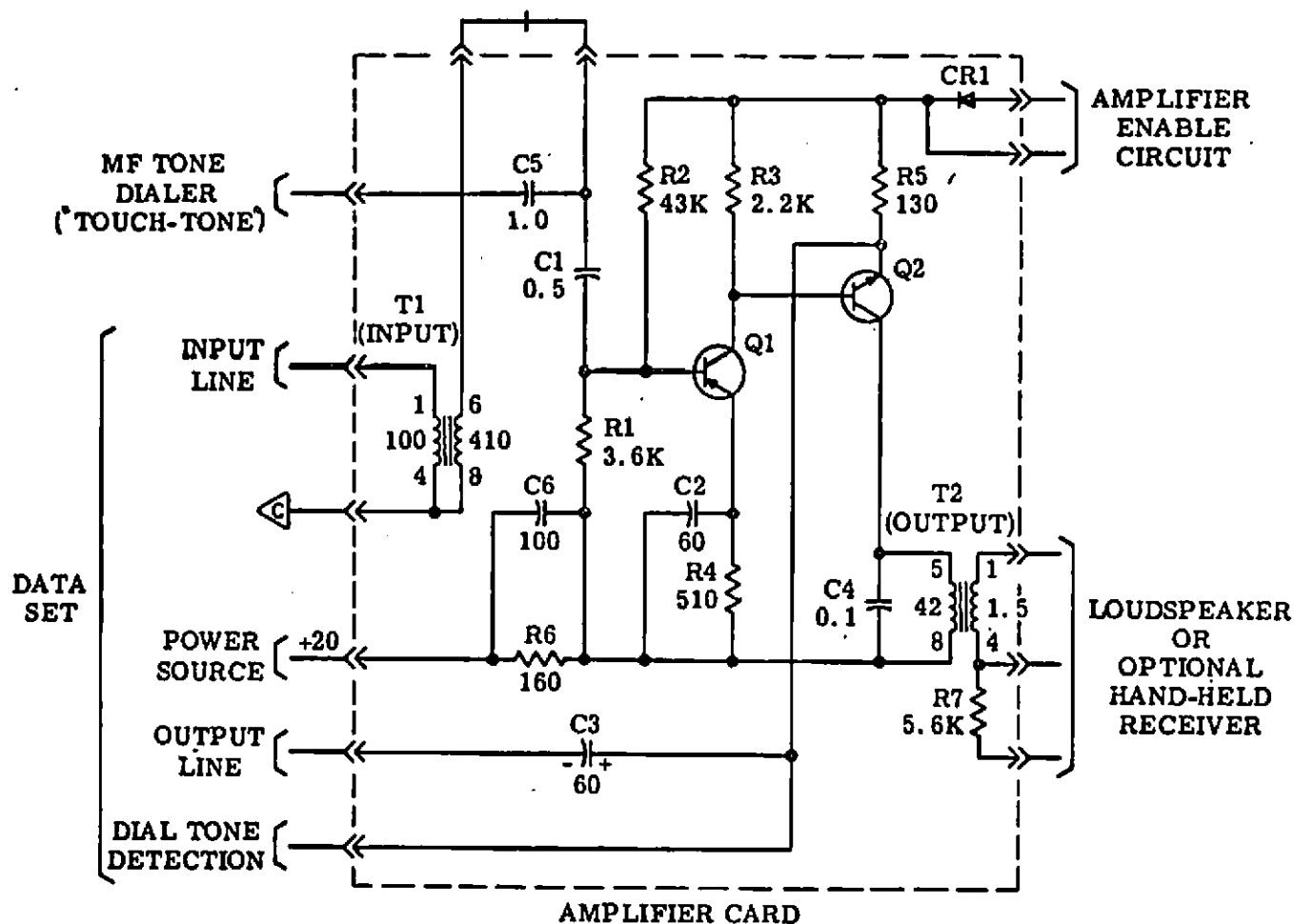

Figure 14 - Speaker Amplifier Circuit

the speaker (or receiver). A potentiometer is used to set proper volume for varying loop loss and ambient noise level. The TOUCH-TONE dialer signals are independent of loop loss.

(b) The emitter output splits into two signal lines: one for injecting the MF dial tones into the data set sending amplifier, and the other for feeding the dial-tone detection circuit (when provided). The signal level from the emitter output is essentially independent from the setting of the potentiometer.

3.32 Bypassed R6 is a supply voltage dropping resistor. Diode CR1 is provided to block a sneak path (in the answer mode) from ground through the ANS and ORIG lamps. Without the CR1, the ORIG lamp would be dimly lit and the amplifier would not be silent when the station is in the answer mode. The amplifier operates only in the originate mode until the station connects. In any mode other than originate, the ground is disconnected. When the

station connects, the amplifier input is short-circuited in the dial set.

## DIALER MECHANISMS

### A. Pulsing Rotary Dialer

3.33 For rotary dialer applications, a pulsing contact of the rotary dialer is inserted into the telephone line. The manual rotary dialer is equipped with a normally closed pulsing contact and a normally opened off-normal contact. The pulsing contact is inserted into the telephone line when the station originates a call. When answering, a short circuit is applied across the pulsing contact. The off-normal contact is placed across the output of the amplifier and silences the speaker whenever the dialing disc is moved.

*Only people who do things get criticized*

*Some men are  
"blisters"—they show  
up after the job is done*

### CALL CONTROL UNIT—PRIVATE WIRE SERVICE

#### OPERATION

4.01 Power for the motor, selector magnet driver, local power supply, and tape reader power pack, when provided, is supplied from fused 115-volt ac, 60 cps power. Direct current of either 0.020 or 0.060 ampere is required for the signal line(s) and for operation in the local mode. Battery for the signal line(s) is supplied by the customer's facilities, while local battery for operation in the local mode is furnished through the operation of the local power supply circuit in the call control unit. At the rear of the call control unit is a terminal strip which provides the point of entry for the ac power and the signal line(s) into the teletypewriter.

4.02 The purpose of the selector magnet driver is to amplify received dc marking and spacing intelligence pulses. Received dc intelligence pulses are directed to the input of the selector magnet driver circuit in the call control unit where they are amplified and returned as 0.500-ampere dc intelligence pulses to operate the typing unit selector. A detailed description of the operation of a selector magnet driver is given in 3.22 through 3.27. The selector magnet driver described there is similar to the ones used in private wire service.

4.03 A 3-position rotary power switch is the only manual control on the call control unit. Its purpose is threefold: Through the operation of the rotary power switch, the teletypewriter can be (1) placed in the external signal line loop for communication with other teletypewriters, (2) removed from the external signal line loop for local operation, or (3) placed in the off condition.

#### POWER SWITCH

4.04 Figure 17 is a schematic drawing of the rotary power switch and local power supply circuits. The following chart indicates the condition of the rotary power switch contacts - either open or closed - when the control knob is turned to one of its positions:

Knob Position	Line Segment		Contacts Condition
	From	To	
LINE	L1	2	Closed
	L1	1	Closed
	L2	2	Open
LOCAL	L1	2	Closed
	L1	1	Open
	L2	2	Closed
OFF	—	—	All Open

4.05 With the rotary power switch in the off mode—the control knob is in the OFF position—the signal line is diverted around the local teletypewriter, and other teletypewriters in the external signal line loop can communicate without interference. All power in the call control unit, except the ac power to the selector magnet driver, is off.

4.06 When the rotary power switch is placed in the local mode—the control knob turned to the LOCAL position—the line relay is not energized. The normally closed contacts A remain closed, and the normally open contacts B remain open. In this condition the circuit is such that (1) local battery is supplied to the selector magnet driver and the send circuit, (2) the external signal line loop is divorced from the selector magnet driver, and (3) the external signal line loop is shunted so that other teletypewriters in that loop can communicate without being affected by the operation of the local teletypewriter.

4.07 If the rotary power switch is placed in the line mode—the control knob turned to the LINE position—the line relay is energized. This causes the normally closed contacts A to open and the normally open contacts B to close. Thus, the normally closed contacts A and the normally open contacts B are conditioned such that (1) the external signal line loop is united with the selector magnet driver, and (2) the local teletypewriter is placed in the external signal line loop, so that it can communicate with

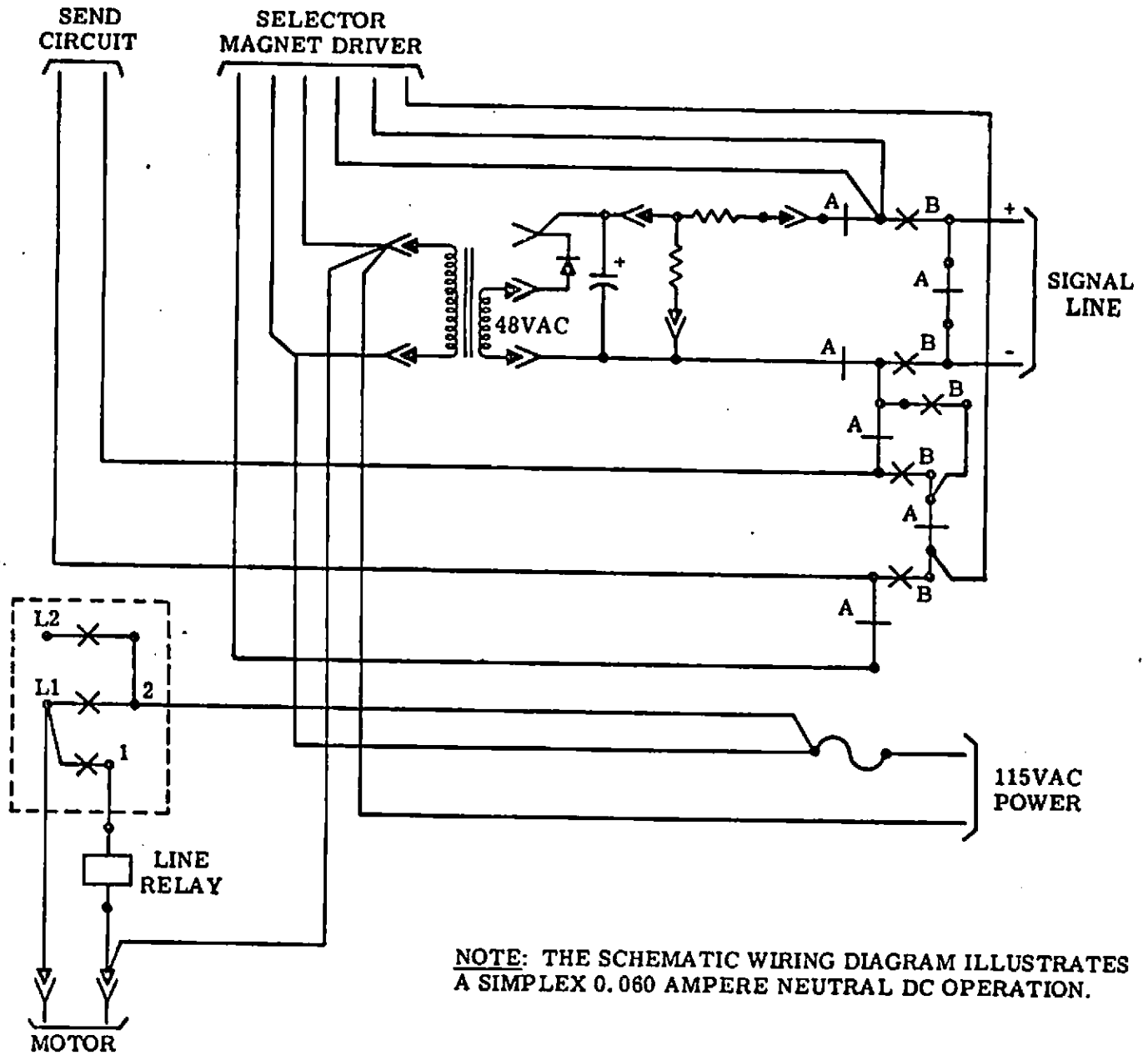

NOTE: THE SCHEMATIC WIRING DIAGRAM ILLUSTRATES A SIMPLEX 0.060 AMPERE NEUTRAL DC OPERATION.

Figure 17 - Rotary Power Switch and Local Power Supply Circuit

*Some people are  
magnetic—everything  
they own is charged*

other teletypewriters in that loop. With battery on the signal line, any transmission from the keyboard or tape reader, when provided, will cause the typing unit distributor to send start-stop signals to other teletypewriters in the

external signal loop. Also, the local teletypewriter is able to receive, through the typing unit selector, the start-stop signals transmitted from other teletypewriters in the external signal line loop.

## CALL CONTROL

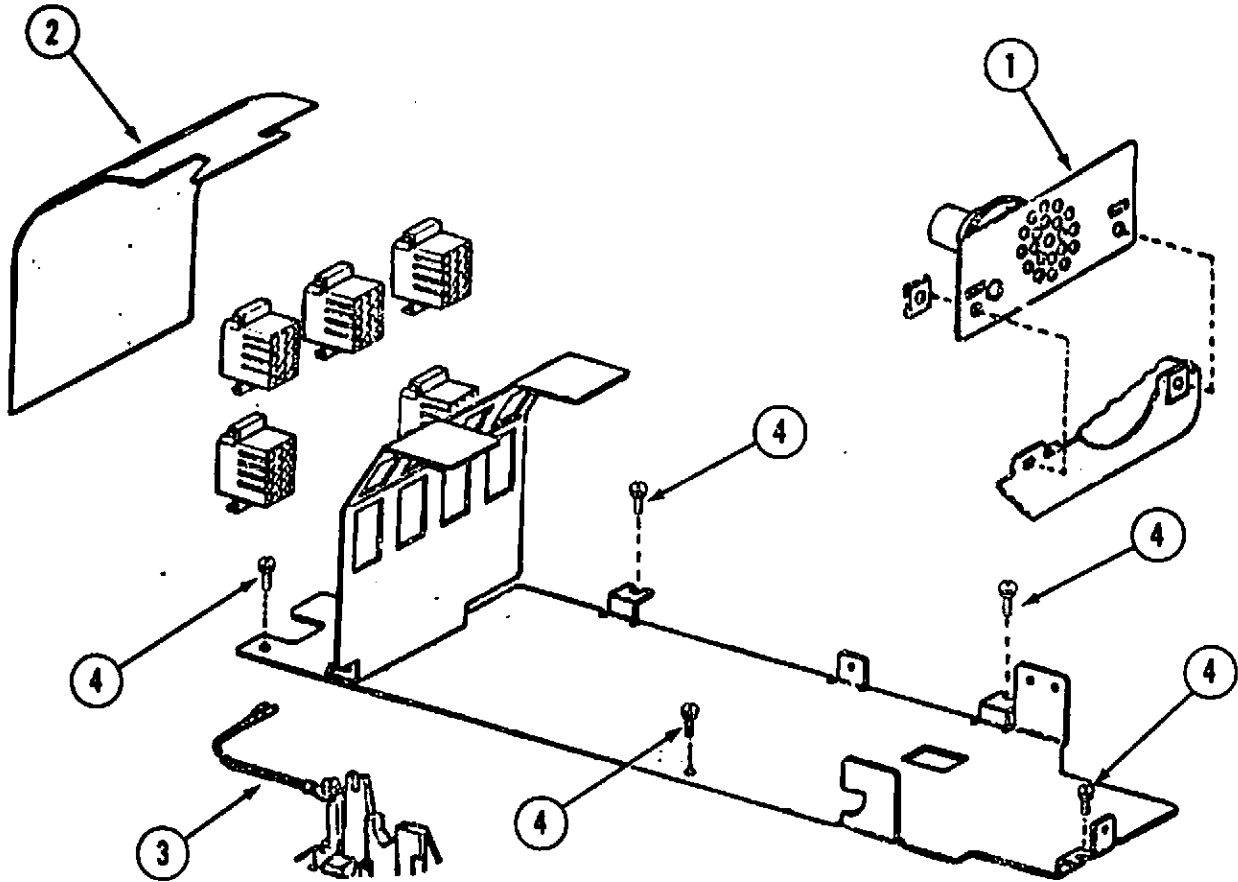

- ① Remove speaker, if present, from front of call control unit with both speed nuts by pulling upward.
- ② Remove insulator from rear of call control unit. Disconnect all nylon plugs.
- ③ Remove ground strap from terminal on call control unit.
- ④ Remove four (4) call control mounting screws. Lift call control unit out of sub-base. Some units may have a fifth mounting screw.

SUPPORTING INFORMATION		CONTENTS	SHT. NO.	NOTES
DESCRIPTION	REFERENCE			
Technical Manual: 32 & 33 TTY's	TTY Bulletin 273B	FS-1 TEST FS-2 BREAK RELEASE FS-3 RESTRAIN FS-4 CLEAR FS-5 ANSWER FS-6 ORIGINATE FS-12 EOT DISCONNECT	2	1. Voltages are DC unless otherwise specified. 2. Terminals designations enclosed in parentheses are for reference and are not marked on component. 3. Resistance values are in ohms unless otherwise specified. 4. Capacitance values are in microfarads unless otherwise specified.
DATA SET	AE101C GSP 555-412-100 GSP 555-412-200 GSP 555-412-300	FS-7 ROTARY DIAL AND PULSING CARD DIALER FS-8 AMPLIFIER	3,4	5. $\rightarrow$ Indicates female and $\rightarrow$ Indicates male terminal on connector. 6. $\bigcirc$ Indicates "j" terminal block in data set.
DIALER	8G 25F1 26C 41A	FS-9 TOUCH TONE DIALER AND AMPLIFIER CIRCUIT FS-10 SIGNAL GENERATORS AND SMD	5,6	7. $\downarrow$ Indicates common return to the power supply-not related to chassis potential. 8. $\square$ Denotes ARC suppression network L53631. 470 $\square$ $\square$ $\square$
RELATED TELETYPE CORP. DRGS.	NO.	FS-11 LOCAL, READER CONTROL, MOTOR CONTROL, AND ANSWER BACK CIRCUITS FS-13 OUT OF SERVICE FS-14 RINGER CIRCUIT AND OFF HOOK CIRCUIT FS-15 PAPER ALARM FS-17 PRINT-NONPRINT OPTION FS-16 POWER CIRCUITS	7 8 9 10 11	9. Data Set strapping options: $\textcircled{S}$ - DC Long Line $\textcircled{L}$ - Not Long Line $\textcircled{X}$ - Half Duplex $\textcircled{Z}$ - Auto Answer 10. CN Conn. = P Conn. CP Conn. = T Conn. 11. Rly spring no's. in ( ) are AE101CX
(182695 Selector Magnet Driver) (18300, 801, 802, 803 Printer) (18300, 804 Keyboard) (181870 And 182241 Motors) (18300, 801 Reader) (UC3 Call Control Unit) Circuit Card Assembly (SMD) Circuit Card Assembly (Amplifier) Circuit Card Assembly (Automatic Reader Power Pack) Circuit Card Assembly (Manual Reader Power Pack) (183087, 7111WD) (183087, 7111WD) (183087, 7111WD)	4970WD 7884WD 7885WD 7886WD 7887WD 7888WD 182630 182750 183079 183087 7111WD 7112WD	SC-1 AUTOMATIC ANSWER BACK SC-2 HERE IS OR WRU ANSWER BACK SC-3 MOTOR CONTROL SC-4 AUTOMATIC READER CONTROL (ASR ONLY)	12	
MODELS INCLUDED		33C1 THROUGH G5 33C-X3/1 THROUGH/5 33F1 THROUGH/5 33F-X3/1 THROUGH/5 33C1 THROUGH G5 33TAE1 THROUGH TAE5 33TR, 33TR2 33TW-1 THROUGH-5		

PER TELETYPE DRG 7882WD, ISSUE 4, 6-10-66.

DESIGNED BY H. C. Telcott	CHECKED BY	SCALE	DATE 9-1-67	SIZE B
APPROVED <i>HCT</i> 2-7-68				
SCHEMATIC WIRING DIAGRAM FOR MODEL 33 ASR & KSR TTY WITH AE101C DATA SET FAMILY				DRAWING NO. 49-B-0869-1
DRAWING NO. 49-B-0869-1				SHEET 1 OF 12
SHEET 1 OF 12				APP'D.
ISSUE				APP'D.
It's easier to take the day off than to put it back				

CONVENTIONAL COPY FOR PUBLICATION  
THIS DRAWING IS THE PROPERTY OF THE AUTOMATIC ELECTRIC LABORATORIES, INC. AND IS LOANED TO YOU FOR YOUR INFORMATION ONLY. IT IS NOT TO BE REPRODUCED OR TRANSMITTED IN ANY FORM OR BY ANY MEANS, ELECTRONIC OR MECHANICAL, INCLUDING PHOTOCOPYING, RECORDING, OR BY ANY INFORMATION STORAGE AND RETRIEVAL SYSTEM. AUTOMATIC ELECTRIC LABORATORIES, INC. IS NOT RESPONSIBLE FOR ANY DAMAGE TO OR LOSS OF ORIGINAL OR COPY OF THIS DRAWING.

AUTOMATIC ELECTRIC LABORATORIES, INC.  
NORTHLAKE, ILLINOIS, U.S.A.

FOR PLANT TRAINING INFORMATION ONLY



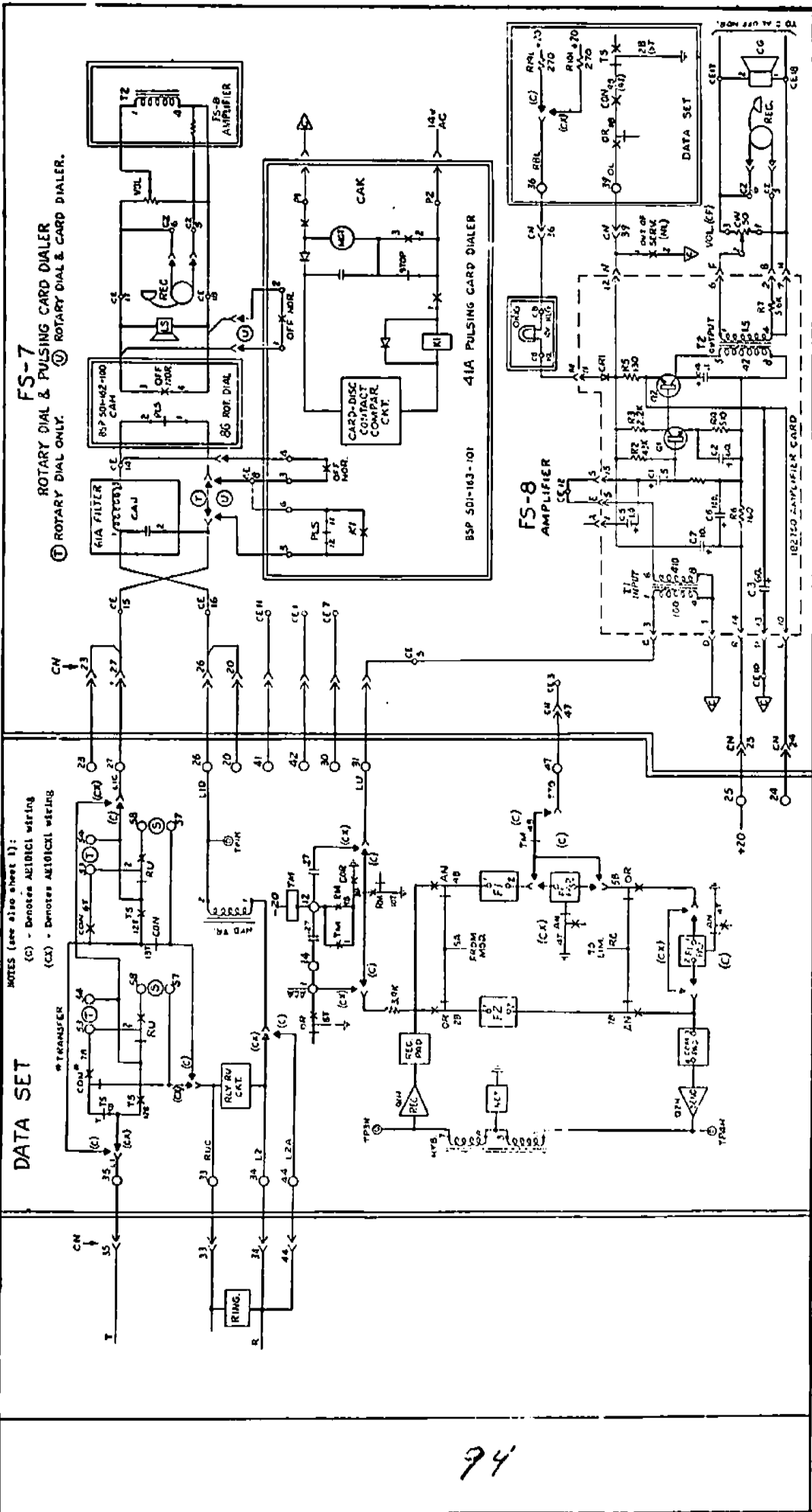

NOTES (see also sheet 1):  
 (C) - Denotes AERDICI wiring  
 (CX) - Denotes AERDICI wiring

**SCHEMATIC WIRING DIAGRAM FOR MODEL 33 ASR & MSR TTY AERDICI DATA SET FAMILY**

49-B-0869-1-C

REVISION 3 OF 12

AUTOMATIC ELECTRIC LABORATORIES, INC. NORTHPLATE, MASSACHUSETTS U.S.A.

DATE: 2-7-60

BY: H. C. TALCOTT

APPROVED: H. C. TALCOTT

REVISIONS:

NO.	DESCRIPTION	DATE
1	71 Input	2-7-60
2	72 Input	2-7-60
3	73 Input	2-7-60
4	74 Input	2-7-60
5	75 Input	2-7-60
6	76 Input	2-7-60
7	77 Input	2-7-60
8	78 Input	2-7-60
9	79 Input	2-7-60
10	80 Input	2-7-60

**There is always a premium on the ability to get things done**

FOR PLANT TRAINING INFORMATION ONLY

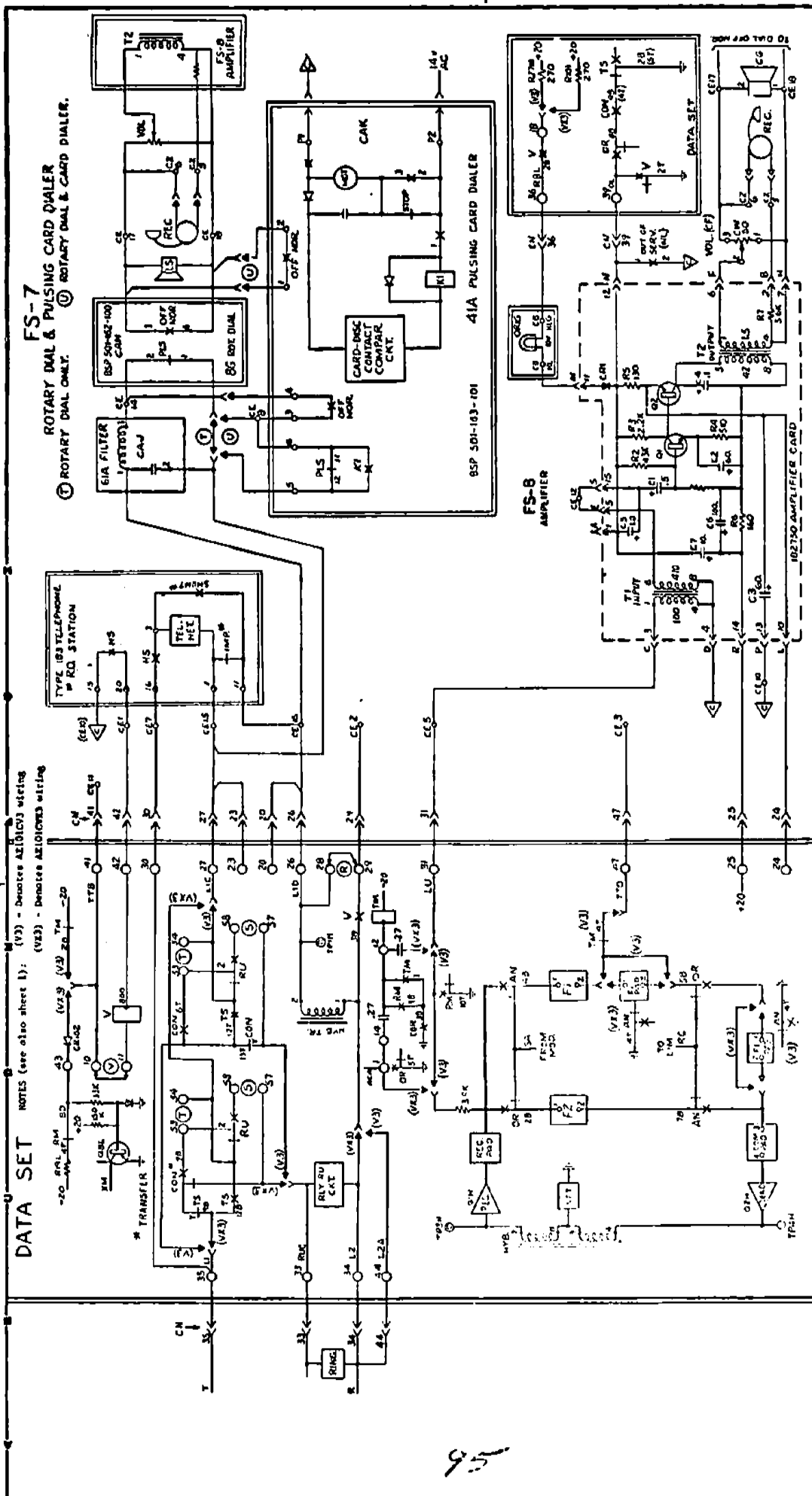

SCHEMATIC WIRING DIAGRAM FOR MODEL 33 AIR & SER TTY AZIOTHIC DATA SET FAMILY → AE101CV3 & AE101CV3	
R. C. Telecote <i>HCF</i>	2-2-68
49-B-0869-1	B
AUTOMATIC TELETYPE LABORATORIES, INC. NORTH PLAINFIELD, NEW JERSEY, U.S.A.	

95

**FS-9**

**TOUCH-TONE DIALER & AMPLIFIER**

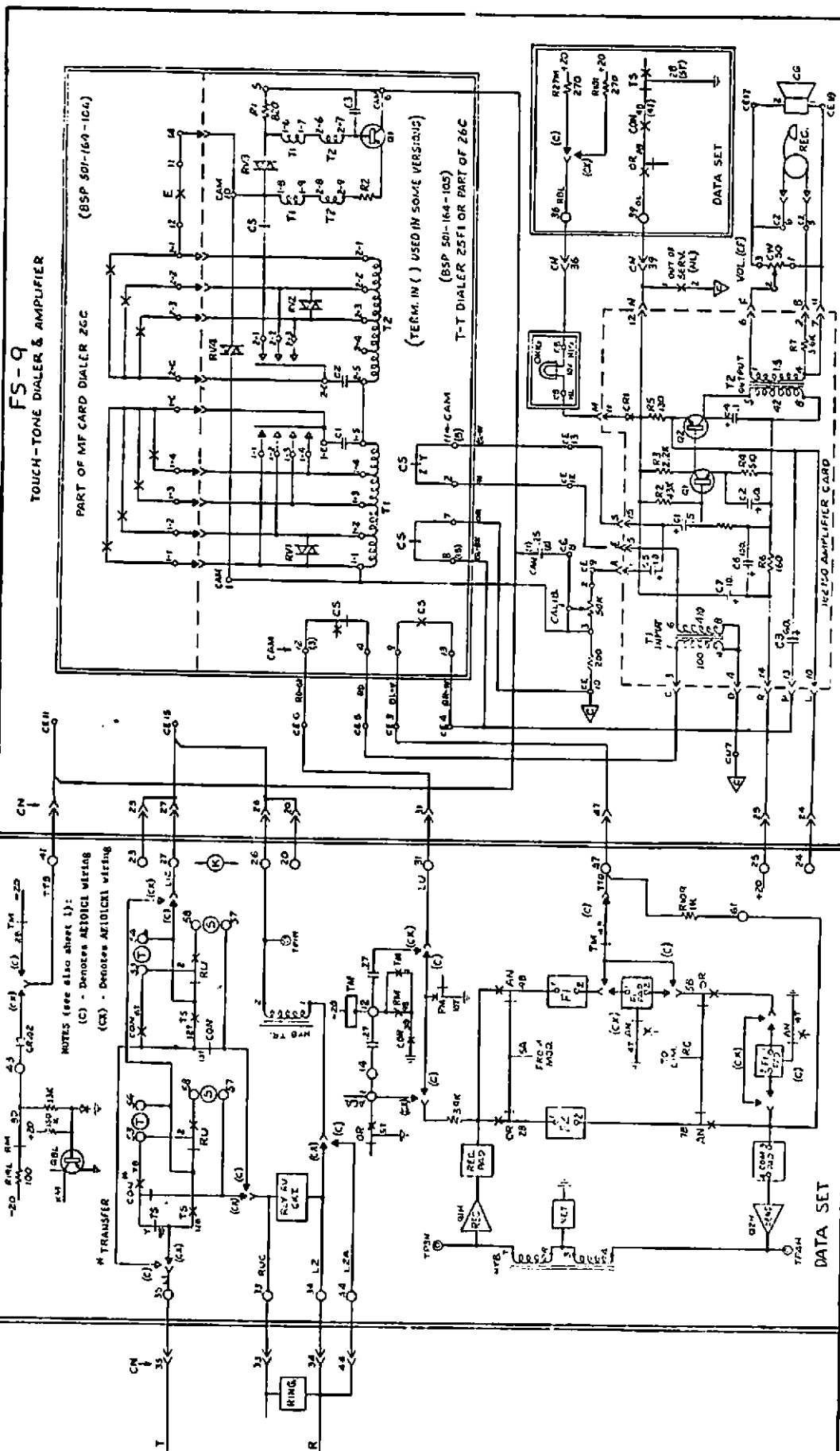

(TERM. IN ( ) USED IN SOME VERSIONS)

(BSP 501-164-104)

(BSP 501-164-105)

(BSP 501-164-104)

(BSP 501-164-105)

(BSP 501-164-104)

(BSP 501-164-105)

(BSP 501-164-104)

(BSP 501-164-105)

(BSP 501-164-104)

(BSP 501-164-105)

(BSP 501-164-104)

(BSP 501-164-105)

(BSP 501-164-104)

(BSP 501-164-105)

(BSP 501-164-104)

(BSP 501-164-105)

(BSP 501-164-104)

(BSP 501-164-105)

(BSP 501-164-104)

(BSP 501-164-105)

**SCHEMATIC WIRING DIAGRAM**  
**MODEL 33 ASB & ASB TTY**  
**WITH**  
**ALDICE DATA SET FAMILY**  
**ALDICE & ALDICEI**

**49-B-0869-1**

**REV. 5 OF 12**

**DATE** 2-2-68

**BY** H. C. TALDICE

**CHKD BY** H. C. TALDICE

**APP'D BY** H. C. TALDICE

**REVISIONS**

NO.	DESCRIPTION	DATE
1	...	...
2	...	...
3	...	...
4	...	...
5	...	...

**APPROVED FOR RELEASE**

**FORM 100-1**

**U.S. GOVERNMENT PRINTING OFFICE: 1967 O 308-100**

**Any fool can criticize, condemn and complain --and generally does**

**FOR PLANT TRAINING INFORMATION ONLY**

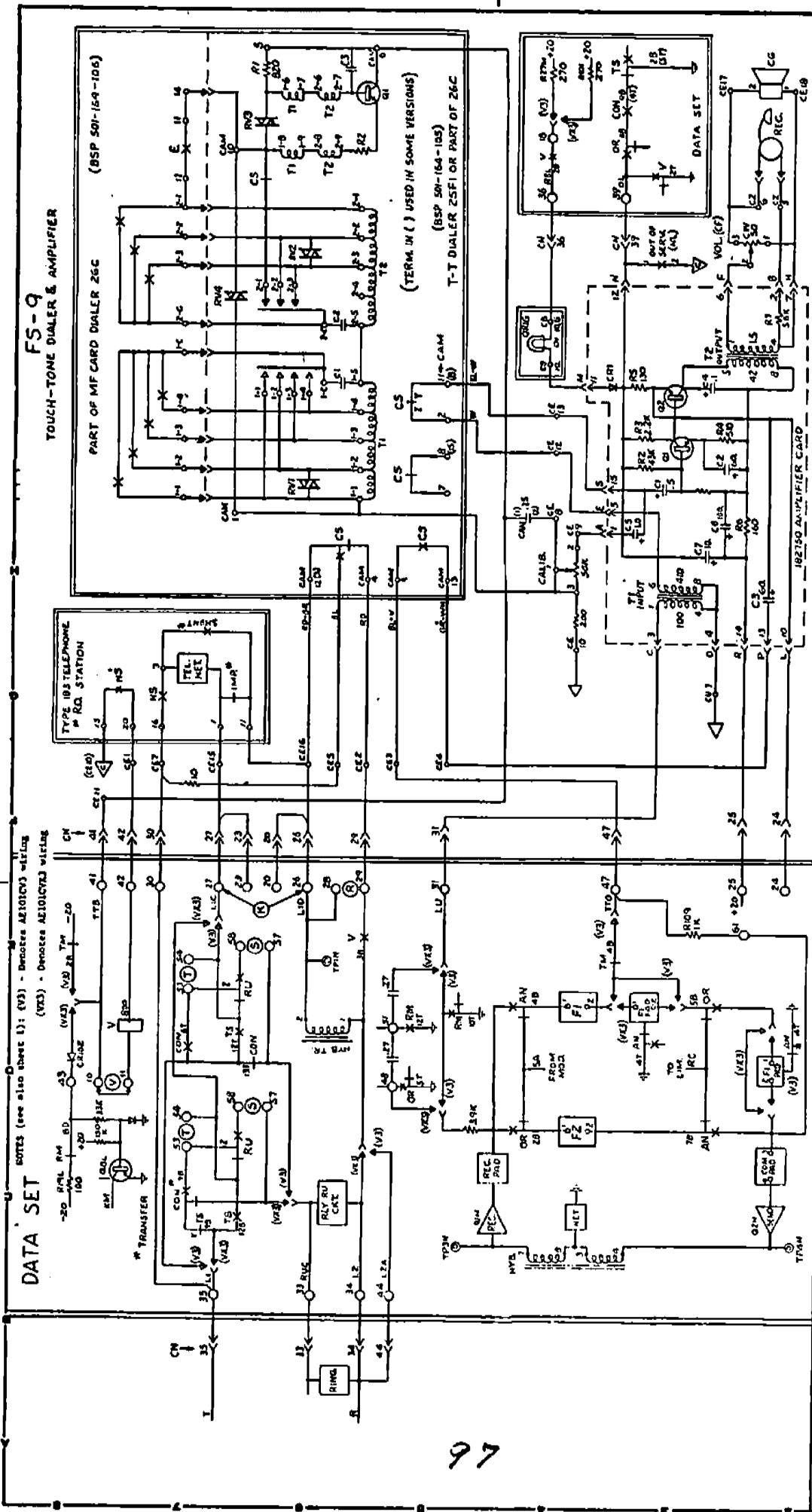

**FS-9**  
TOUCH-TONE DIALER & AMPLIFIER

NOTES (see also sheet 1): (V3) - Demotes A21010V3 wiring  
(V2) - Demotes A21010V2 wiring

SCHEMATIC WIRING DIAGRAM FOR MODEL 33 ASB & KSB TTY WITH A21010 DATA SET FAMILY	
H. C. Telecort	DATE: 2-2-68
49-B-0869-1	REV: B
AUTOMATIC ELECTRIC LABORATORIES, INC. ANN ARBOR, MICHIGAN, U. S. A.	

# FS-10 SIGNAL GENERATORS AND SELECTOR MAGNET DRIVER

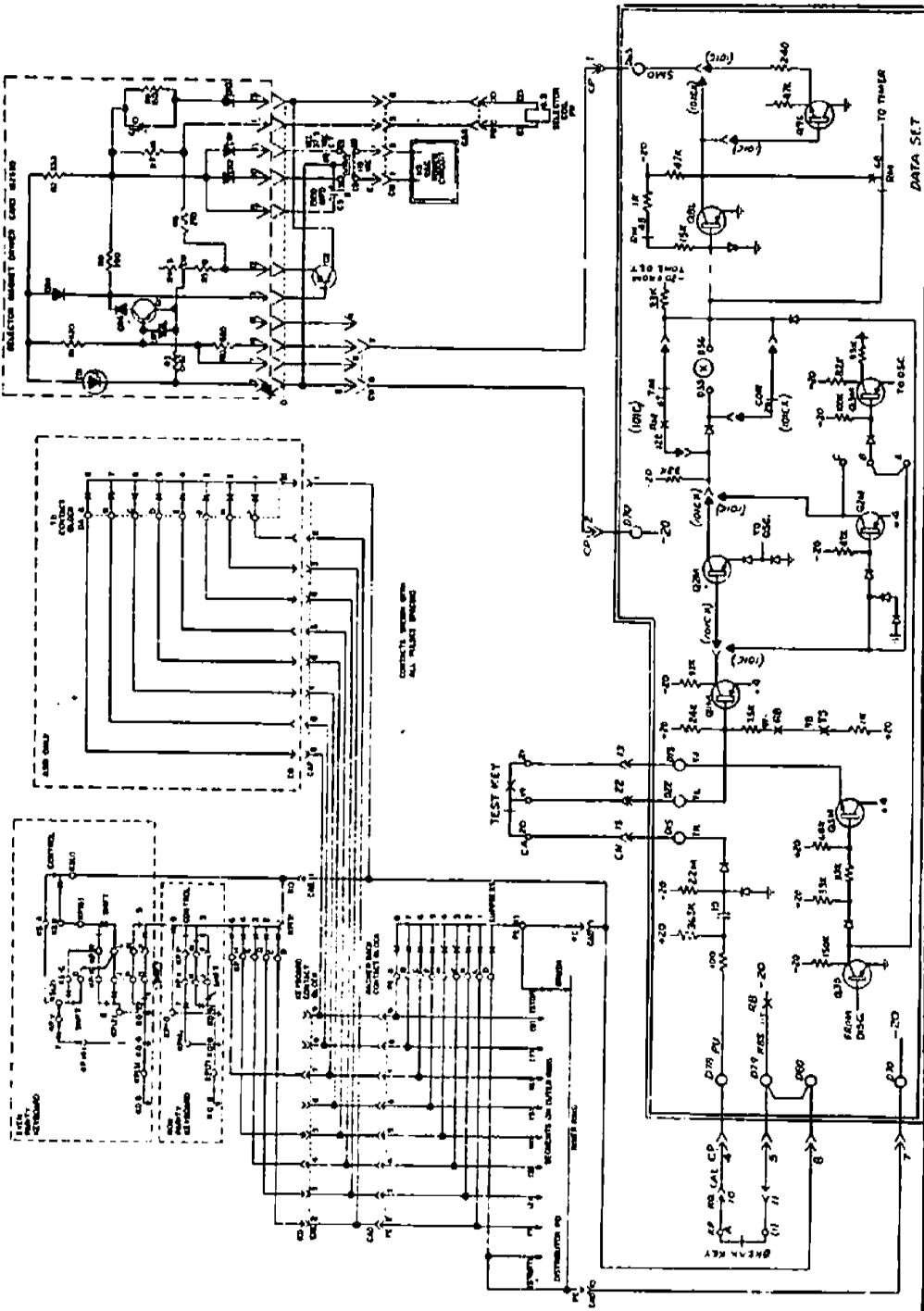

See sheet 1  
for notes

SCHEMATIC WIRING DIAGRAM	
MODEL 33 ASR & ESR TTY WITH AERIOIC DATA SET FAMILY	
DRAWN BY CHECKED BY APPROVED BY DATE 9-1-67	SHEET 7 OF 12 49-B-0869-1-C AUTOMATIC ELECTRIC LABORATORIES, INC. WASHINGTON, D.C. 20546

FOR PLANT TRAINING INFORMATION ONLY



NOTES (see also sheet 1):

- (C) - Denotes AE101C1 & AE101C3 wiring
- (CX) - Denotes AE101C1 & AE101C3 wiring
- (V/D) - Denotes VOICE/DATA wiring for AE101C3 & AE101C3
- (R) - T-T Dial wiring for DATA only; AE101C1 & AE101C3
- (S) - Strap for Rotary Dial with VOICE/DATA wiring; AE101C3 & AE101C3
- (D) - Strap for T-T Dial with VOICE/DATA wiring; AE101C3 & AE101C3
- (V) - Strap for VOICE/DATA service with VOICE/DATA wiring; AE101C3 & AE101C3
- (V) - Strap for DATA-only service.

FS-13  
OUT OF SERVICE

Even a stopped clock  
is right twice a day

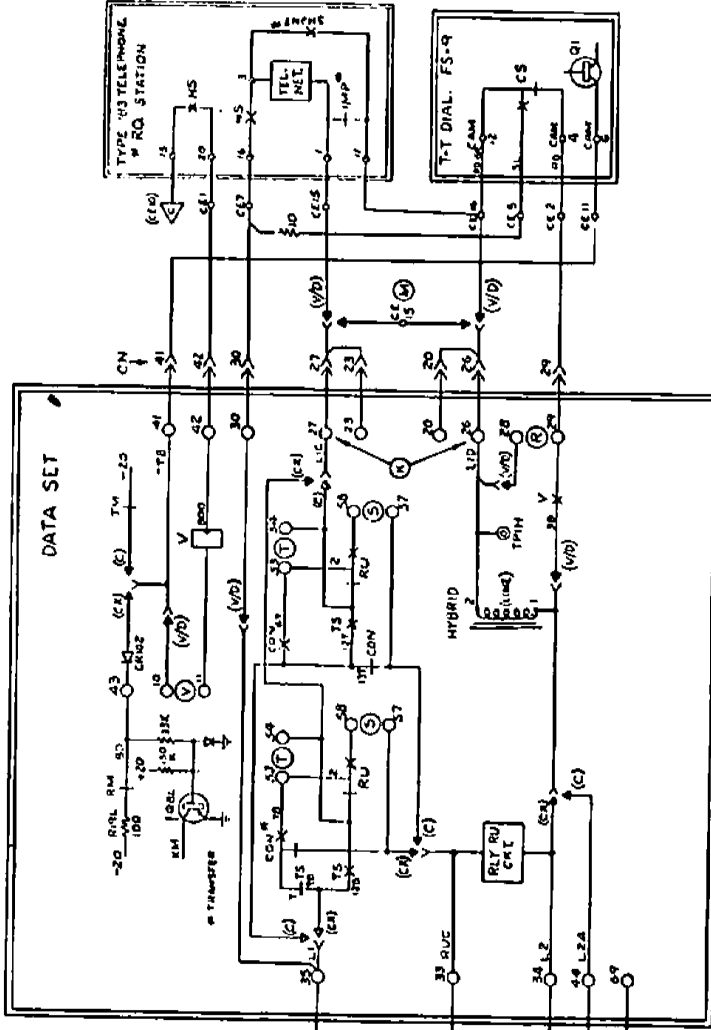
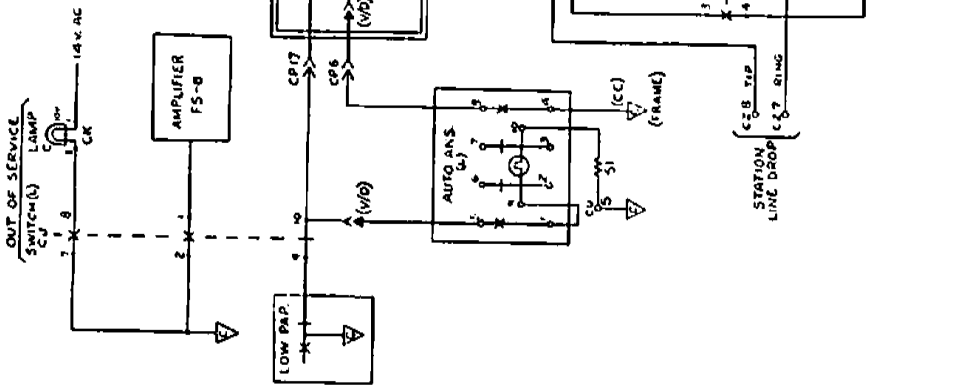

SCHEMATIC WIRING DIAGRAM  
FOR  
MODEL 33 ASR & ASR TTY  
WITH  
AE101C3 DATA SET FAMILY

DATE: 9 12

49-B-0869-1

H. C. Telcott

2-2-58

105

FOR PLANT TRAINING INFORMATION ONLY

**Money: what we spend  
for luxuries and owe  
for necessities**

**FS-15  
PAPER ALARM**

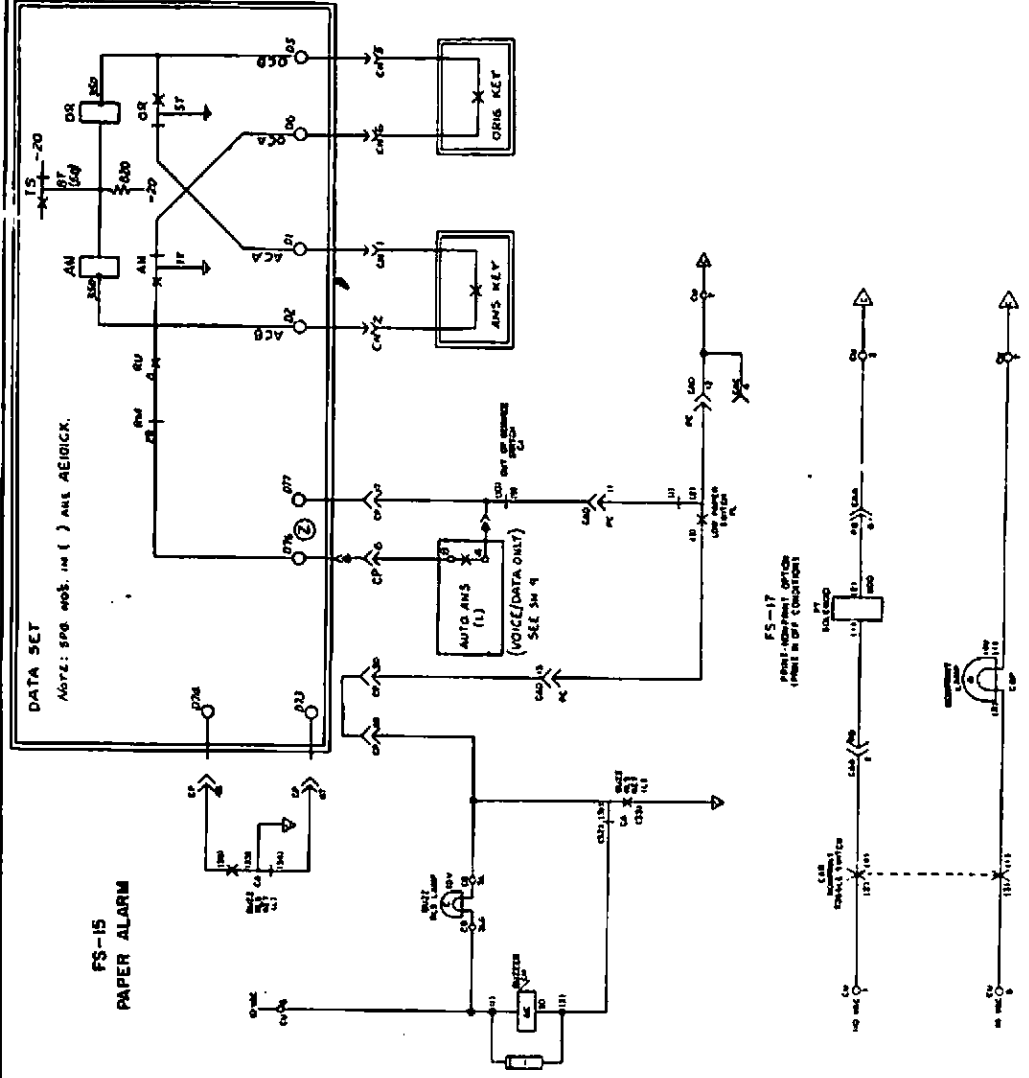

See sheet 1 for notes

R. C. TALBOT <i>RCT</i>		49-B-0869-1-C SHEET 10 OF 12	
SCHMATIC WIRING DIAGRAM FOR MODEL 33 ASR & KSR TTY WITH AETIC DATA SET FAMILY		9-1-67	
R. C. TALBOT 1000 W. 10th St. Lincoln, Nebraska 68502		AUTOMATIC ELECTRIC LABORATORIES, INC. 1000 W. 10th St. Lincoln, Nebraska 68502	
DRAWN BY: <i>RCT</i>		CHECKED BY:	
DESIGNED BY:		APPROVED BY:	
DATE:		SCALE:	



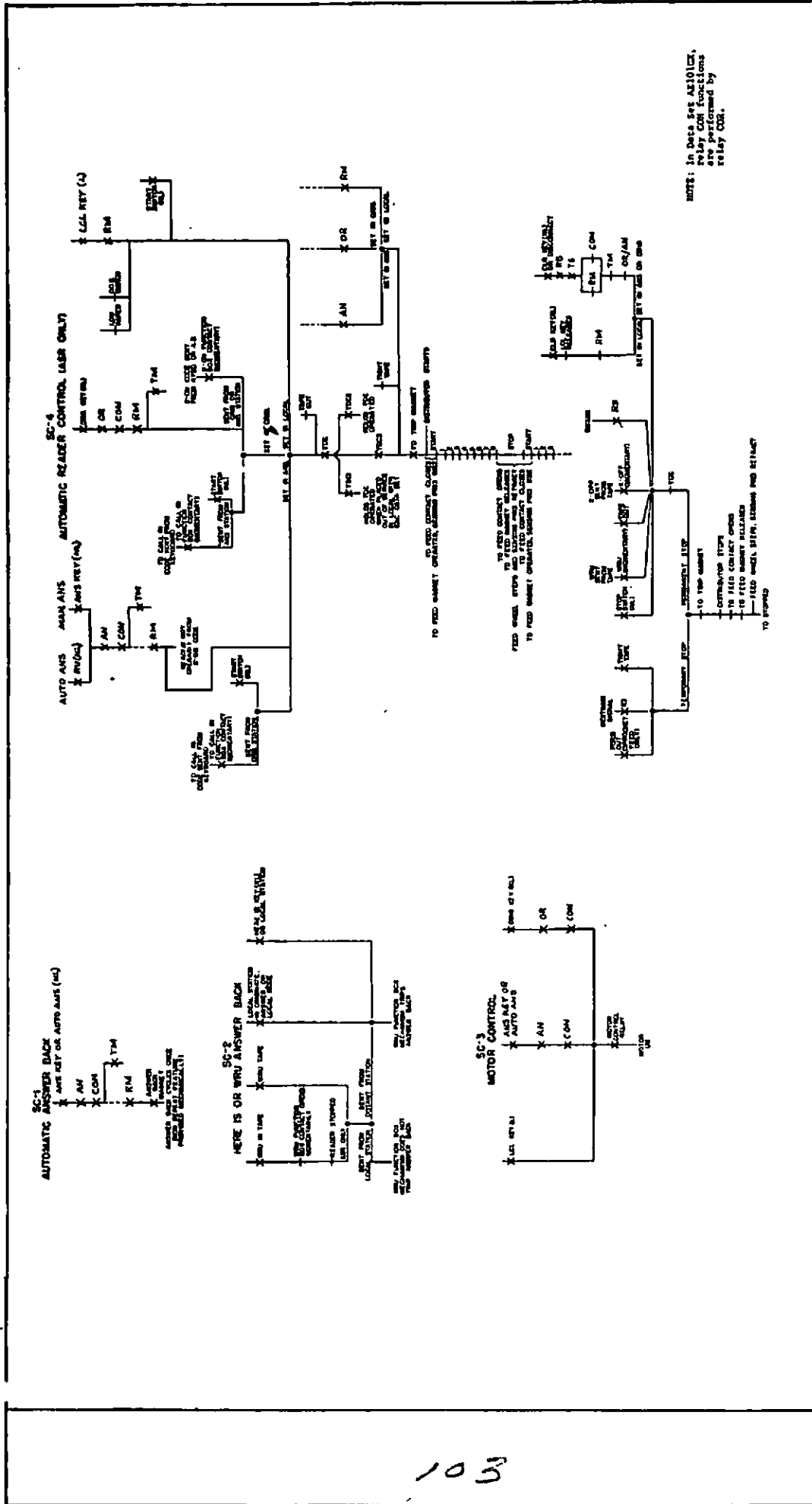

SCHEMATIC WIRING DIAGRAM MODEL 33 ASR 6 KSR TTY WITH A2101C DATA SET FAMILY		DATE 49-B-0869-1-C REV. 12 OF 12
NAME M. G. YALOWITZ	TITLE P-1-67	ORGANIZATION AUTOMATIC ELECTRIC LABORATORIES, INC. NORTHVALE, ILLINOIS, U.S.A.
PROJECT NO. 373	DRAWING NO. 49-B-0869-1-C	SCALE AS SHOWN

**A job becomes work only when you worry about it**

**MODEL 33 CALL CONTROL UNIT**

**See the following General System Practices for related  
Call Control information:**

- A. 574-123-101 -- Principles of Operation
- B. 574-123-800 -- Parts