

Vector Network Analyzers

Barry2 k3eui



What Devices do Network Analyzers Test?

Filters

RF Switches

Couplers

Cables

Amplifiers

Antennas

Isolators

Mixers

...

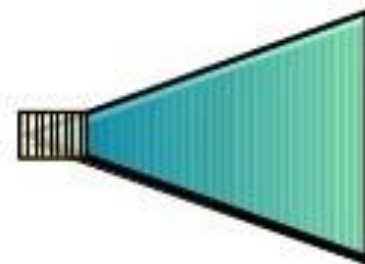

Most 2 (or more) port devices (and some 1 port devices)

Flow Chart: Vector Network Analyzer

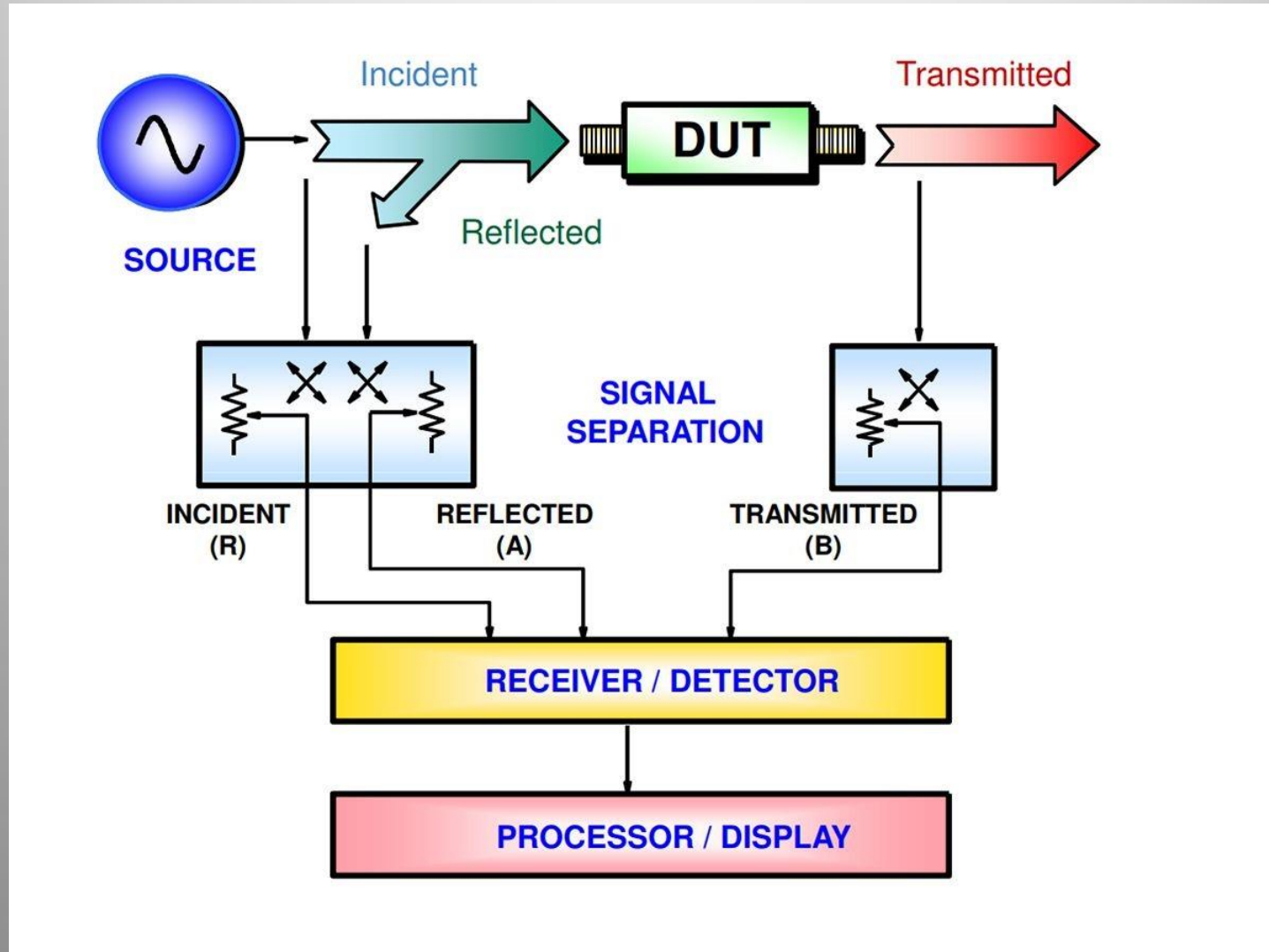

Network Analyzers Vs Spectrum Analyzers

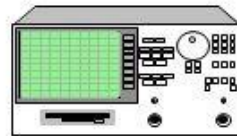
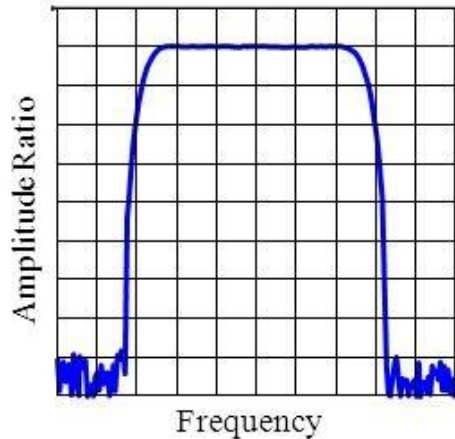

Measures
known signal

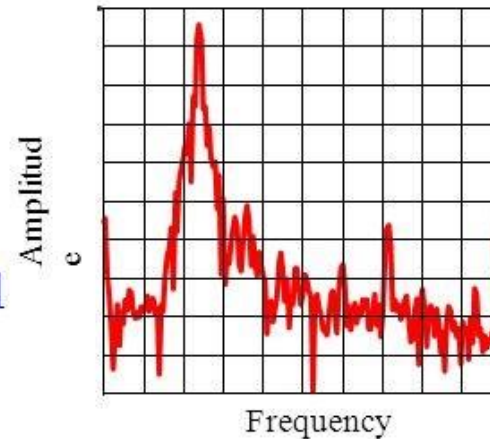

Measures
unknown
signals

Network analyzers:

- measure components, devices, circuits, sub-assemblies
- contain source and receiver
- display ratioed amplitude and phase (frequency or power sweeps)
- offer advanced error correction

Spectrum analyzers:

- measure signal amplitude characteristics (carrier level, sidebands, harmonics...)
- can demodulate (& measure) complex signals
- are receivers only (single channel)
- can be used for scalar component test (*no phase*) with tracking gen. or ext. source(s)



Which device would you rather have in your ham shack?
They each cost about \$50

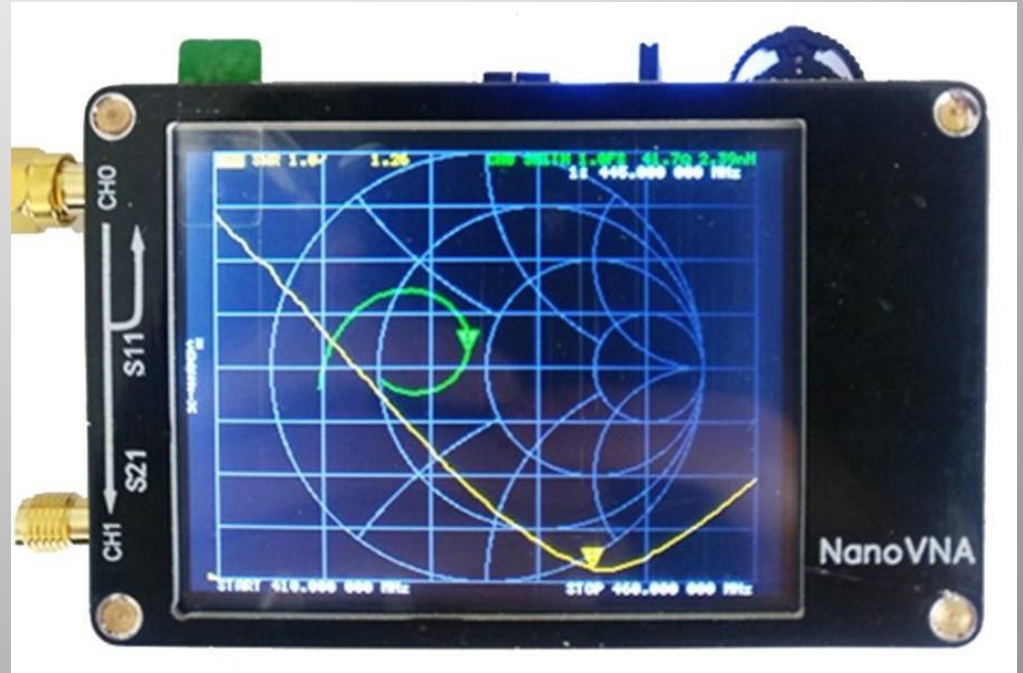

Evolution of MFJ Antenna Analyzers

259D measures frequency, SWR, Resistance, Reactance, Impedance

223 can display graphs in multiple colors and scan bands



Rig Expert has many models with various graphical displays



Comet makes a nice looking Antenna Analyzer
note the analog scales measure **SWR** and **Impedance**



Rohde & Schwarz: can you afford this portable one?

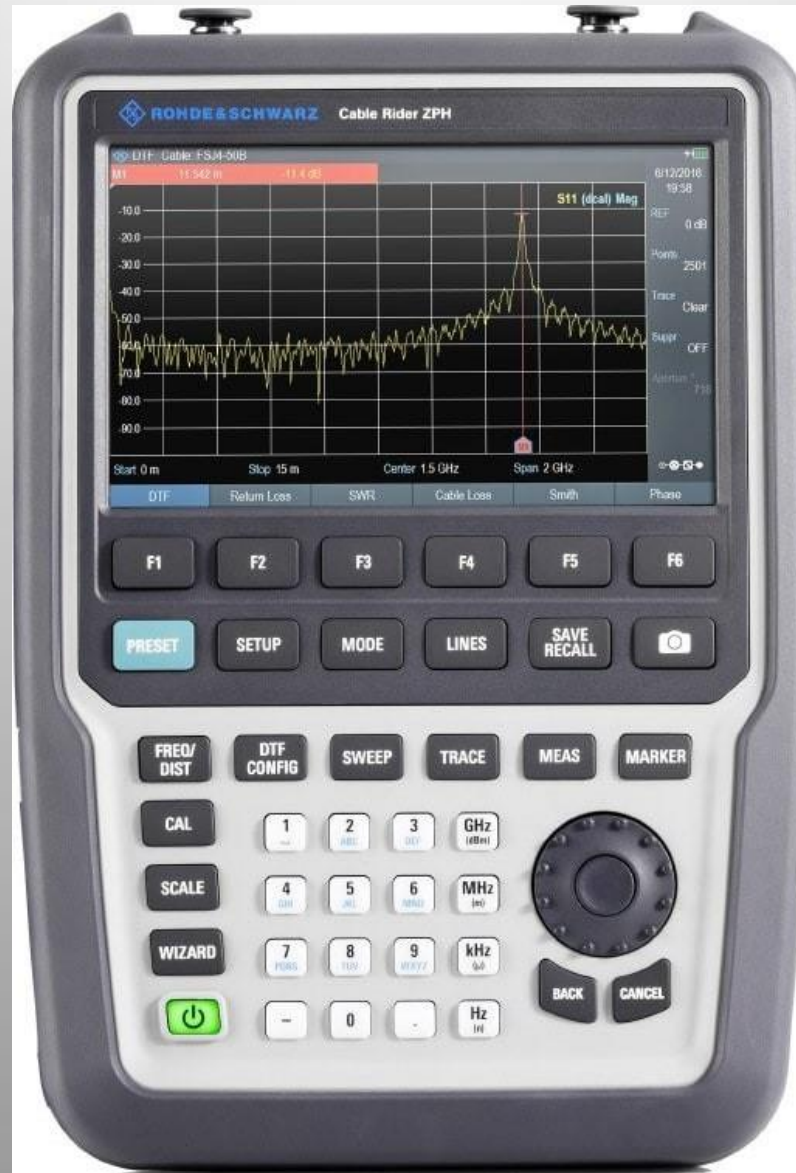

The “high-end” Vector Network Analyzers



Can you afford this beauty? 10 MHz to 20 GHz
Four ports and 9 graphs in color

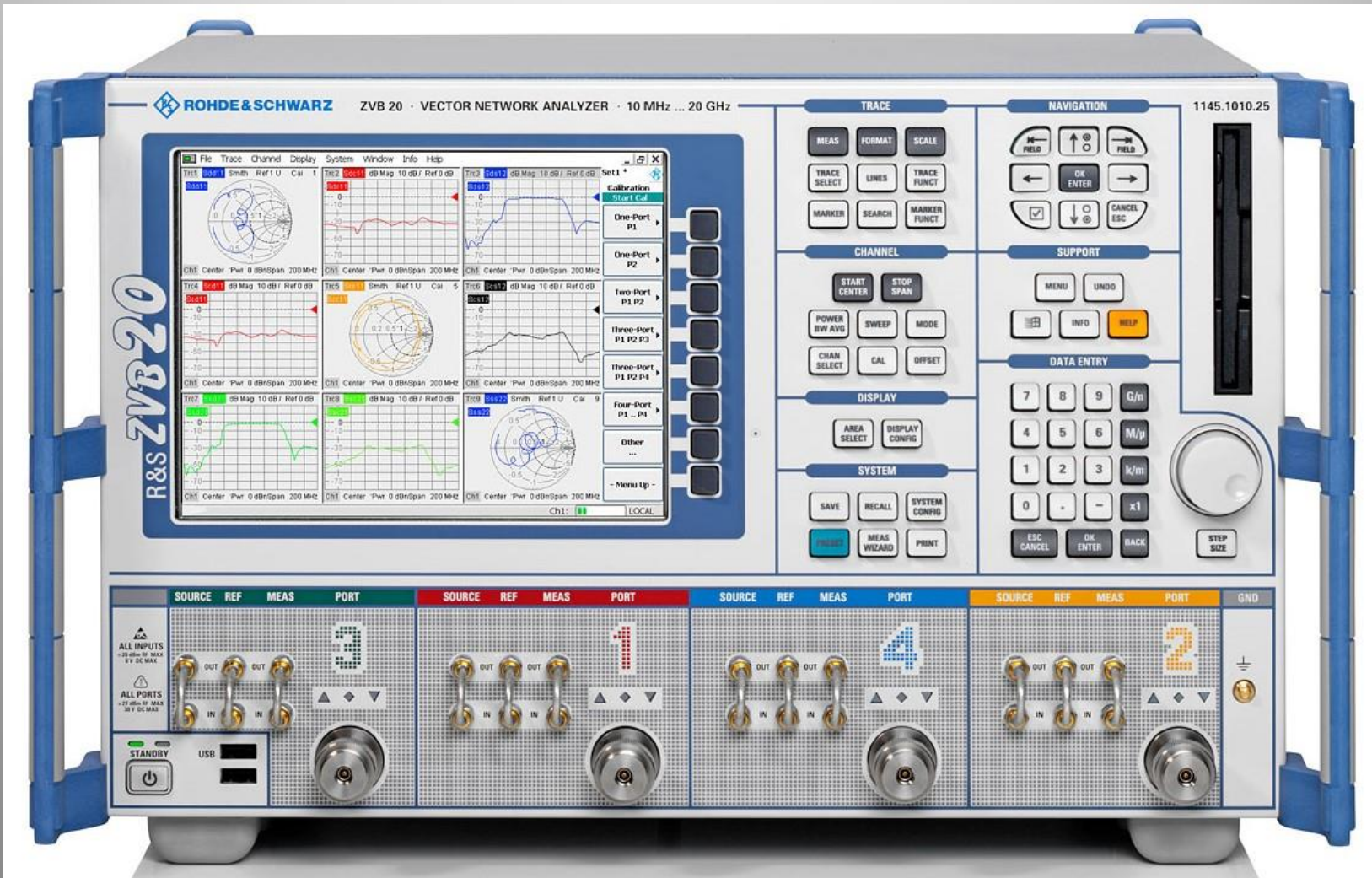

Enter the Nano VNA instrument USB connectivity

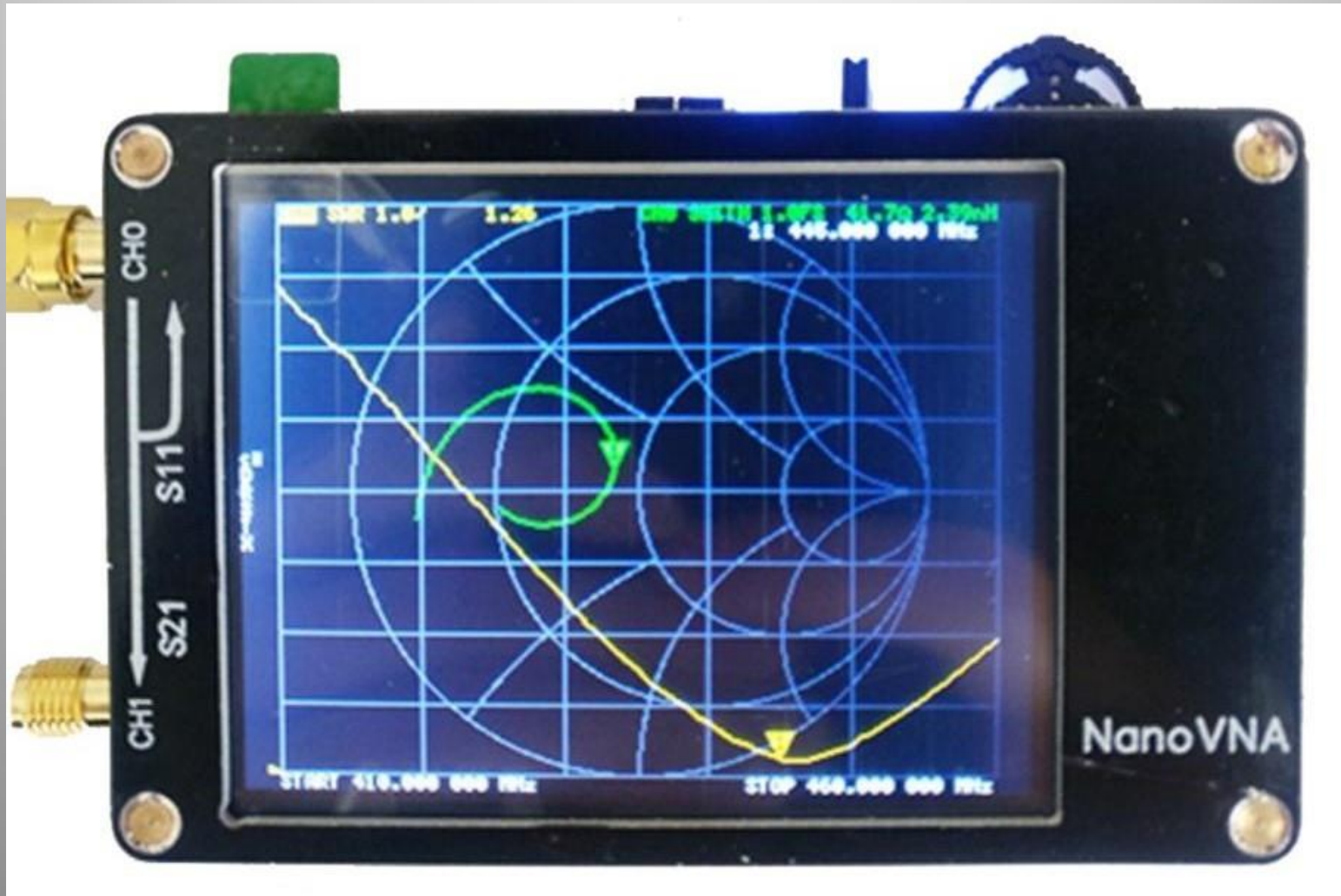

The VNA measures the $V(\text{forward})$ and the $V(\text{reflected})$ signals at various frequencies as a vector (magnitude and phase)

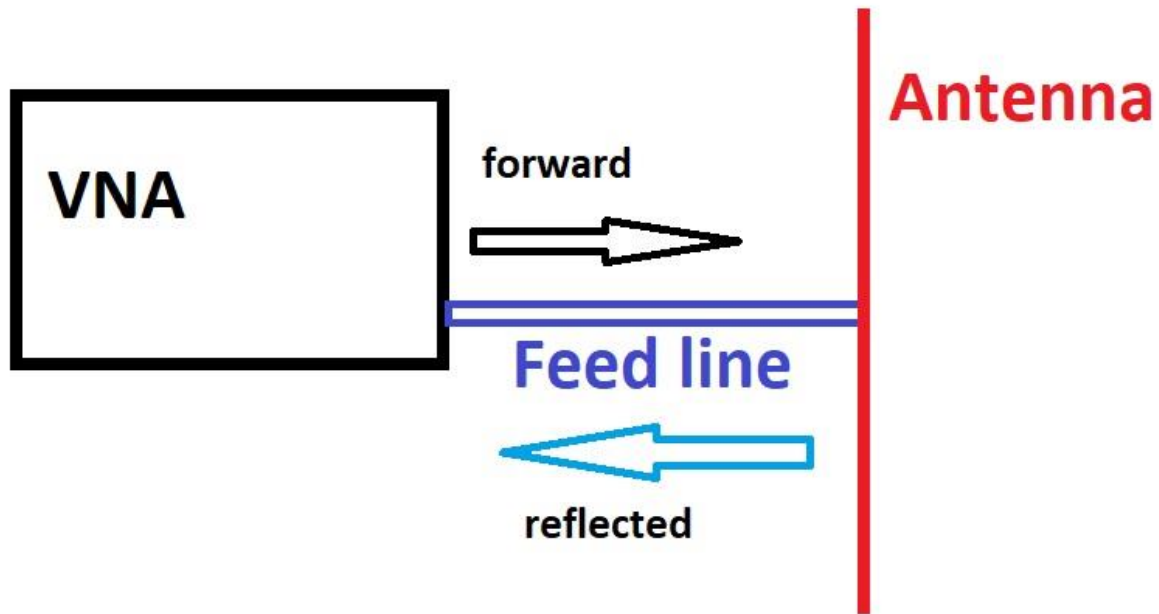

FORWARD - REFLECTED - THROUGH signals

DUT = "device under test"

typical reference impedance = 50 ohms

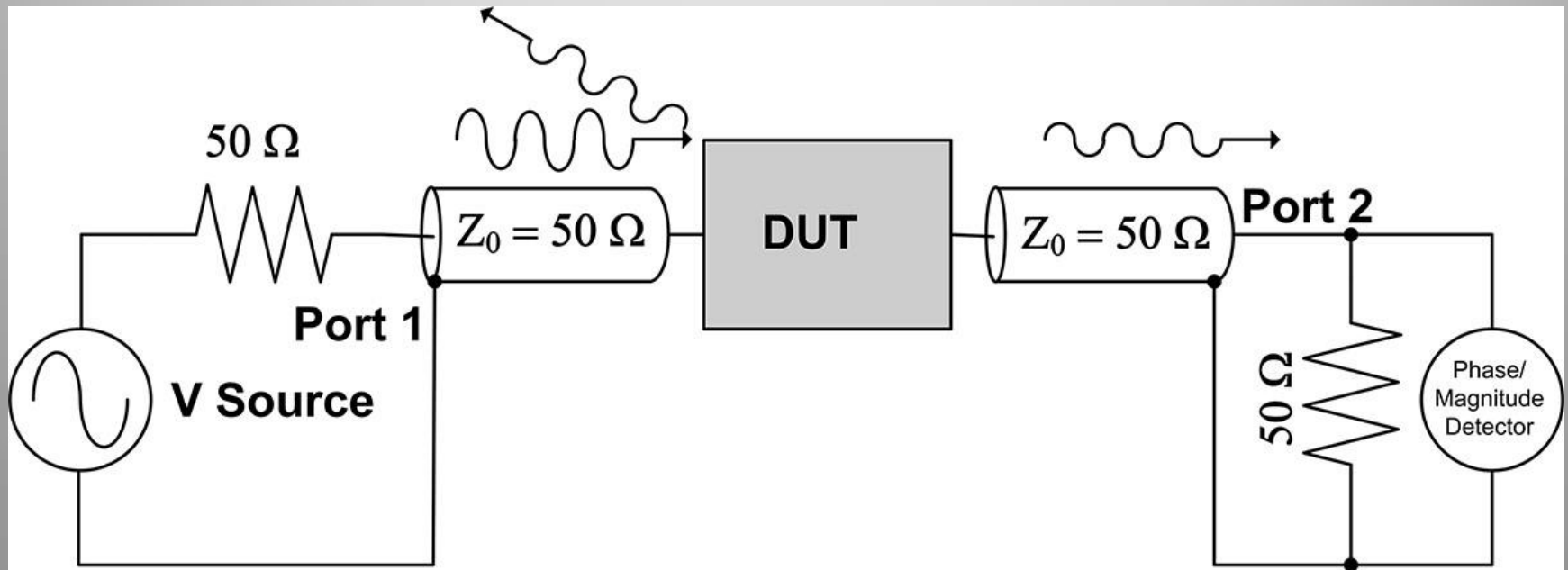

Two “ports”: Ch 0 and Ch 1
4 traces in 4 colors, touch screen



Measurement limit of 101 data points
internal battery for field work

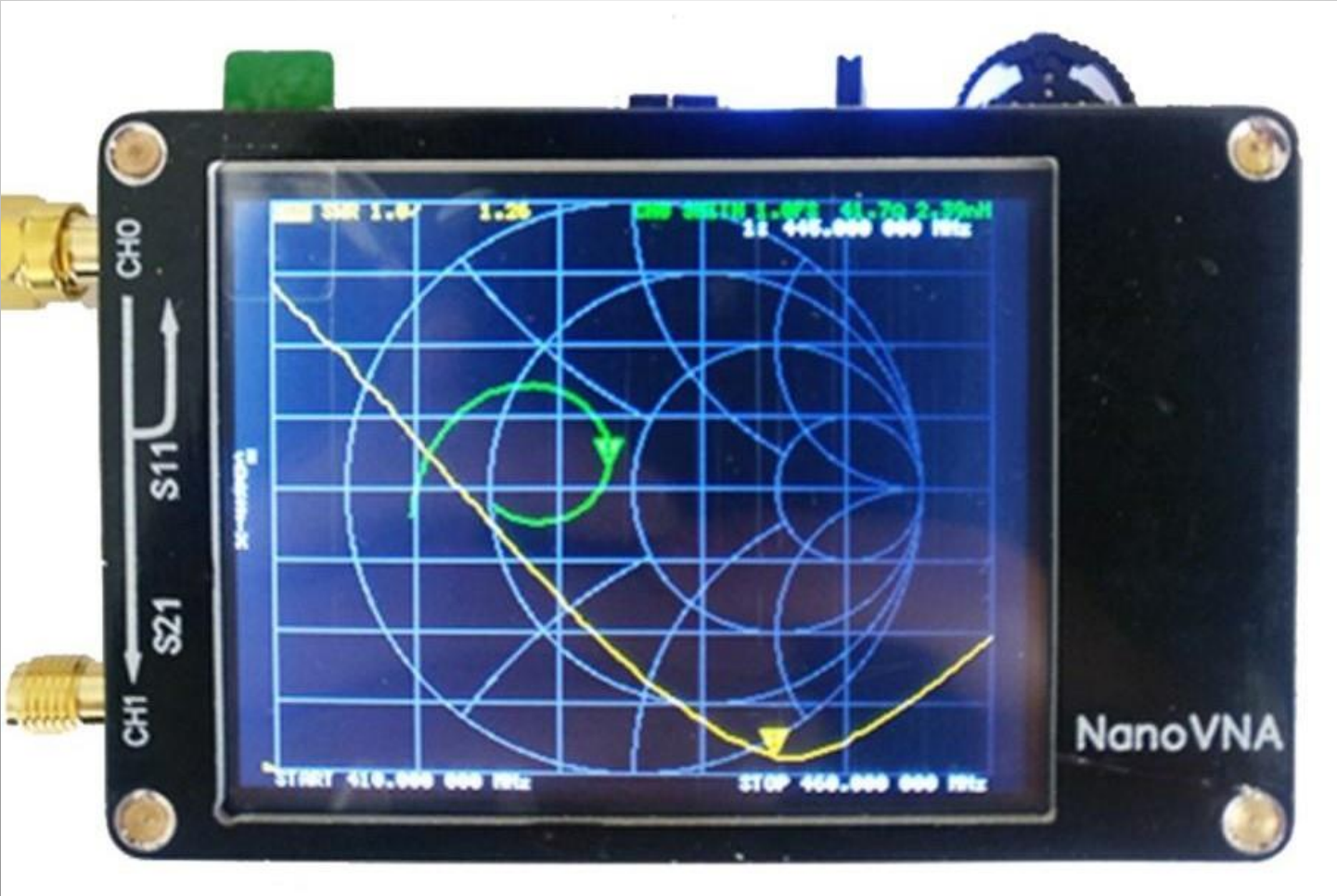

Important Parameter Definitions

Reflection coefficient = V (reflected) / V (forward)

Γ (gamma) = a complex number

absolute value $|\text{gamma}| = \rho$ (rho)

$$0 < \rho < 1$$

RETURN LOSS (dB) = $-20 \log(\rho)$

usually written as a positive number since $\log(\rho)$ is <0

SWR = $(1 + \rho) / (1 - \rho) = V(\text{max}) / V(\text{min})$

Reflection Parameters

- Return Loss, VSWR, Impedance, and Scalar Reflection Coefficient are calculated from measured Vector Reflection Coefficient (Γ)

$$\text{Reflection Coefficient } (\Gamma) = \frac{V_{\text{reflected}}}{V_{\text{incident}}} = \rho \angle \Phi = \frac{Z_L - Z_0}{Z_L + Z_0}$$

$$\rho = |\Gamma|$$

$$\text{VSWR} = \frac{V_{\text{max}}}{V_{\text{min}}} = \frac{1 + \rho}{1 - \rho}$$

$$\text{Return Loss} = -20 \log(\rho)$$

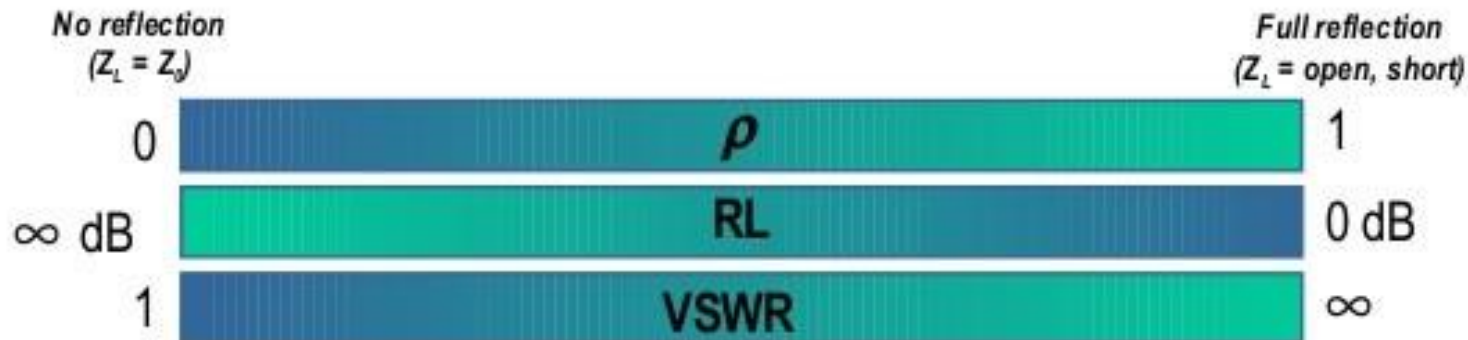

VNA Measurements	Calculated	Calculated
REFLECTION COEFFICIENT	RETURN LOSS (dB)	SWR
0	infinite	1.0
0.1	20.0	1.2
0.2	14.0	1.5
0.3	10.5	2.0
0.4	8.0	2.3
0.5	6.0	3.0
0.6	4.4	4.0
0.7	3.1	5.7
0.8	1.9	9.0
0.9	0.9	19.0
1	0.0	infinite

$$\rho = V(\text{reflected}) / V(\text{forward})$$

$$RL = -20 \log(\rho)$$

$$SWR = (1+\rho) / (1-\rho)$$

Reflection Coefficient ρ vs. VSWR

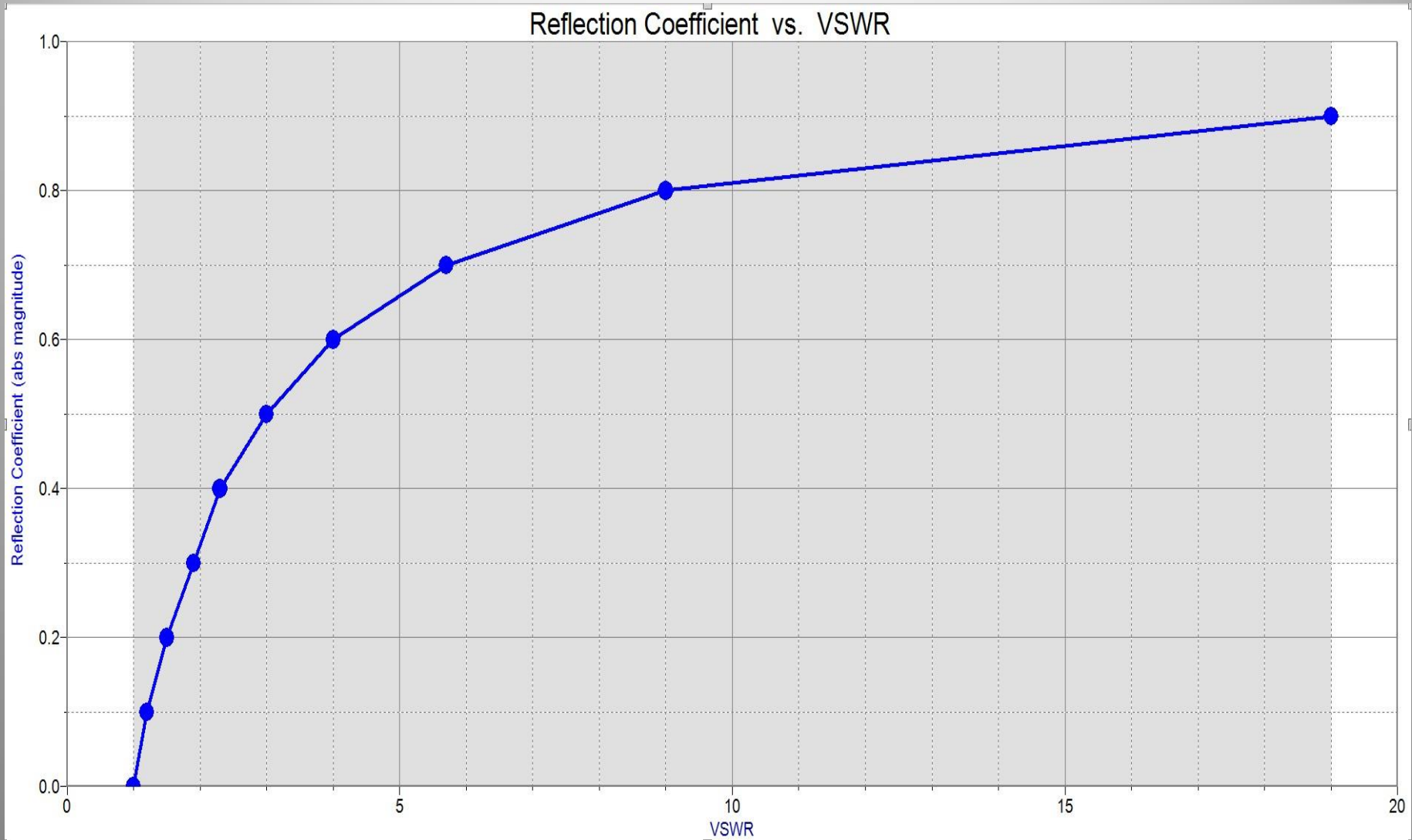

RETURN LOSS (dB) vs. VSWR (you want a high RETURN LOSS)

Return Loss vs. VSWR

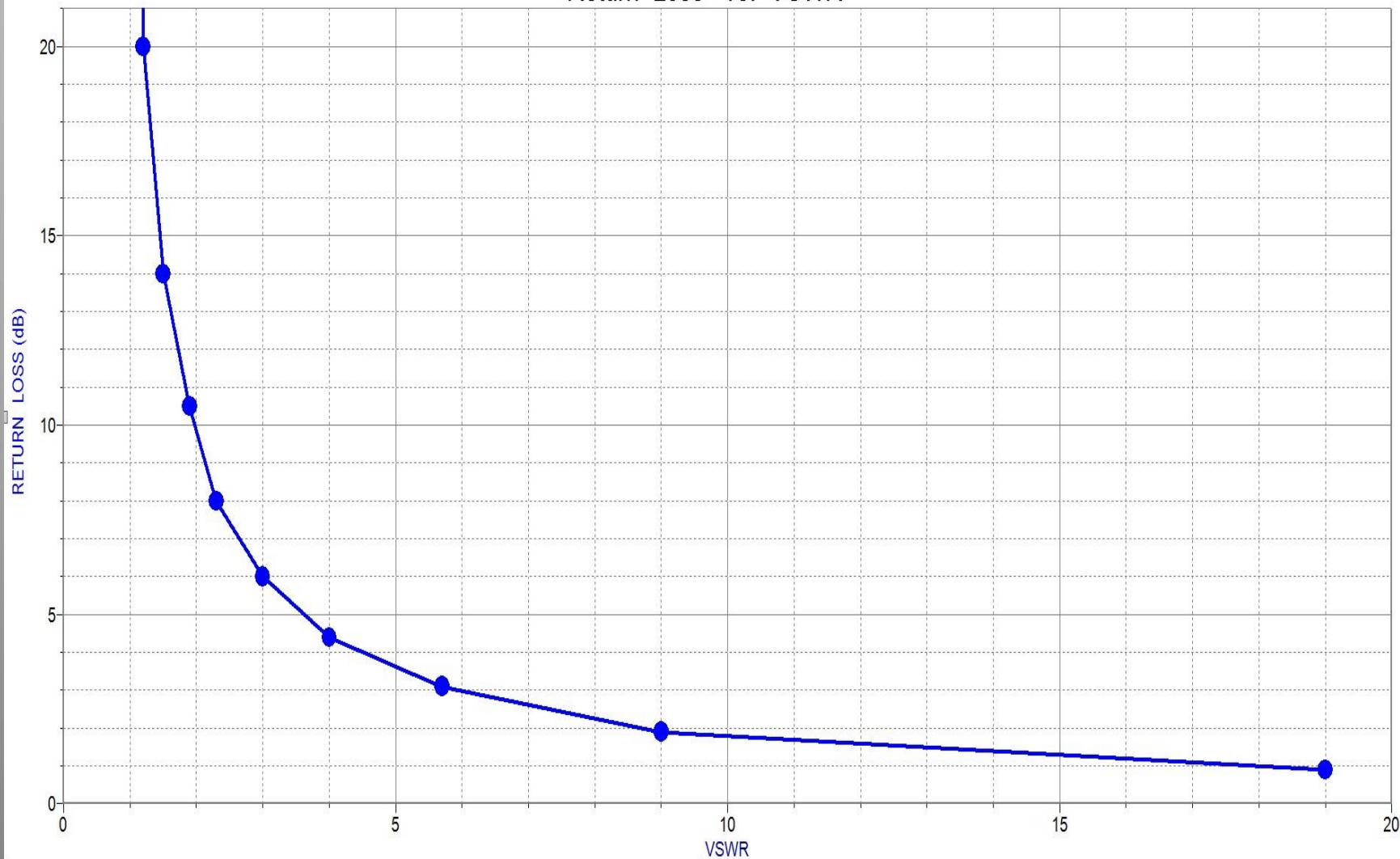

Smith Chart Review

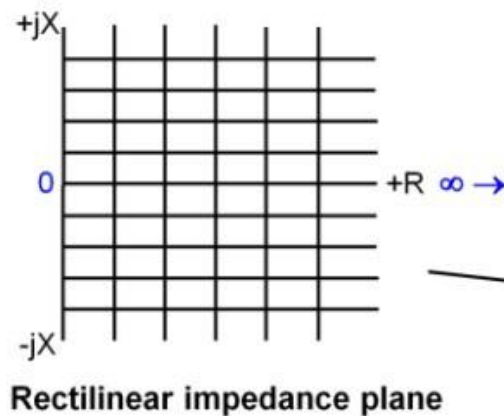

**Smith Chart maps
rectilinear impedance
plane onto polar plane**

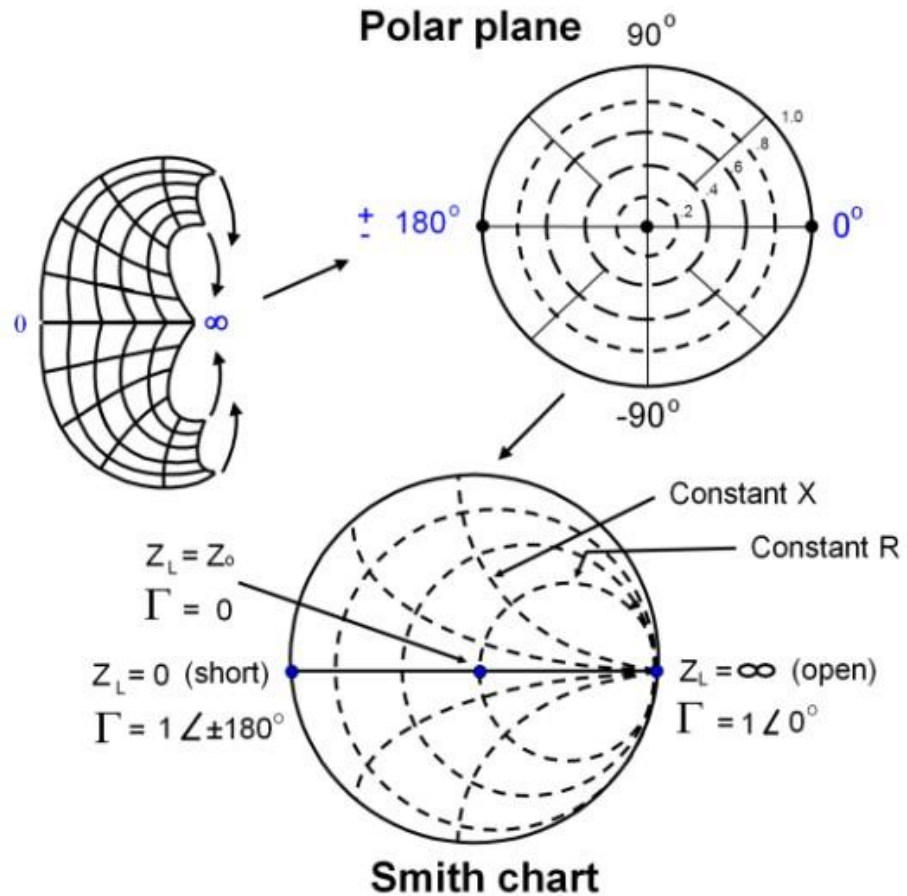

Smith Chart

A graphical representation of **RESISTANCE** and **REACTANCE**

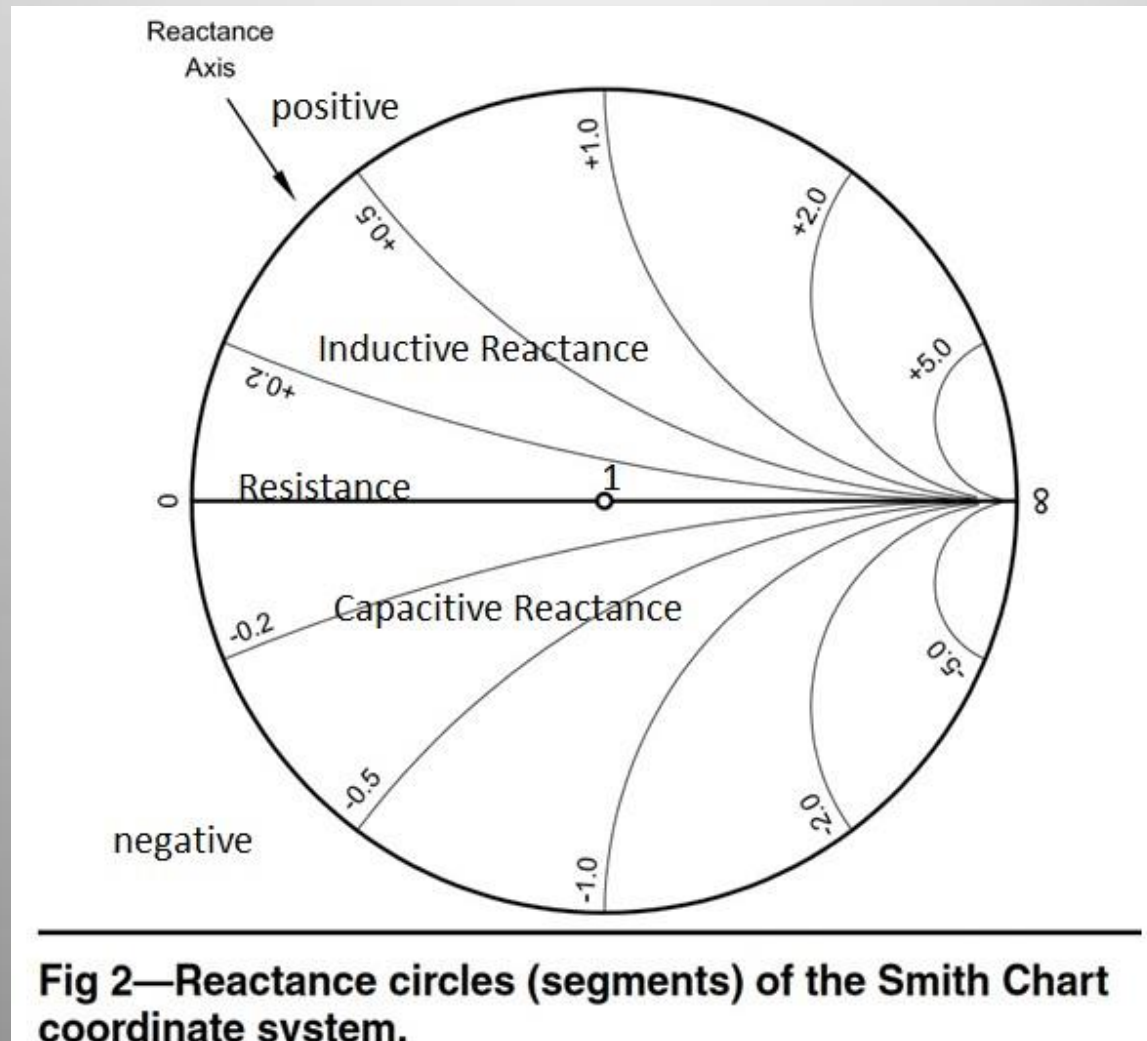

The Bull's Eye can represent 50 ohms RESISTANCE
and zero REACTANCE

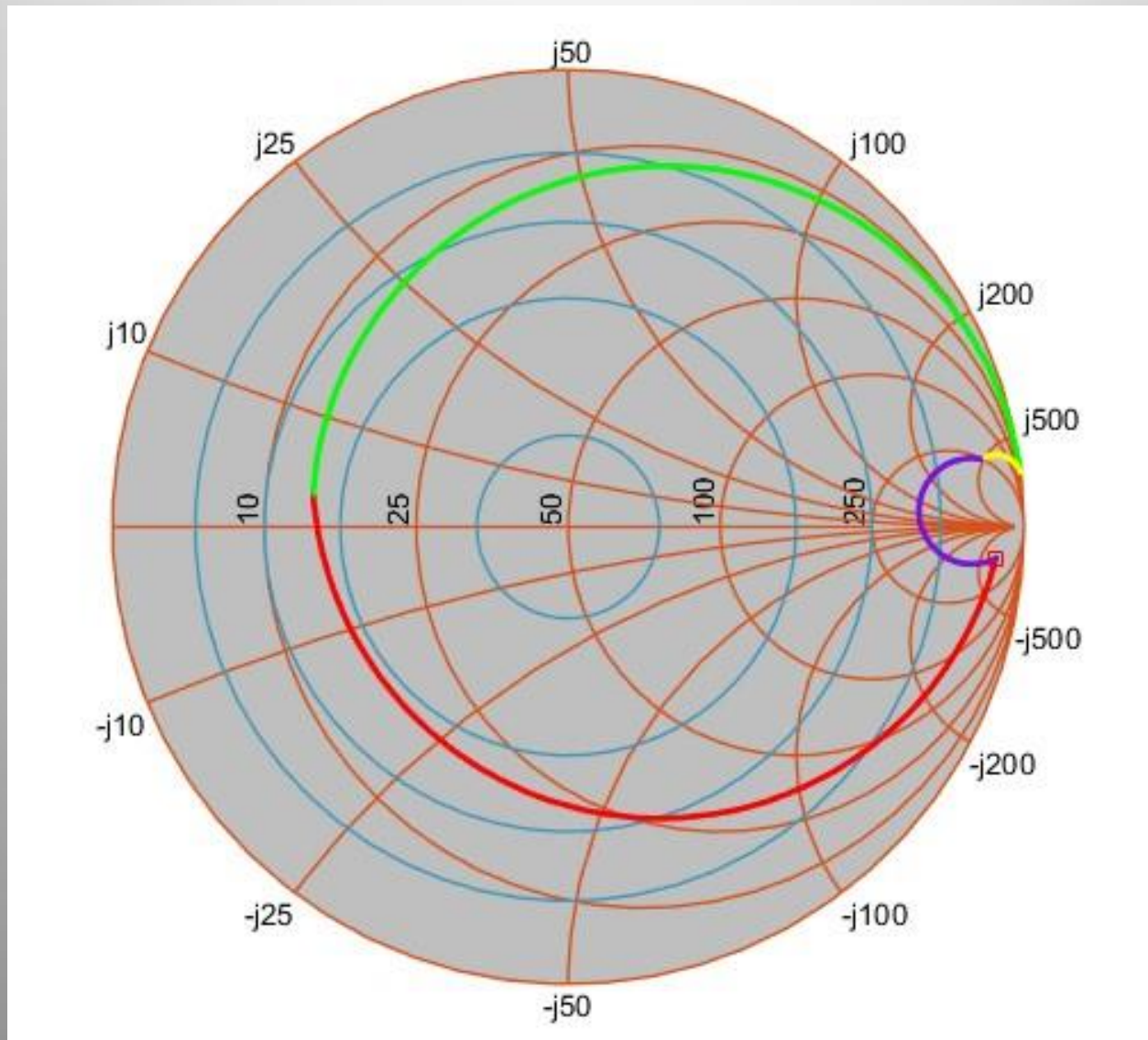

Smith Chart (think DART BOARD)
reflection coefficient ρ and SWR

Bull's Eye = perfect match to 50 ohms with zero reflected power

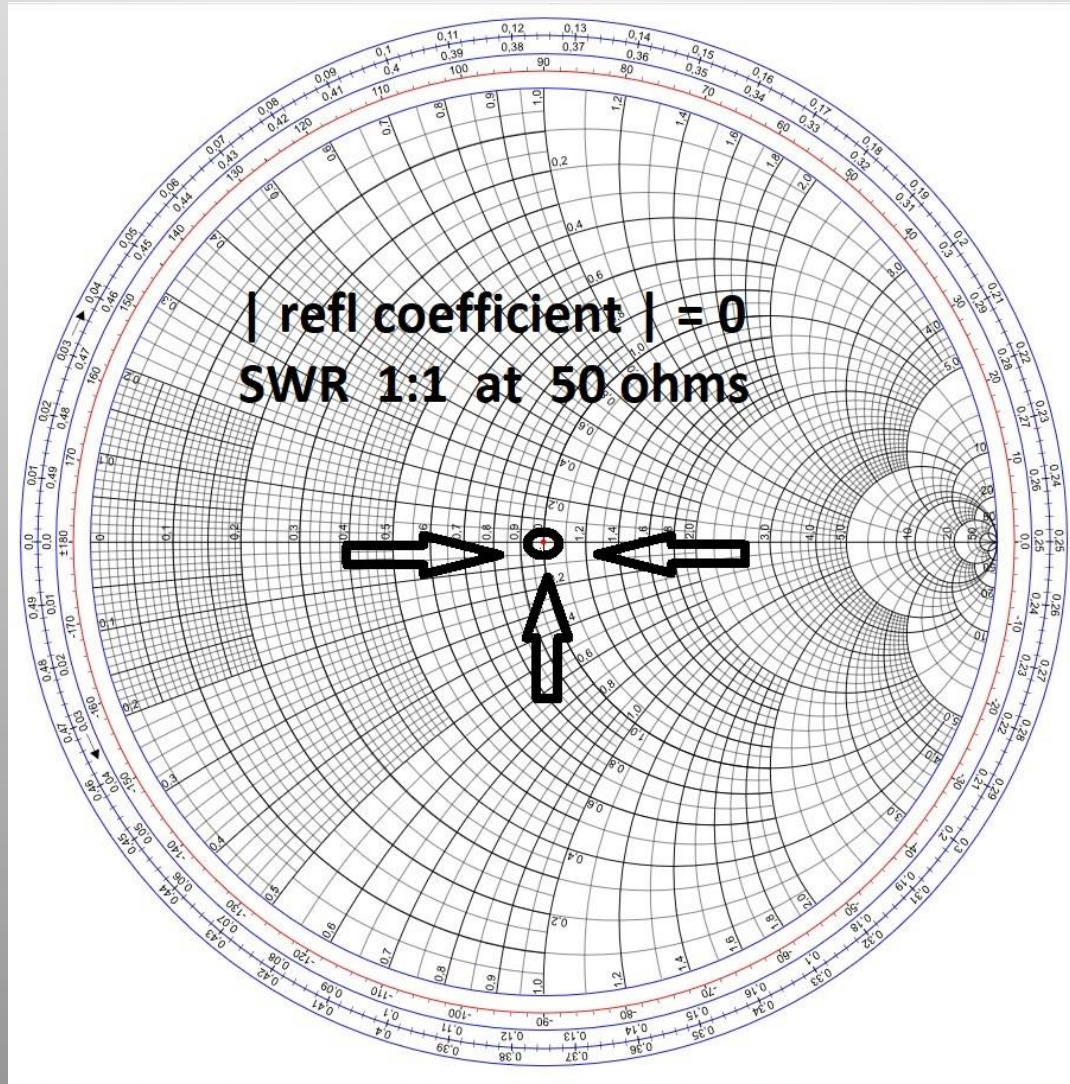

IF 20% of incident voltage is reflected: SWR is 1.5 : 1
All points on the rim represent impedances with $\rho = 0.2$

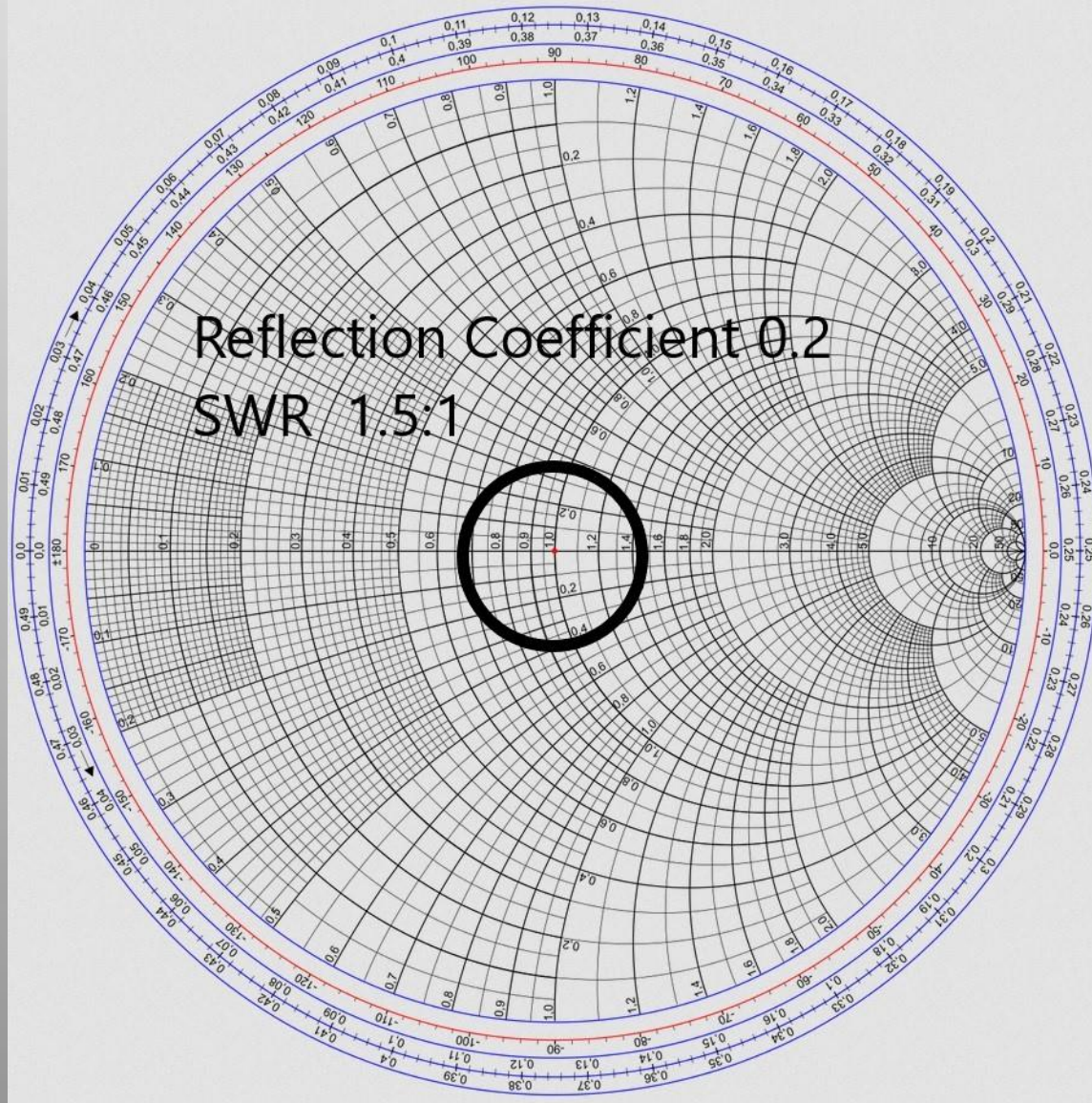

If 33% of incident voltage is reflected
 $\rho = 0.2$ and SWR 2:1

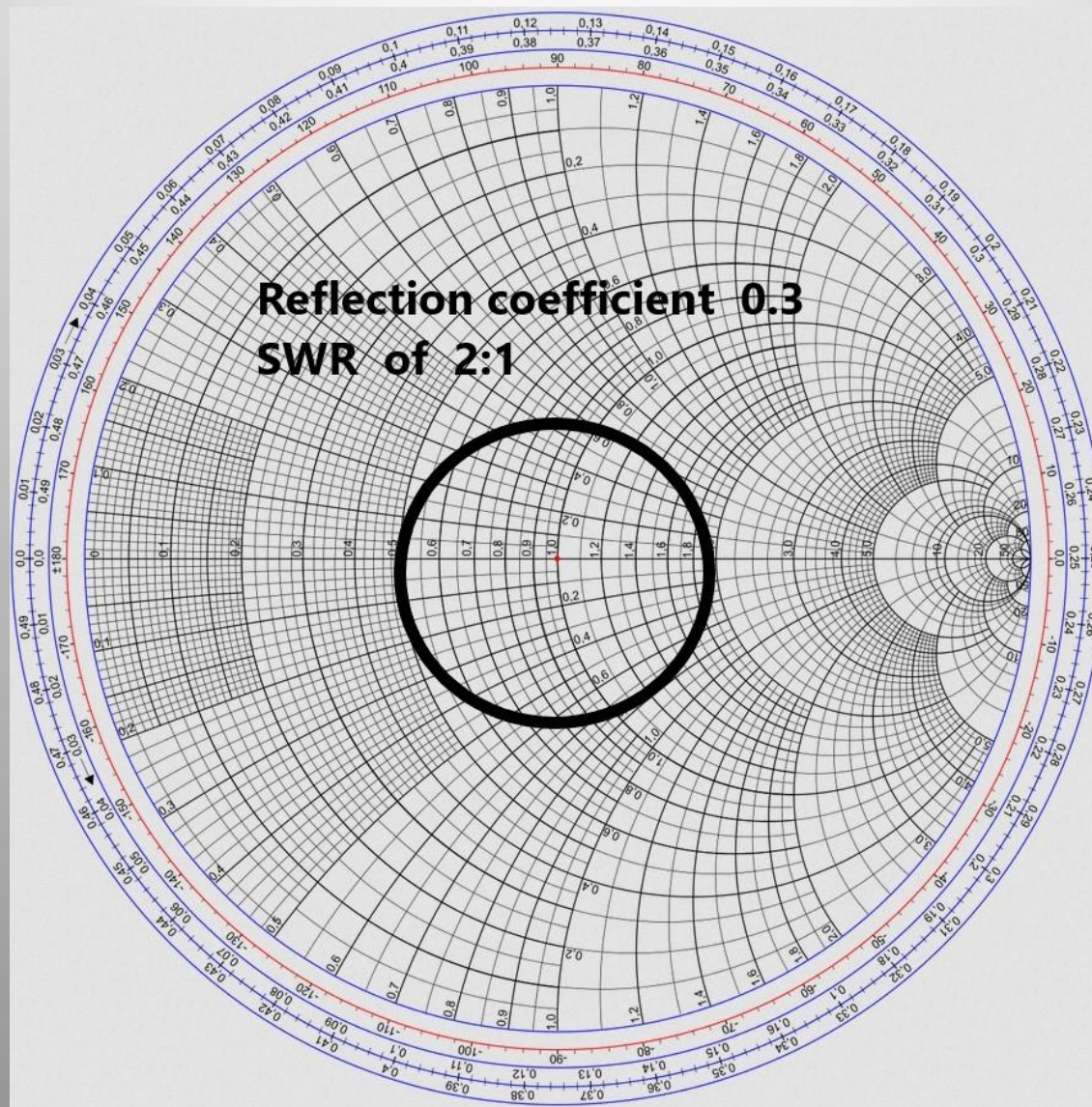

50% of incident voltage is reflected

All values of $R+jX$ on perimeter: $\rho = 0.5$ and SWR 3:1

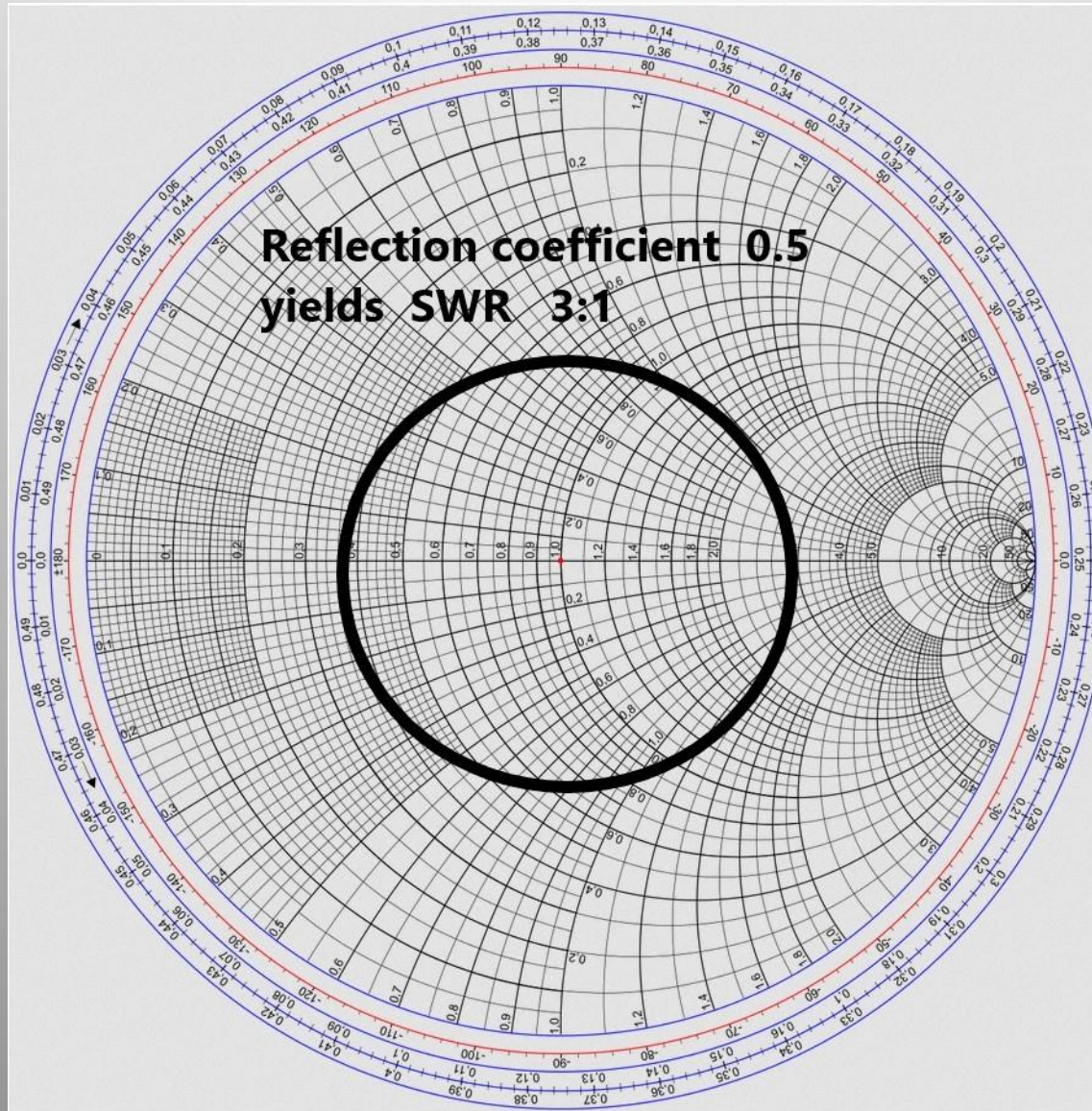

SWR of 4:1 with 60% reflected

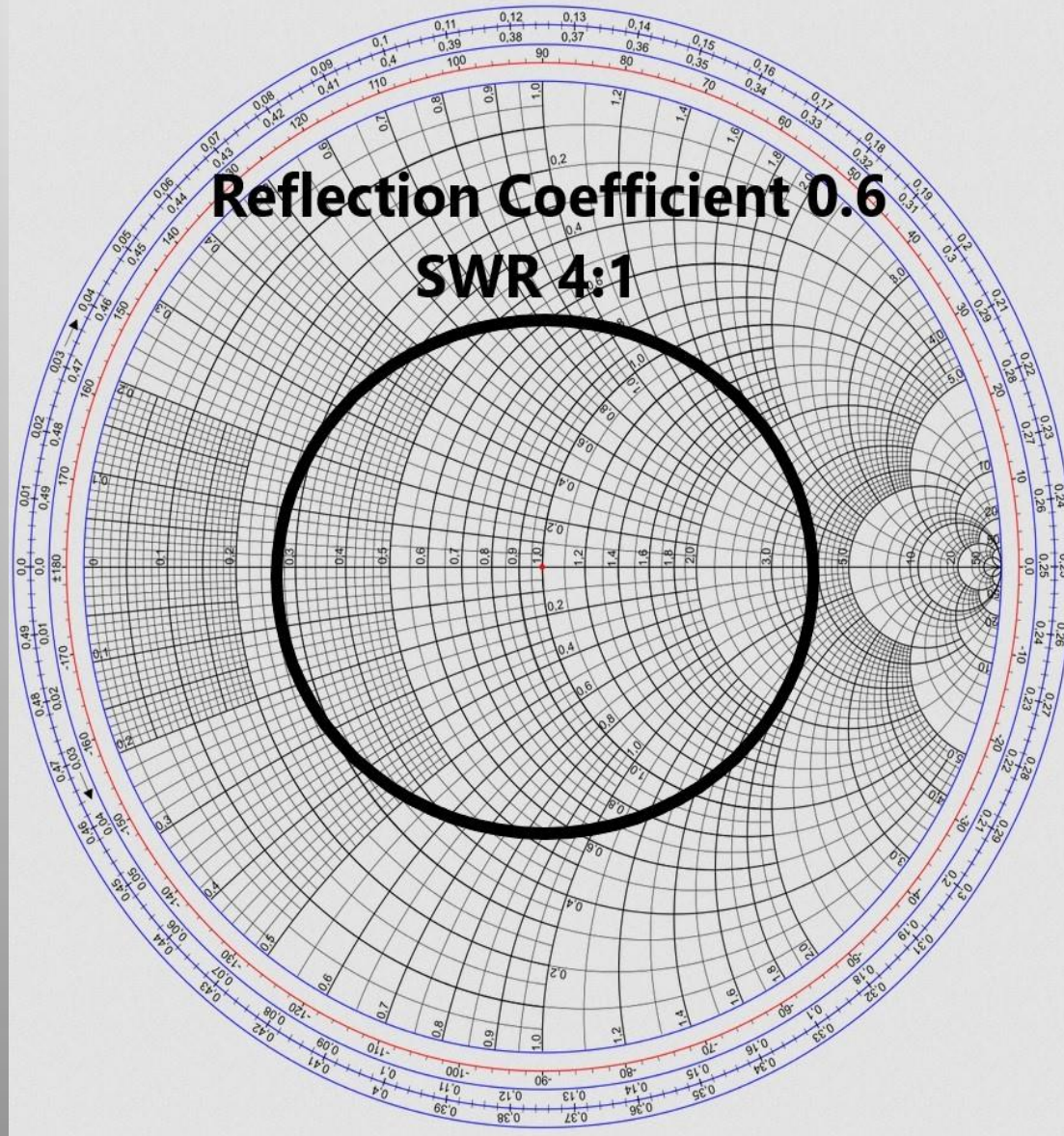

90% reflected $\rho = 0.9 \implies \text{SWR } 20:1$



QUIZ: Where is this antenna resonant?

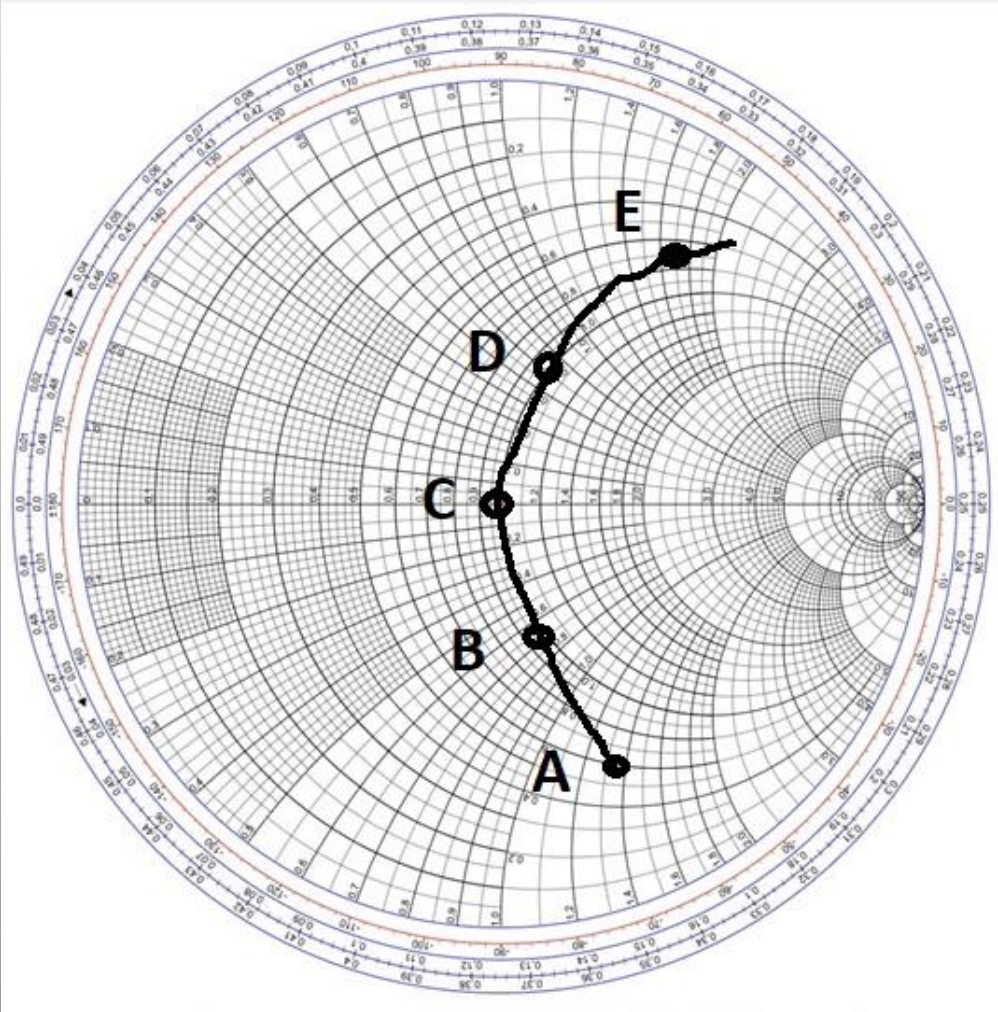

QUIZ: Where is the SWR lowest?

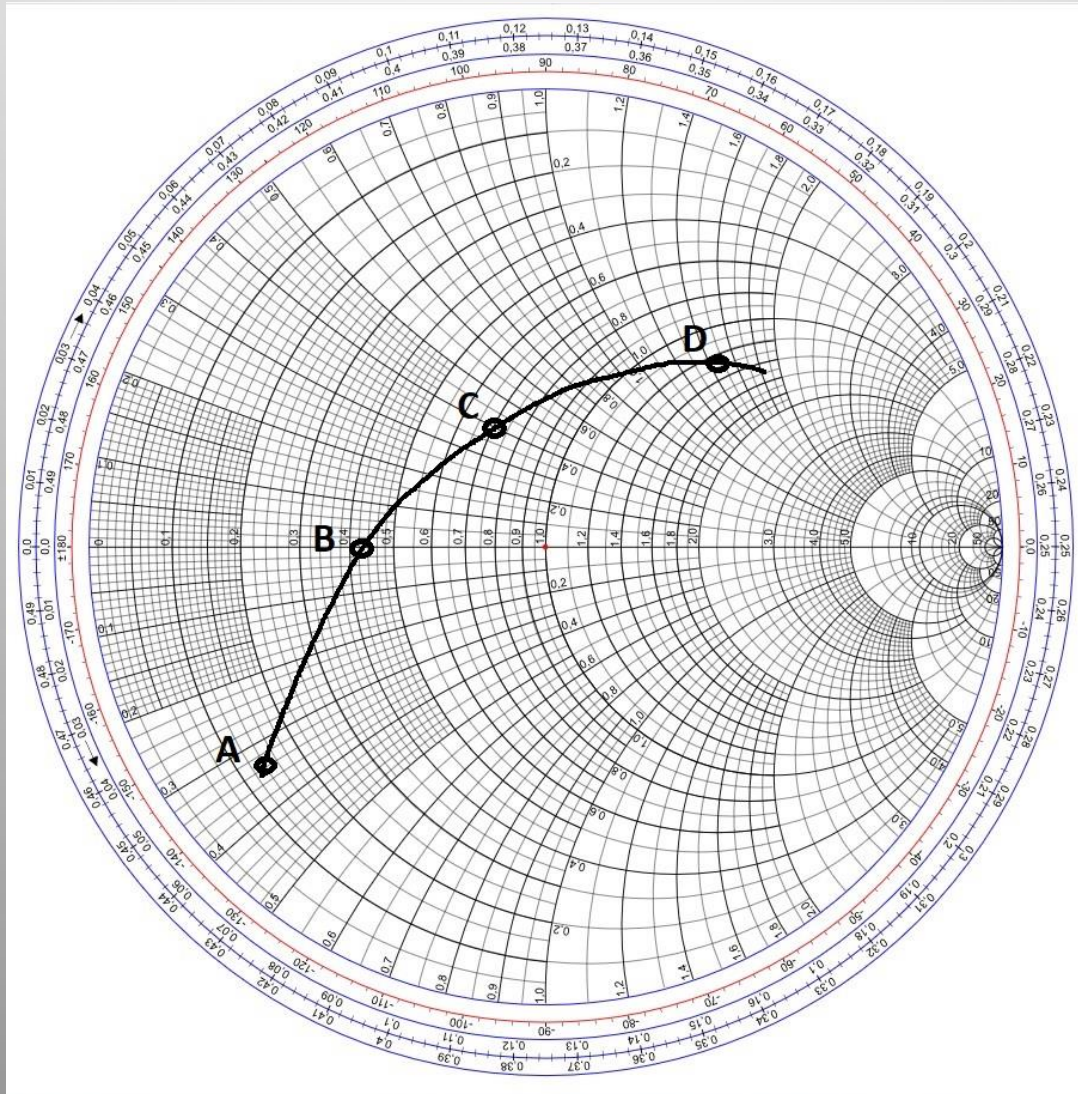

USB connections to computer and battery charger



Useful Cables: SMA to SO239 coax (for use with standard size coax)



Nano VNA Saver software

much easier to use by computer control

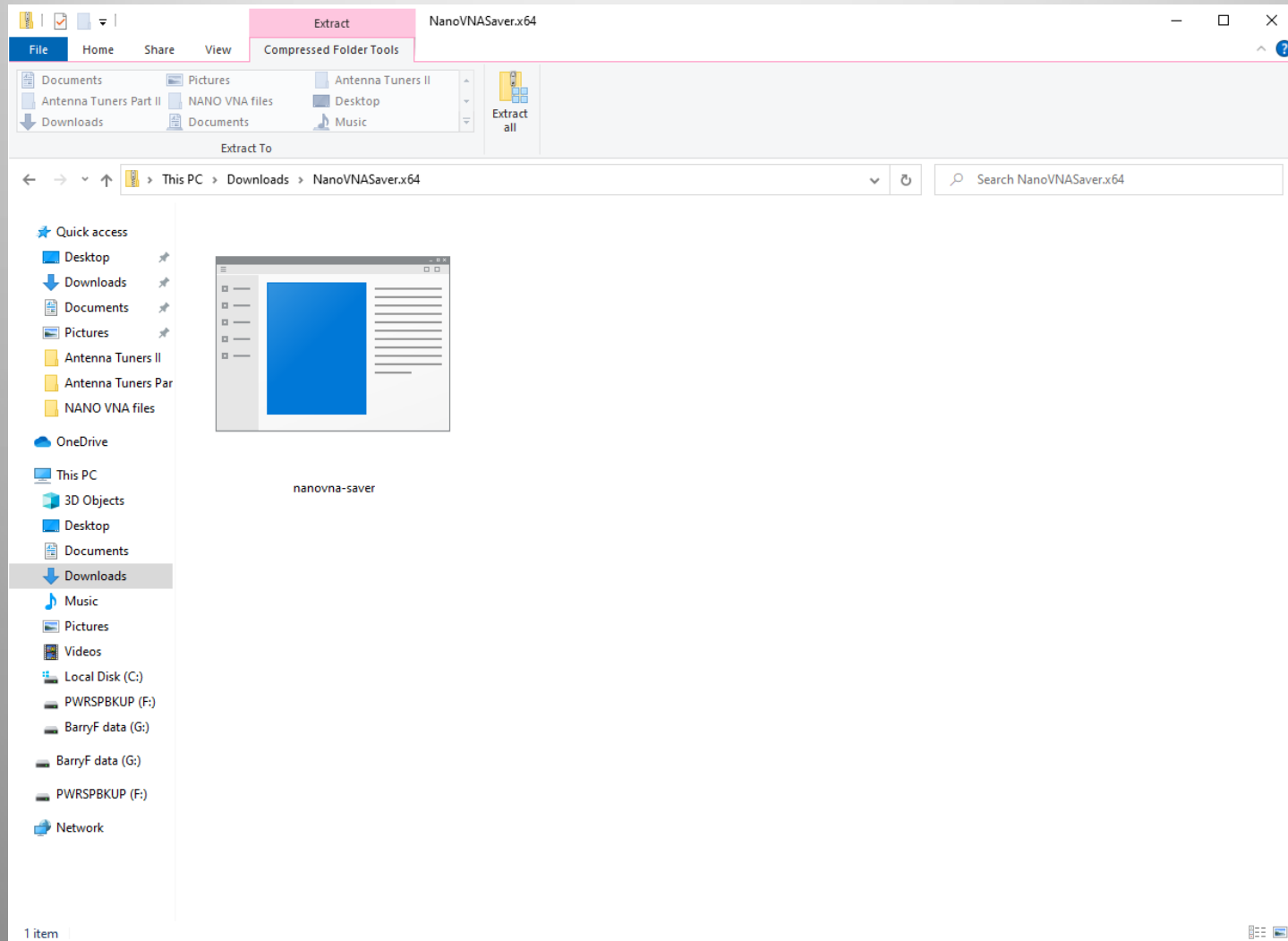

Computer Control Settings

Com Port select
Frequency Range
Select Markers

Sweep resolution ENHANCED
Additional CAL points
SAVE and RETRIEVE files
Display setup of GRAPHS

Sweep control

Start | Center
Stop | Span
 5.000kHz/step

100%

Markers

Marker 1
Marker 2
Marker 3
 Enable Delta Marker
 Locked

TDR

51.933 m

Reference sweep

Serial port control

Choose Graphs to display (up to 6) Colors, etc.

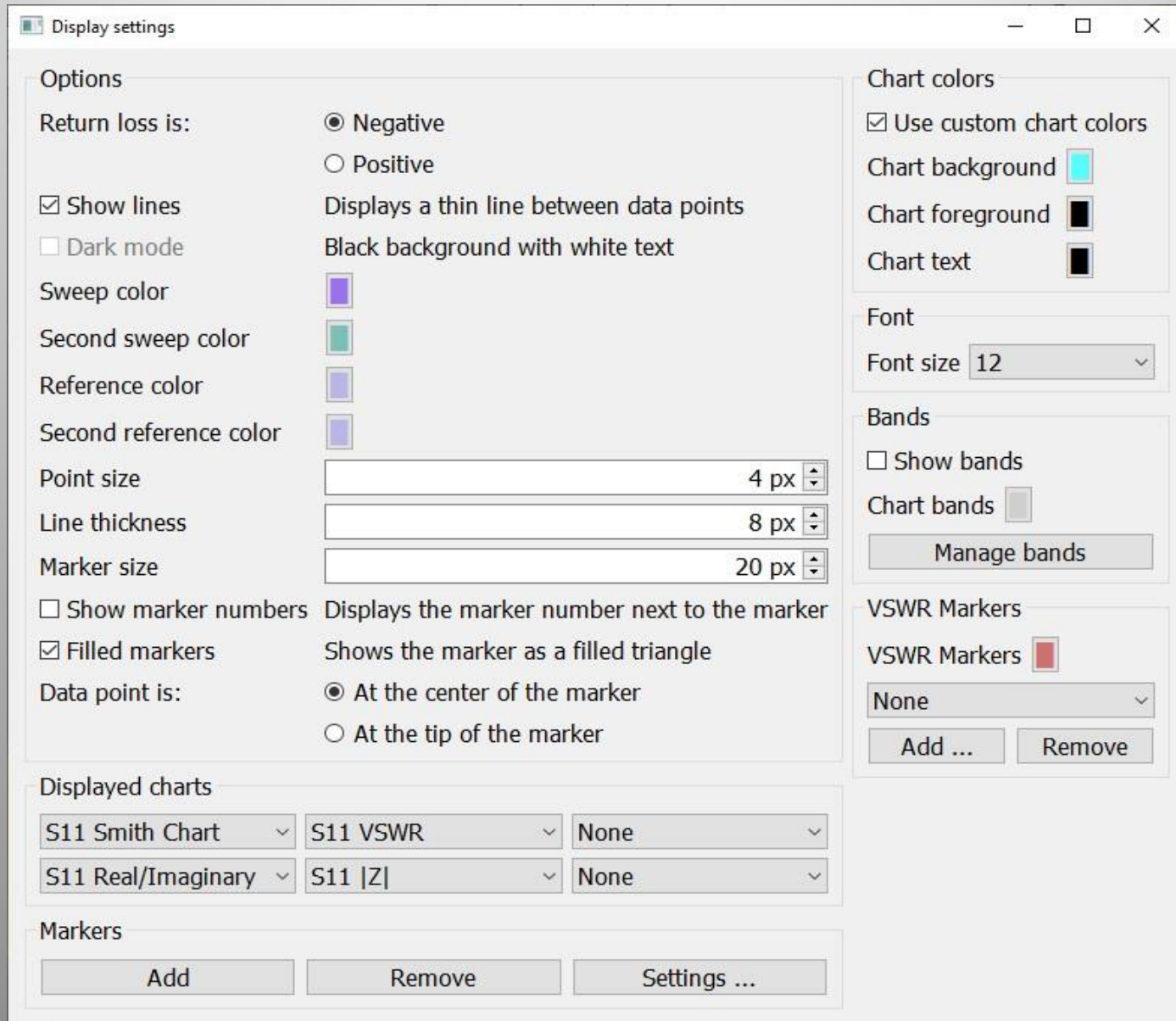

Do a calibration first
Calibration “assistant”

take min of 101 readings

SHORT

OPEN

LOAD

THROUGH two ports

ISOLATION two ports

SAVE CAL files

You can use up to 5000
data points to plot

The screenshot shows the 'Calibration' window with the following elements circled in blue:

- Active calibration: Calibration: Application calibration (101 points)
- Source: Calibration assistant
- Calibrate section: Short, Open, Load, Through, Isolation buttons.
- Offset delay: 0.00 ps
- Calibration assistant button
- Apply and Reset buttons
- Notes section (empty text area)
- Files section: Save calibration and Load calibration buttons
- Calibration standards: Use ideal values checkbox, Short standard, L0-L3 values (all 0), Offset Delay (ps) (0)
- Open standard: C0 (F(e-15)) = 50, C1 (F(e-27)) = 0, C2 (F(e-36)) = 0, C3 (F(e-45)) = 0, Offset Delay (ps) = 0
- Load standard: Resistance (Ω) = 50, Inductance (H(e-12)) = 0, Offset Delay (ps) = 0
- Through standard: Offset Delay (ps) = 0
- Saved settings: New dropdown, Load, Save, Delete buttons

First Step: **CALIBRATE** VNA over a frequency range (MHz)
Calibration standards included as **SMA connectors**
Short, Open, Load (50-ohm), and Through



Calibration: **SHORT** circuit (ZERO R) on far left of the Smith Chart RESISTANCE axis

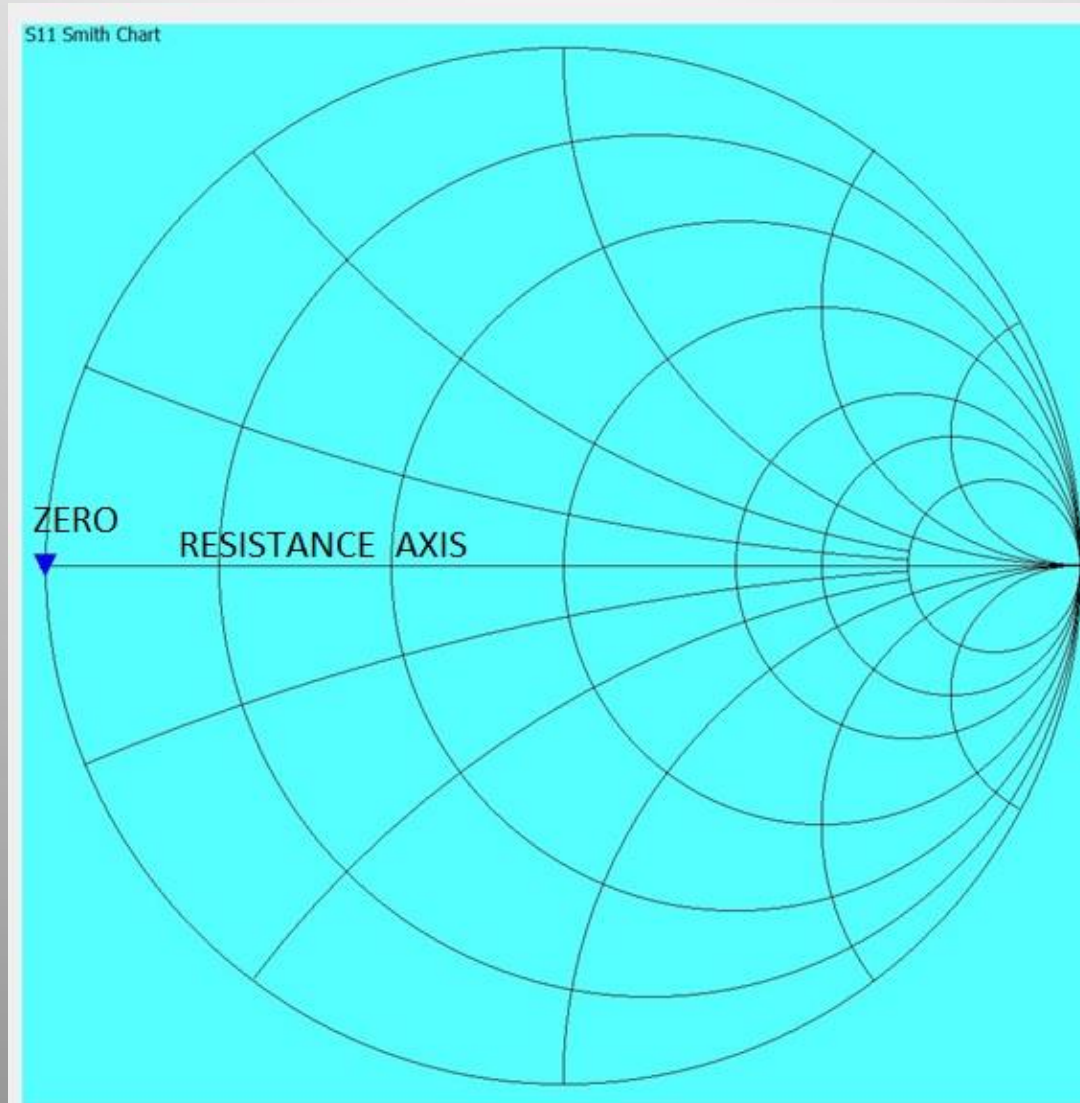

Calibration: **OPEN** circuit (infinite R) on far right of the RESISTANCE axis

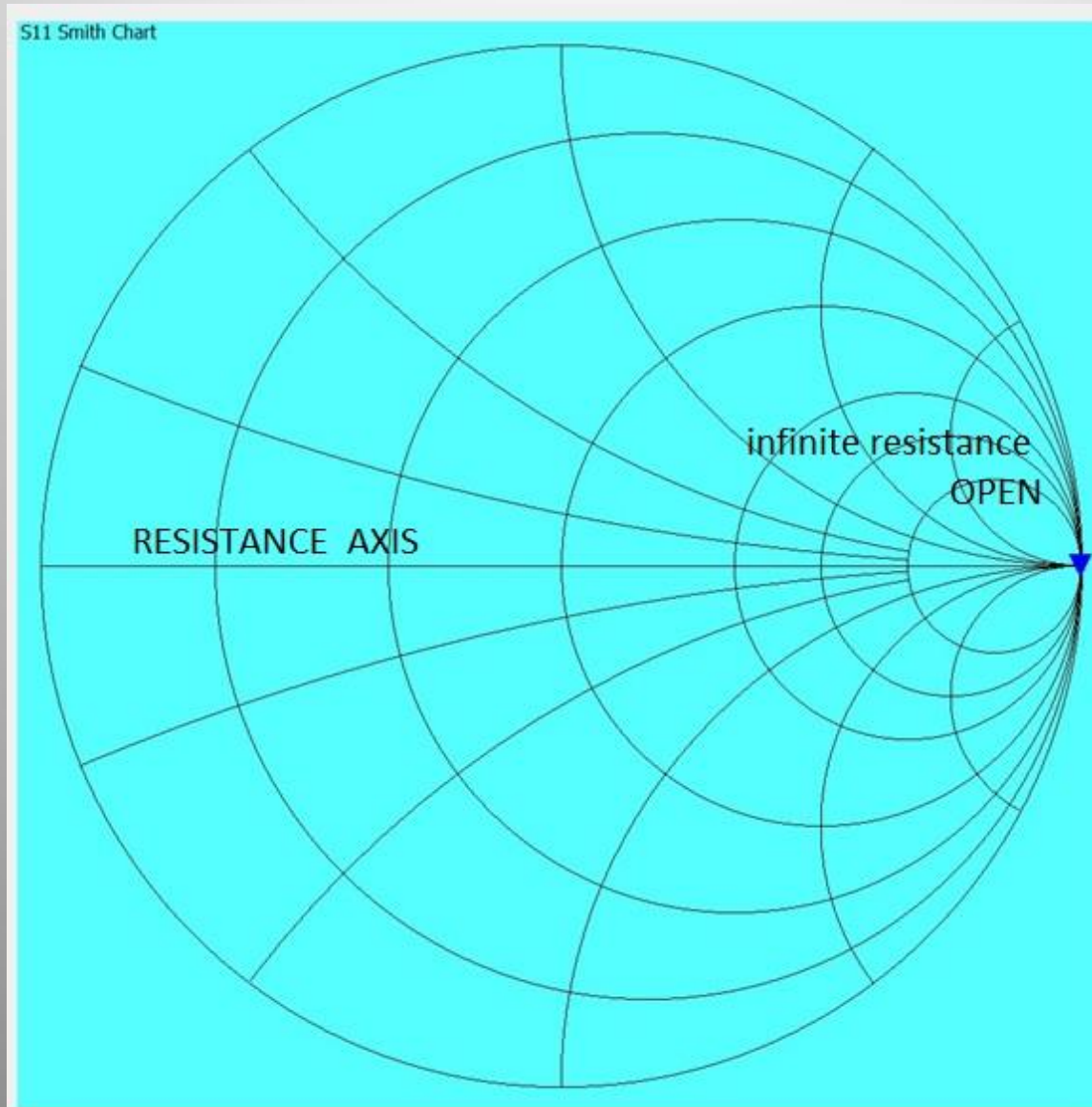

Calibration: 50-ohm **LOAD** (prime center)
middle of the RESISTANCE scale: normalized to **1.0**

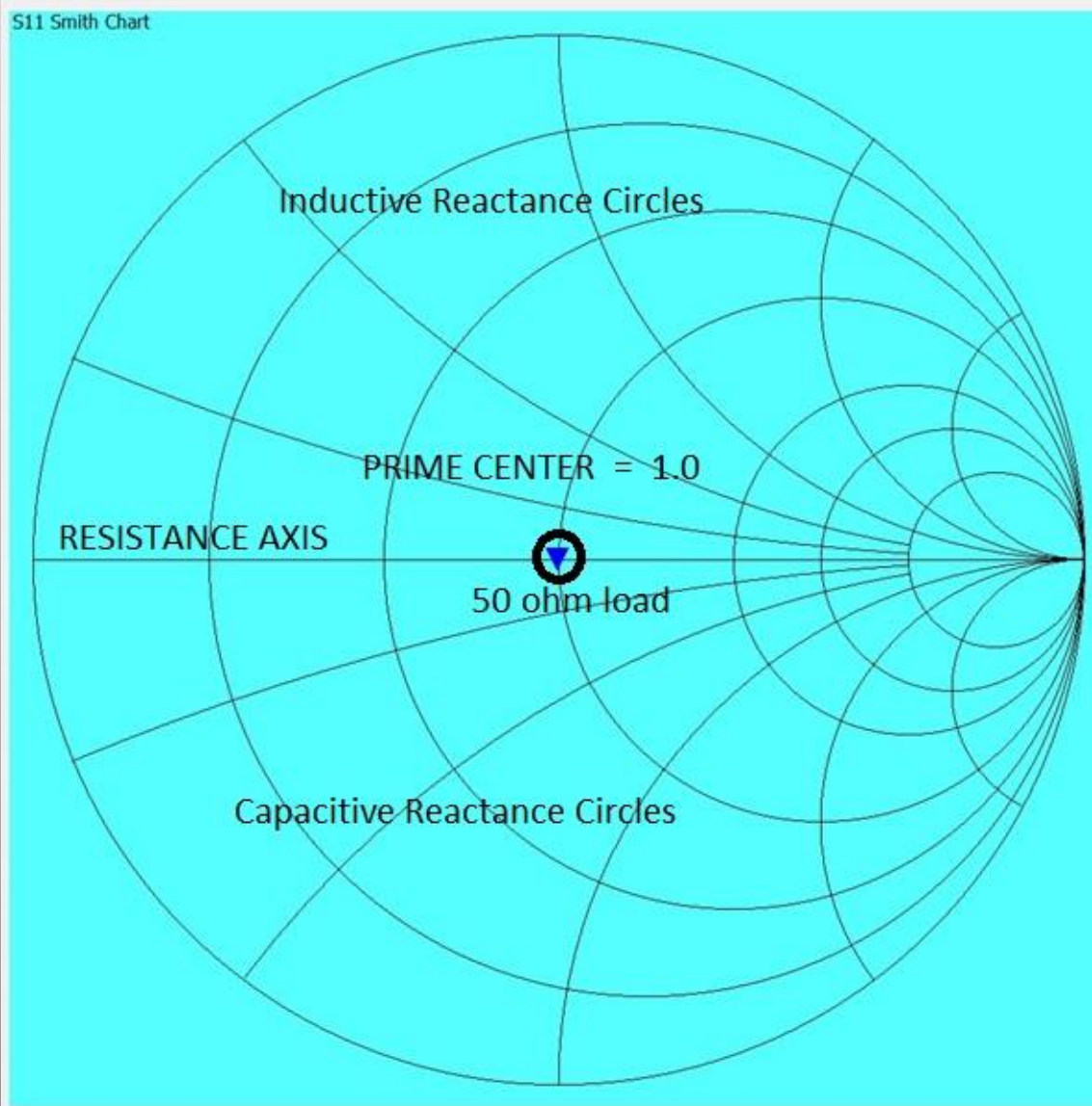

Measuring Antenna Characteristics

Resistance R (ohms)

Reactance X (ohms)

Impedance Z (ohms)

Phase θ (degrees)

Reflection Coefficient ρ rho

RETURN LOSS (dB)

SWR

Smith Chart Analysis

Even young kids know this
“Grampy, please push in phase with my natural swinging
to get me going higher”



What happens if Grampy pushes
too soon? too late?

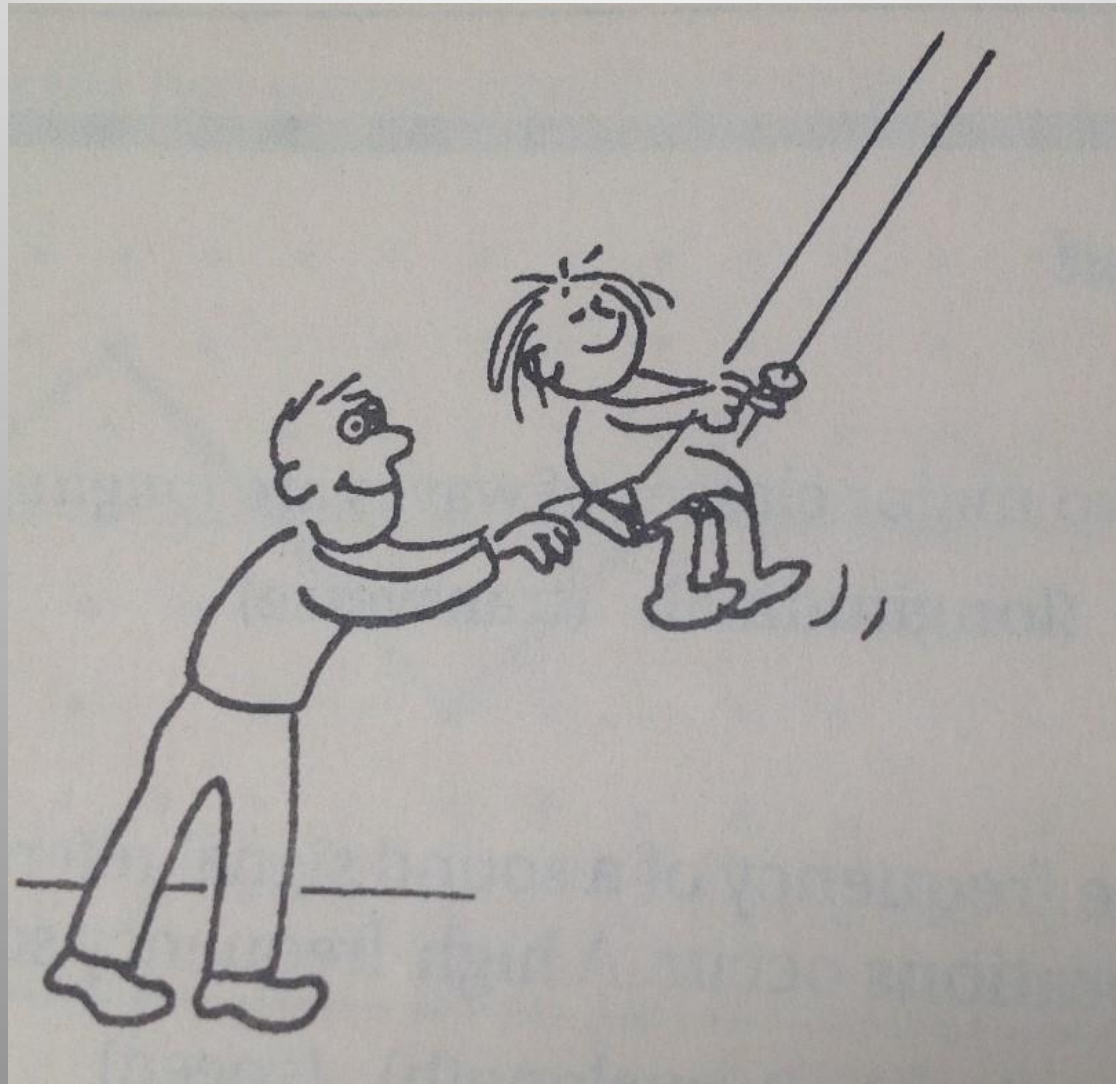

Antennas work the same way

The input “push” from the feed line needs to be in-phase with the natural vibrations of current in the antenna conductors

We call this “resonance”

Can the Nano VNA help set up your antenna?

You want the feed line to “push” the electrons back and forth in rhythm with the current in the antenna

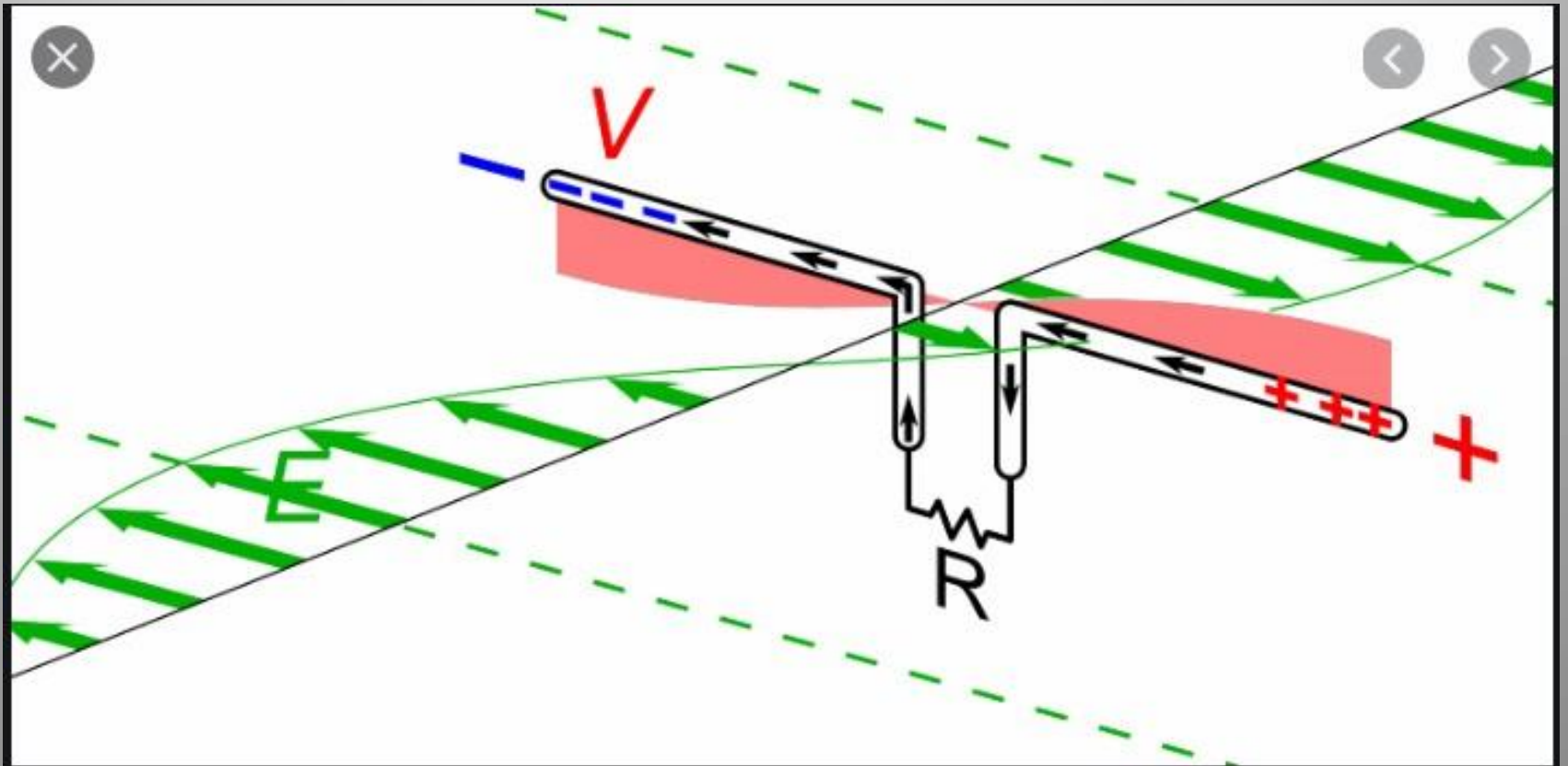

The charges at the ends of the antenna have reversed polarity in $\frac{1}{2}$ cycle of RF

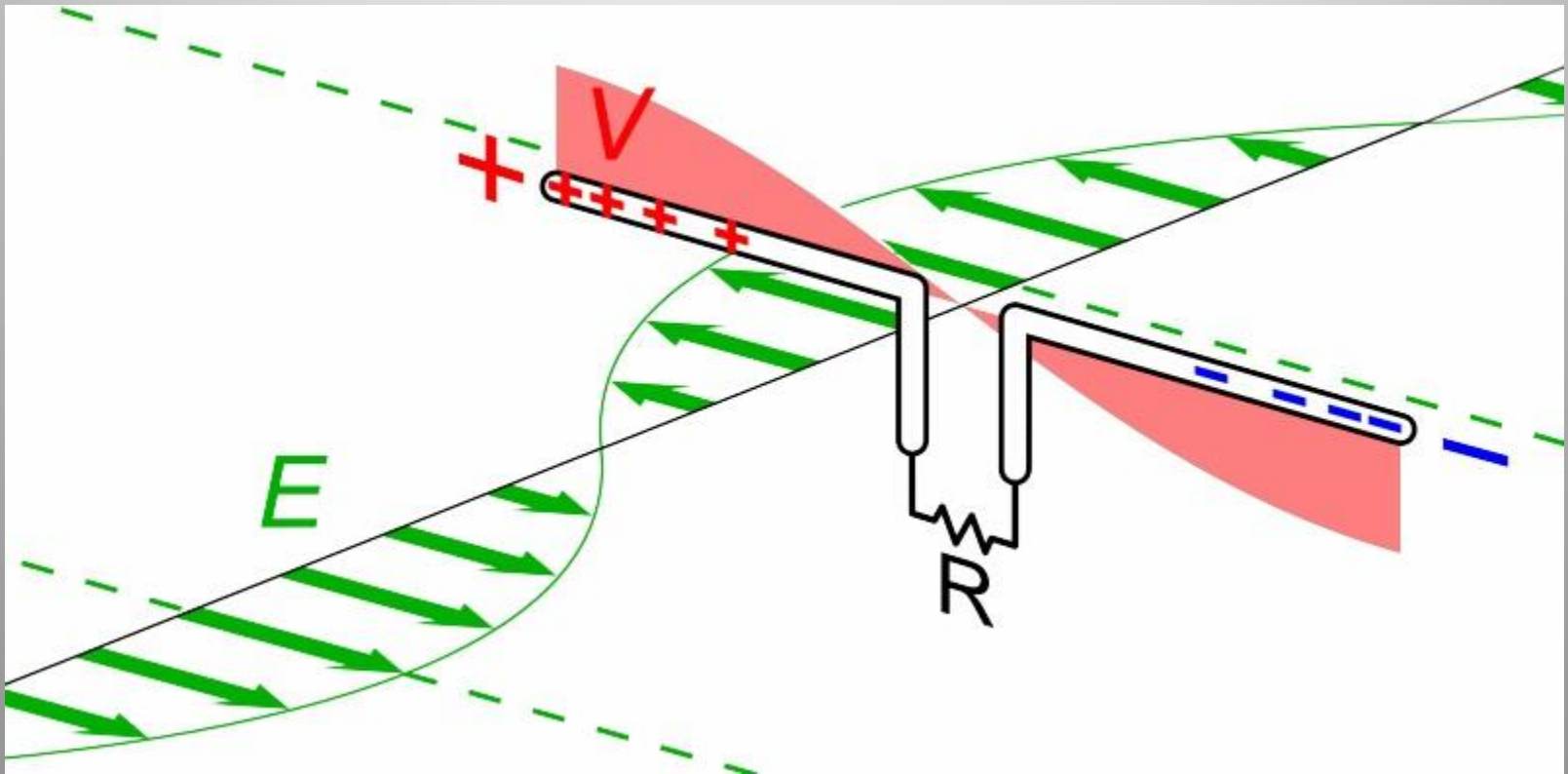

The RF wave λ must travel twice the dipole length in one RF cycle (period)

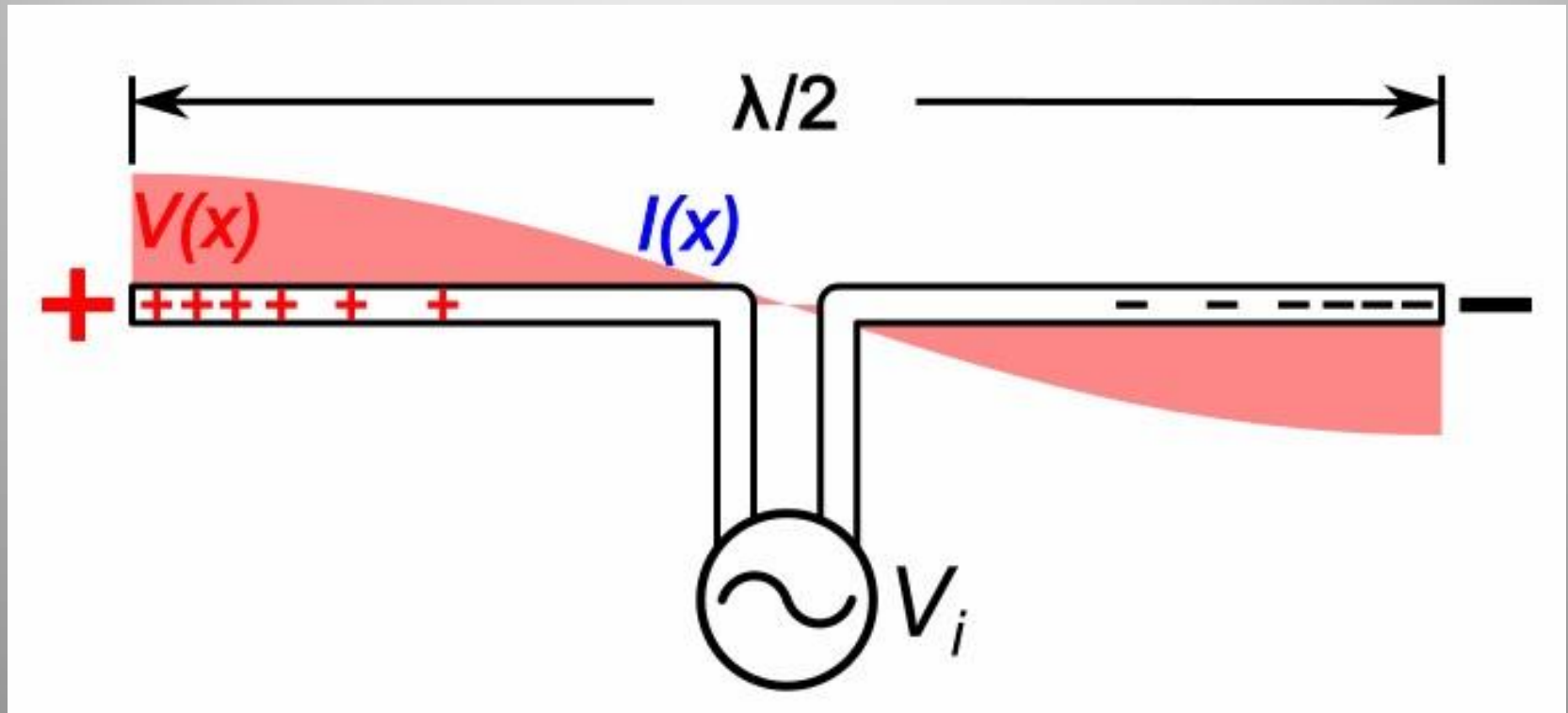

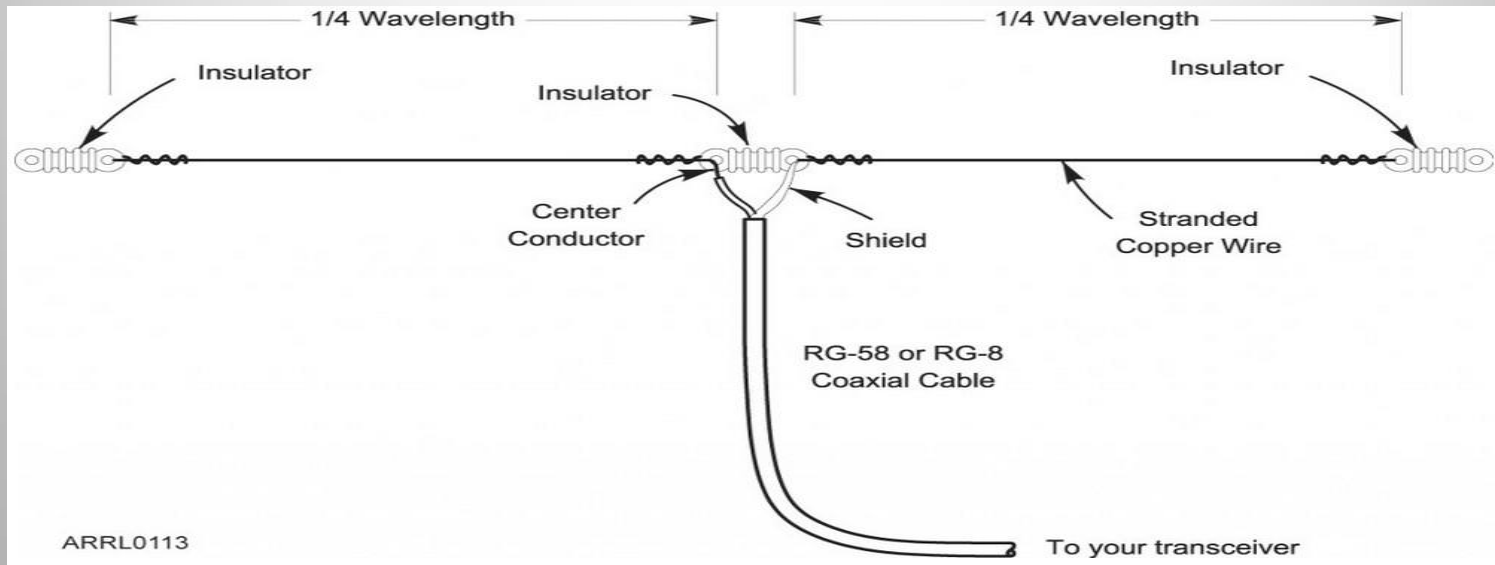

What is the lowest “resonant frequency”
of a dipole that is 130 feet long?

Resonant Frequency for 130 ft dipole

- 1) RF wave must travel 260 ft in one RF cycle λ
- 2) RF velocity in wire: V about 1 ft/nanosecond
- 3) Time for 1 RF cycle must be about 260 nanoseconds
- 4) 260×10^{-9} seconds = the PERIOD T of oscillation
- 5) Frequency = $1 / \text{period}$
- 6) Frequency = $1 / (260 \times 10^{-9} \text{ seconds})$

Lowest Resonant frequency 130 ft dipole = 3.8 MHz

This looks like an “end-fed” dipole

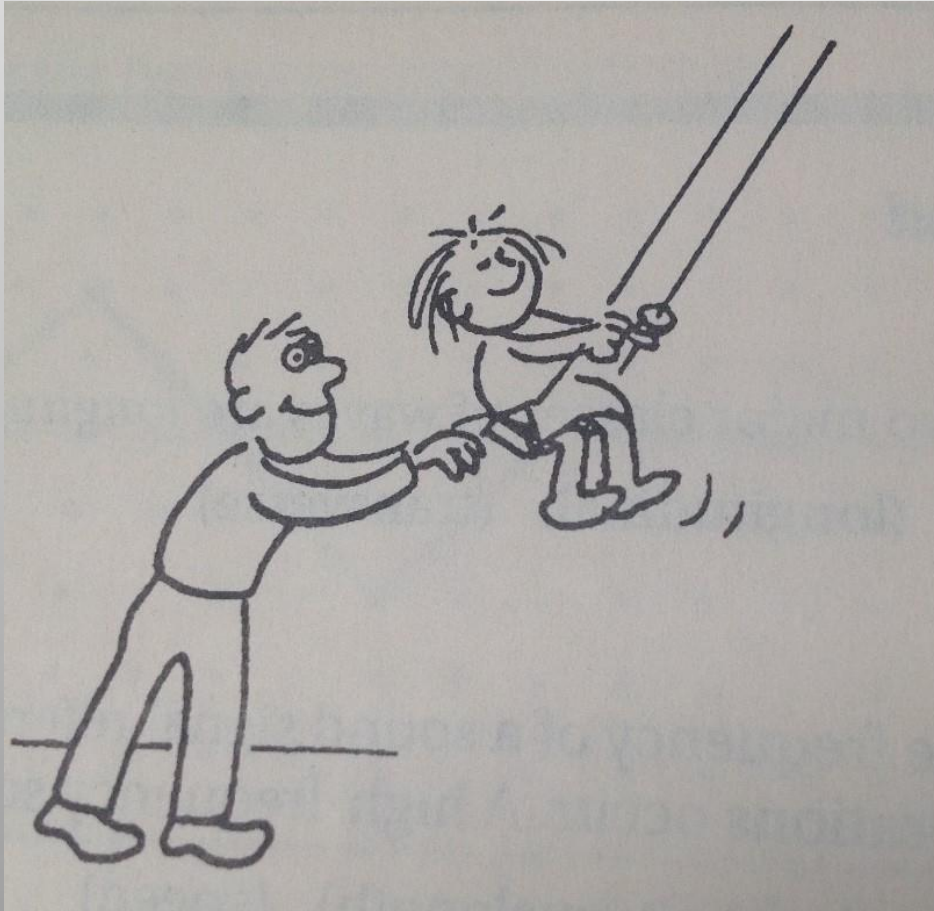

At resonance the current and the voltage are IN-PHASE at the feed line connection and maximum current occurs in the antenna

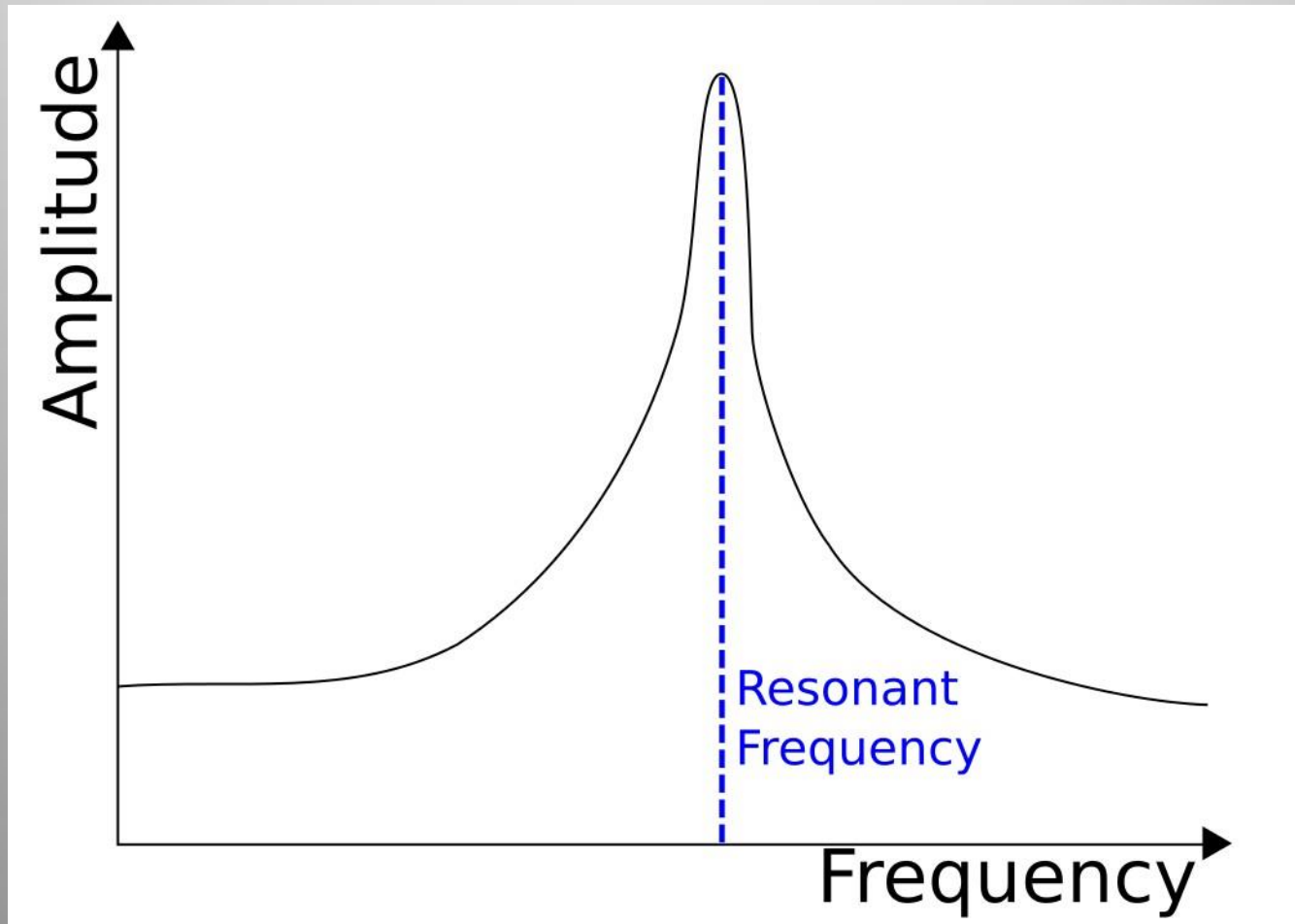

If you transmit on a frequency that is NOT RESONANT
SWR climbs, but WHY?

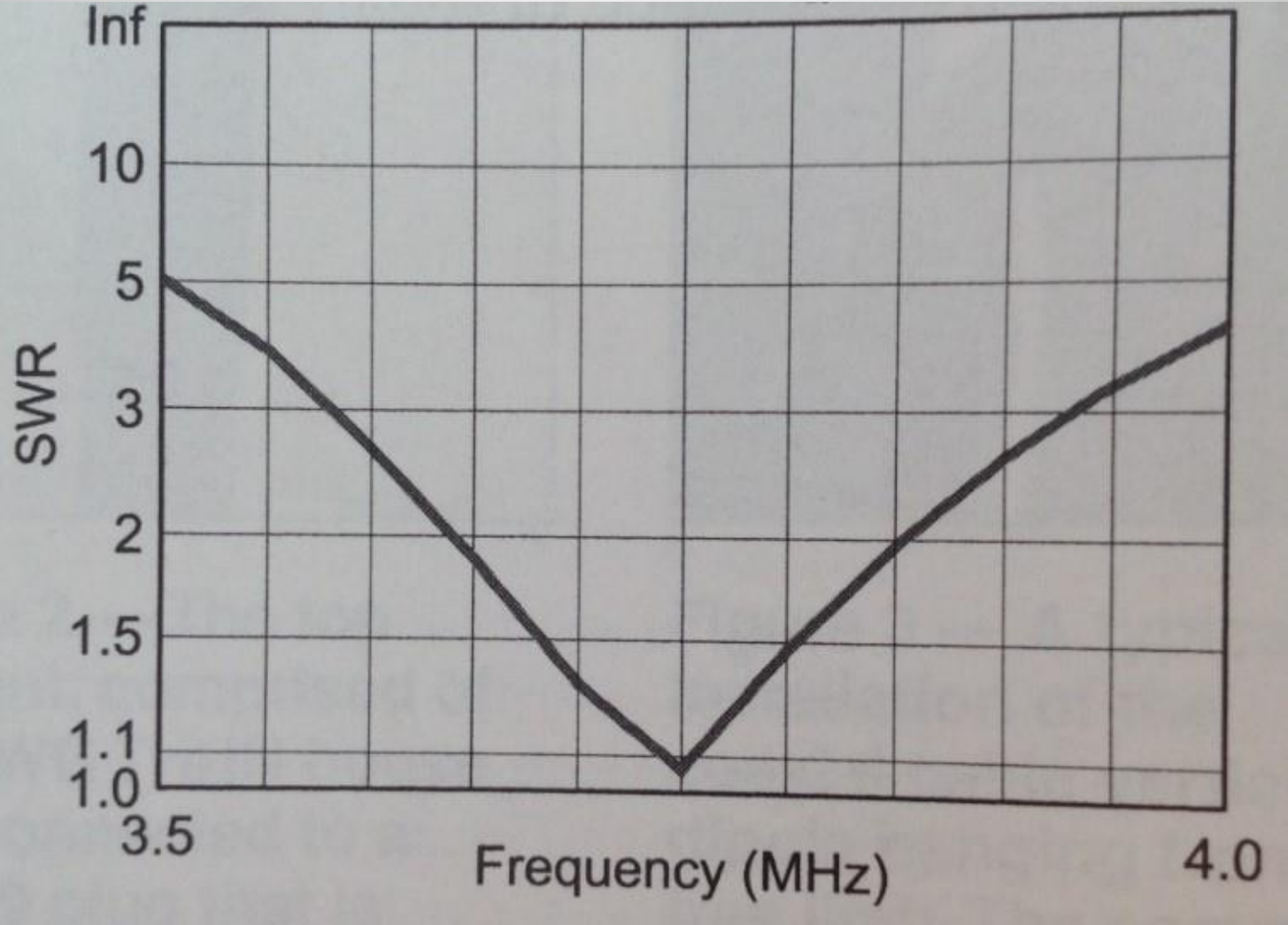

Maximum Power Transfer

Conjugate Match $Z(\text{load}) = Z^*(\text{feed line})$

Power Transfer Efficiency

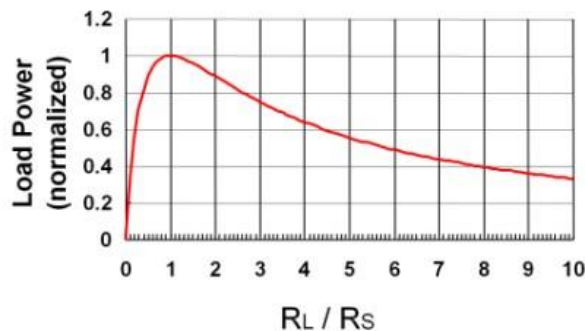
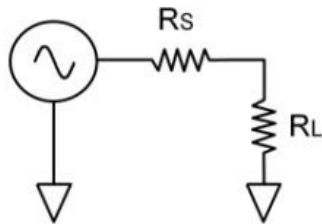

Maximum power is transferred when $R_L = R_s$

For complex impedances, maximum power transfer occurs when $Z_L = Z_s^*$ (conjugate match)

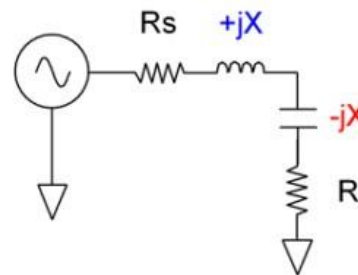

Off resonance a dipole now shows
REACTANCE (phase errors)
and behaves like a series **RLC** circuit

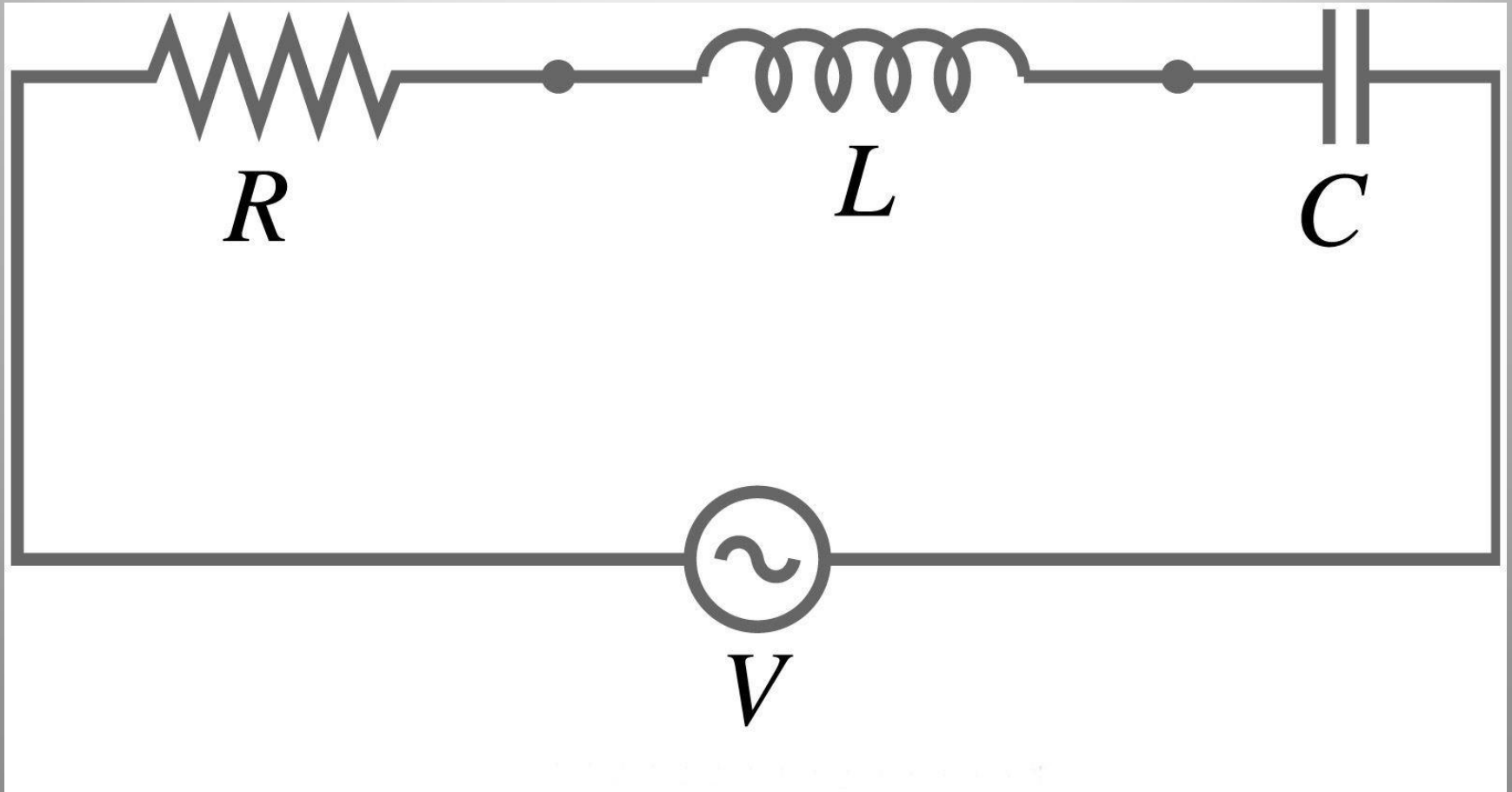

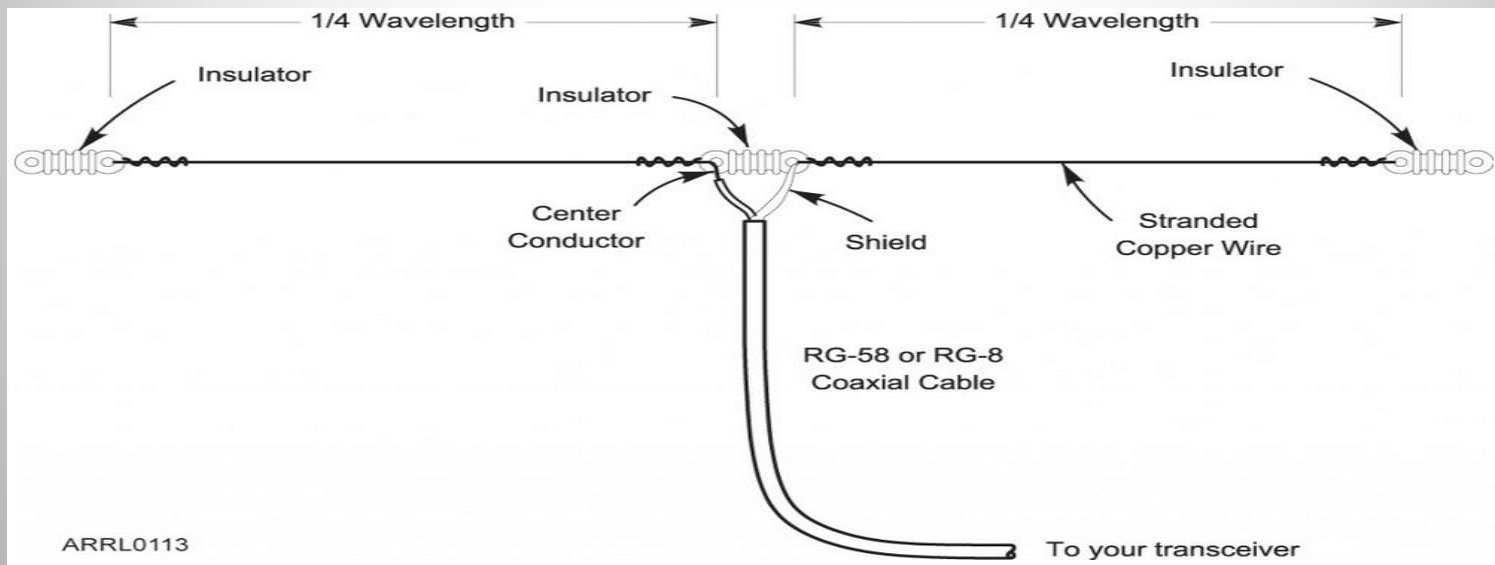

- Below resonance: the dipole is too short and the current leads the driving voltage (capacitive reactance)
- Above resonance: the dipole is too long, and the current lags the driving voltage (inductive reactance)

ELI the ICE man

SWR climbs off resonance due to big changes in REACTANCE

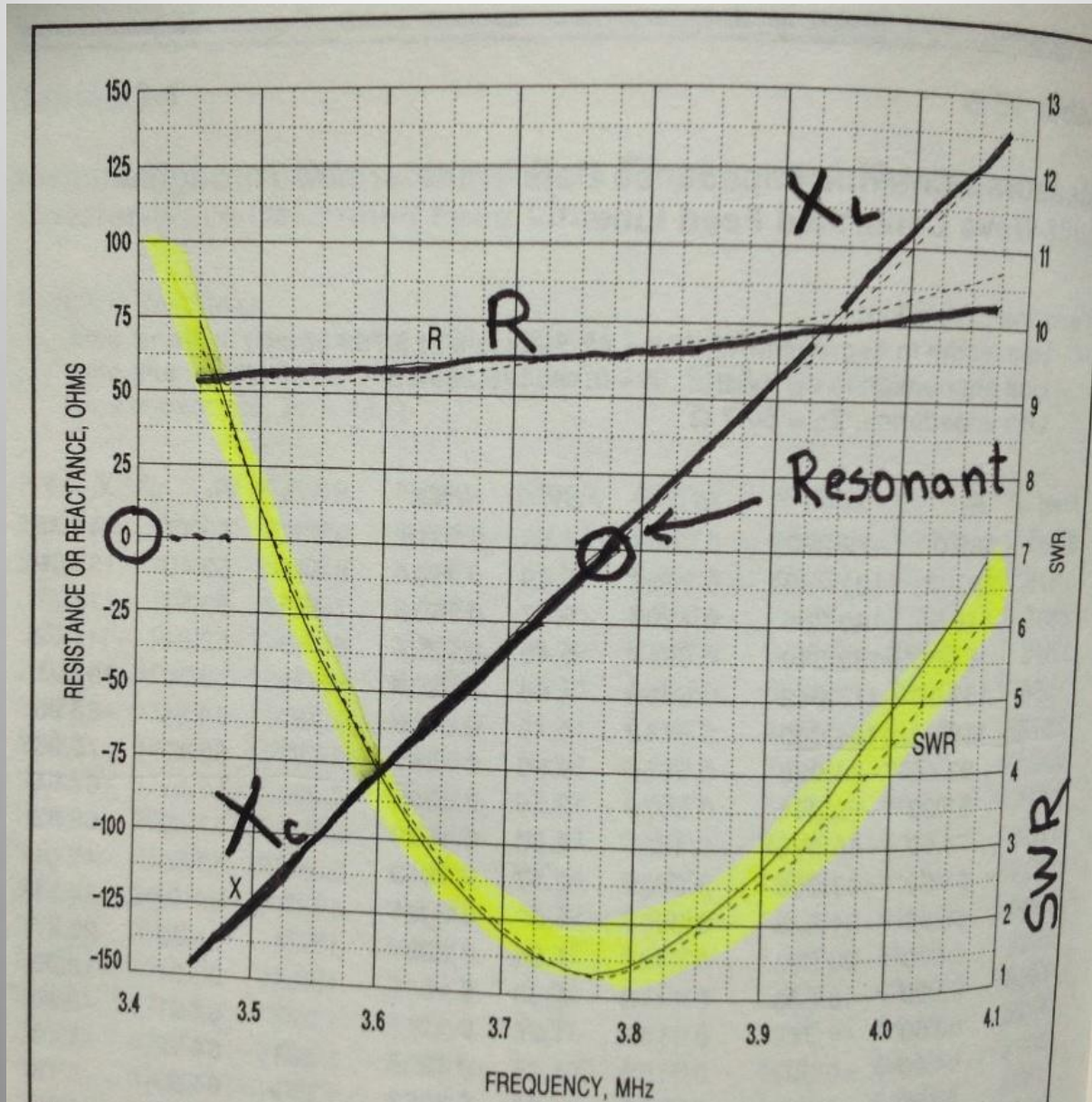

How do you get rid of “reactance”?
Take down antenna and change length of dipole?

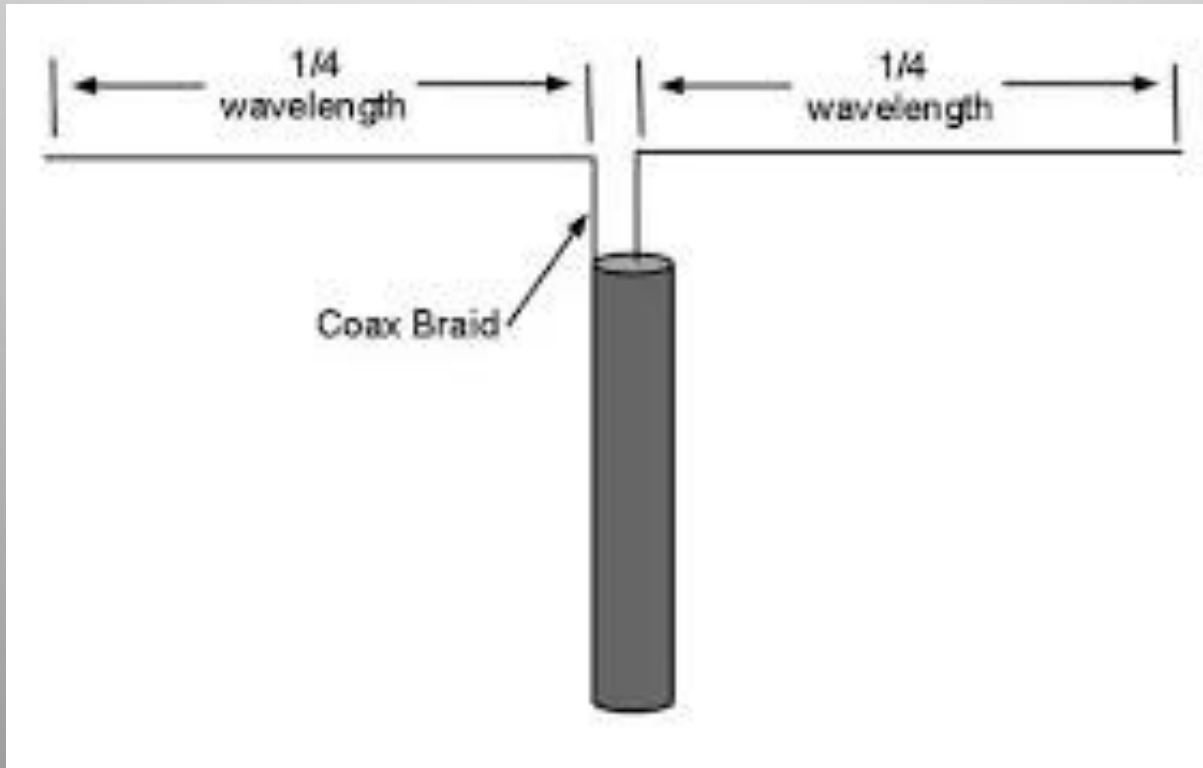

**Resonance will make your grandkids happy
so **CANCEL** that **REACTANCE** in your shack!**

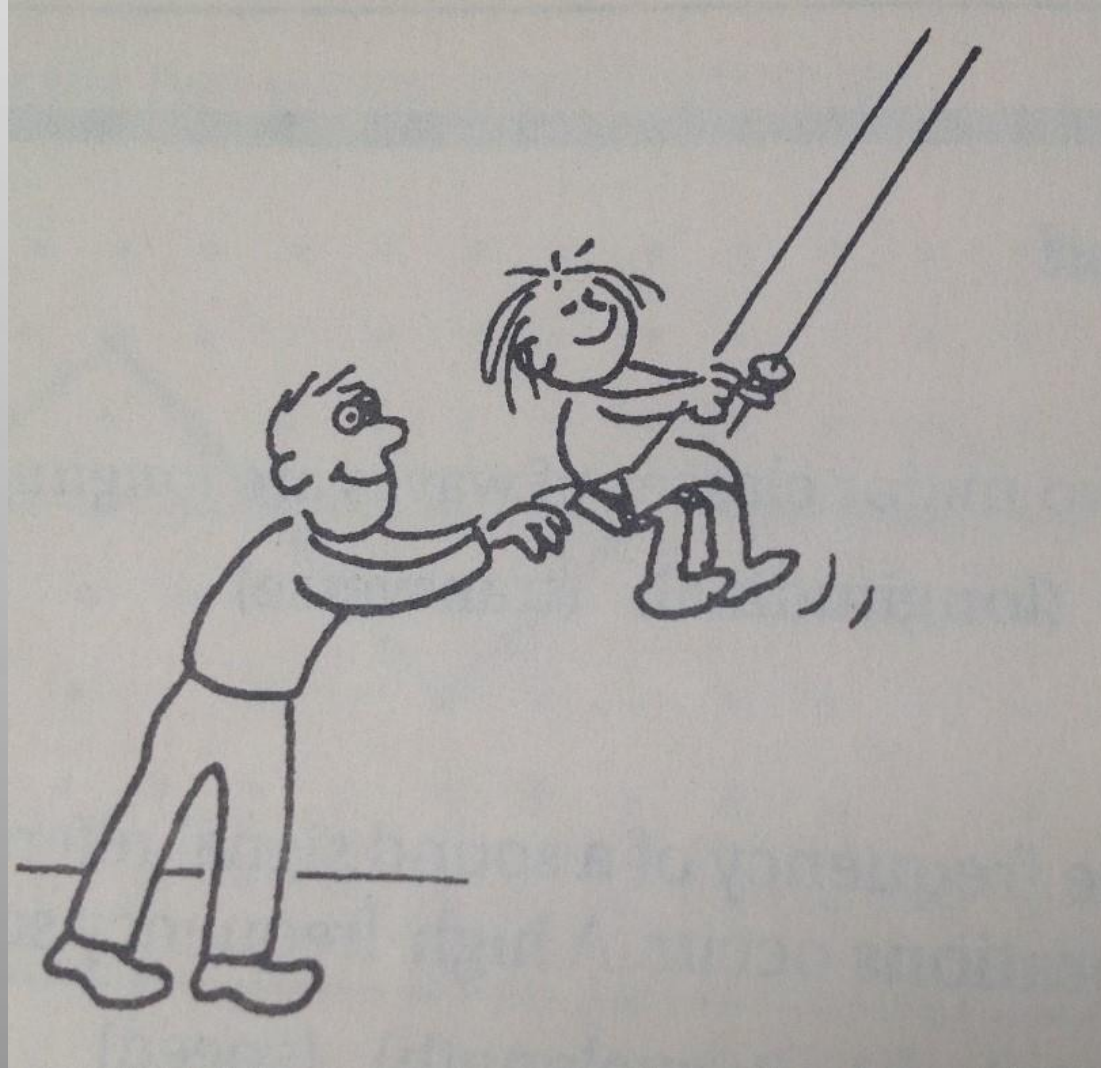

But does the **antenna itself** need to be **resonant** to work well?

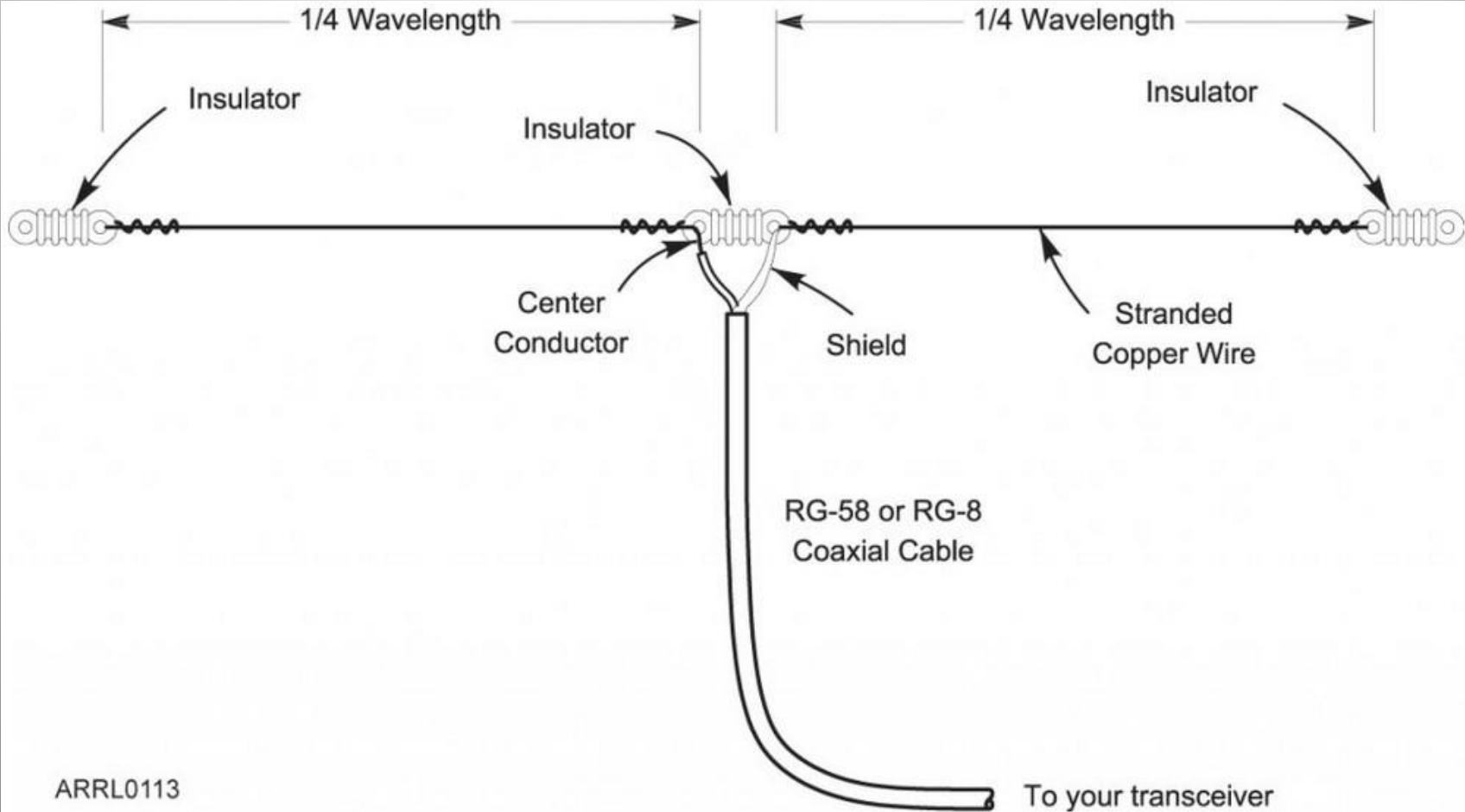

This “random” length non-resonant wire can work well on many HF frequencies with some help from an antenna “tuner”
What exactly is the antenna tuner “tuning”?

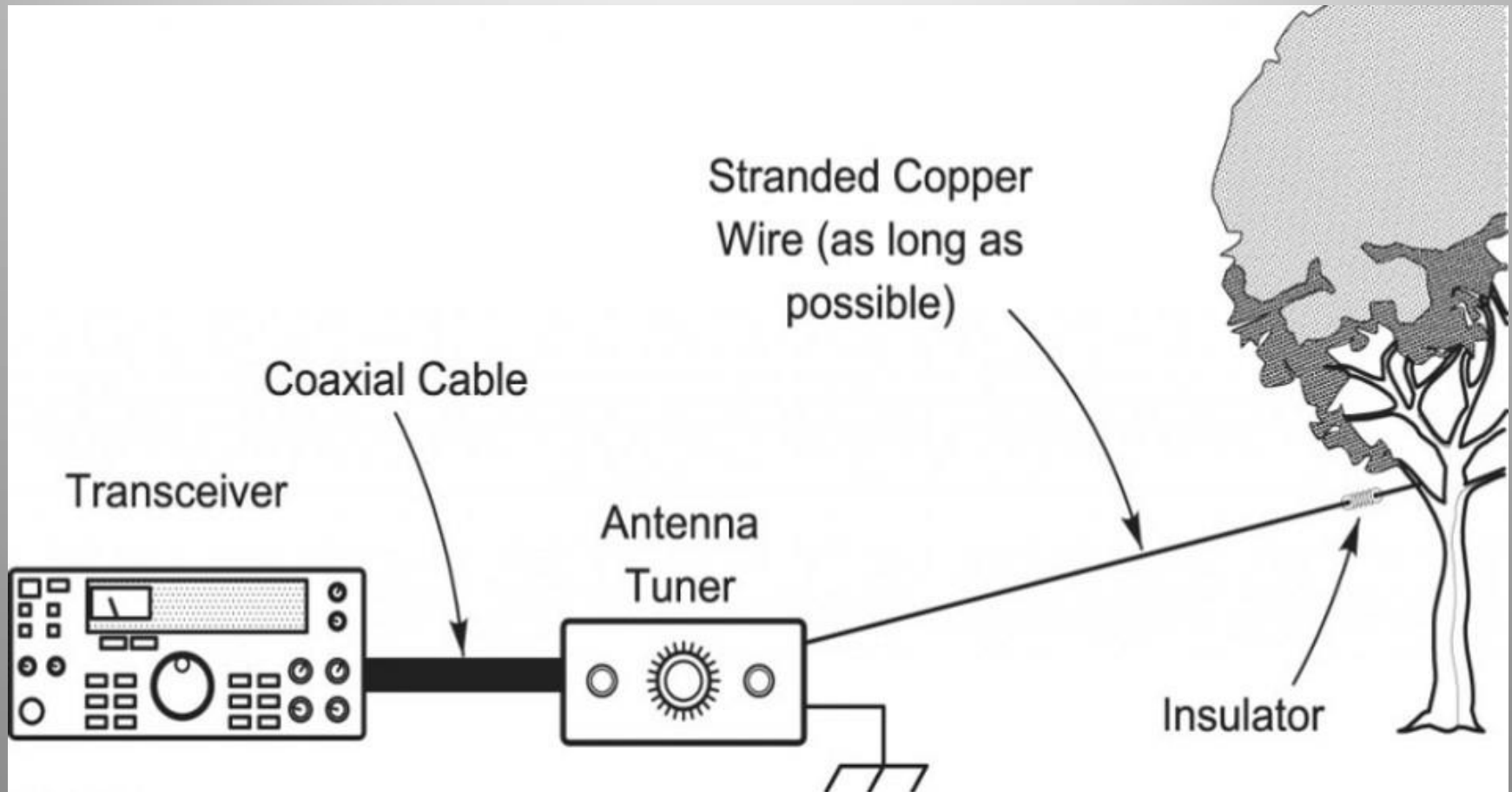

**130 ft Center Fed dipole with
Low-Loss BALANCED Ladder Line
can work on all HF bands with TUNER in the shack
WHERE is the SWR low in this image?**

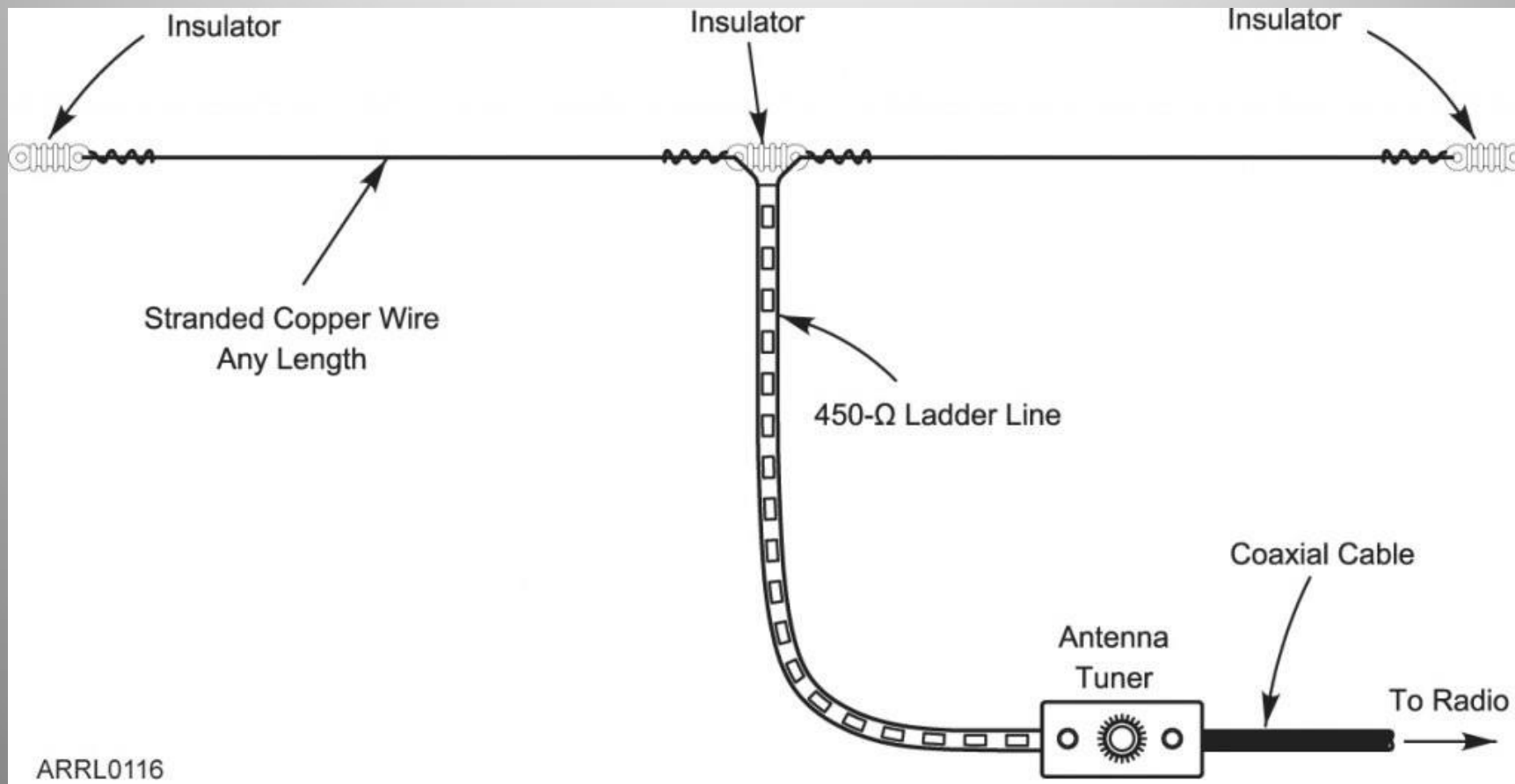

Tune out the REACTANCE in the shack by introducing a “conjugate impedance” in your antenna tuner

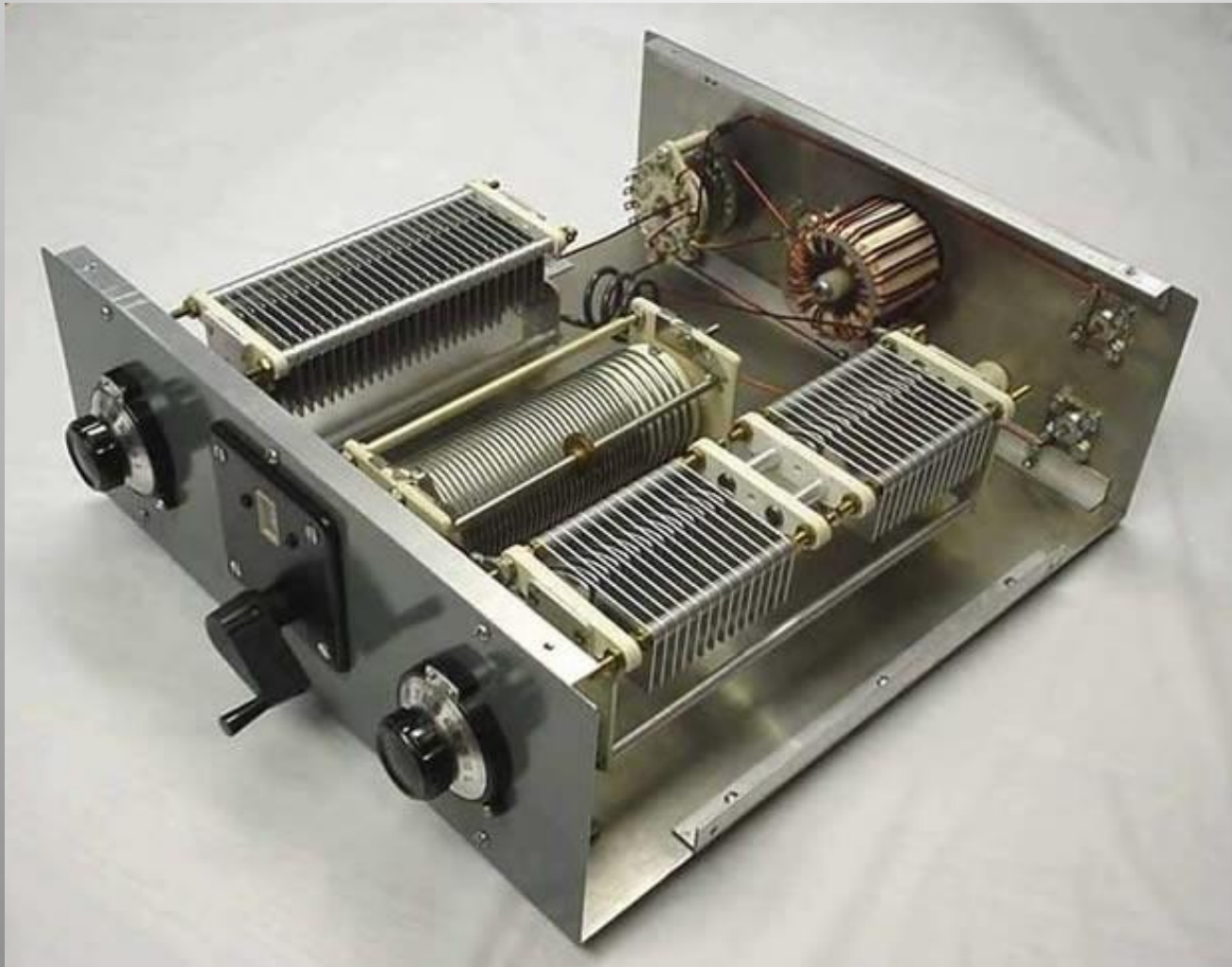

Impedance Matching Schemes

the common L network

Impedance Matching

- We want to match R_P to R_S and cancel reactances with a conjugate match.

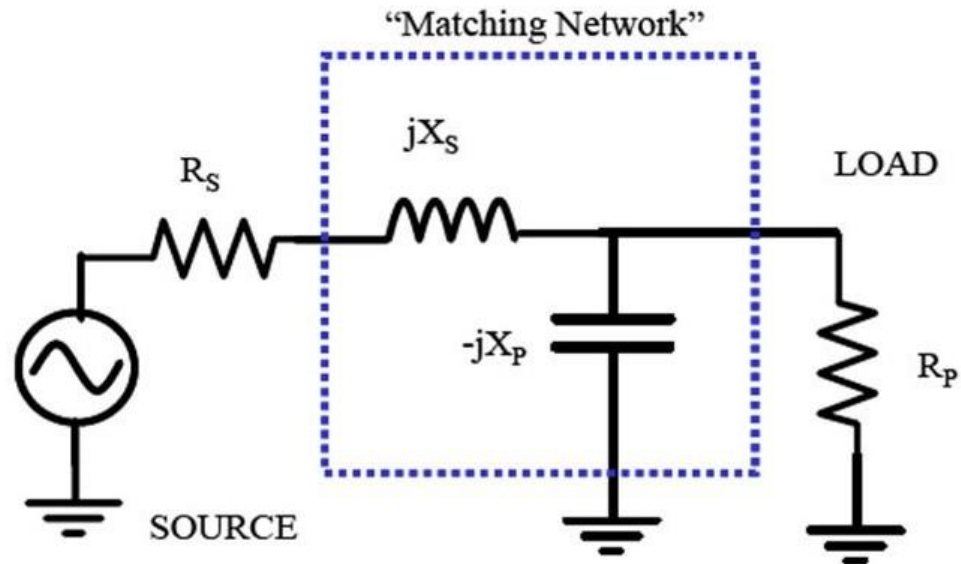

Let's put the Nano VNA to work testing real antennas
S11 = Signal goes out Ch0 and returns to same port

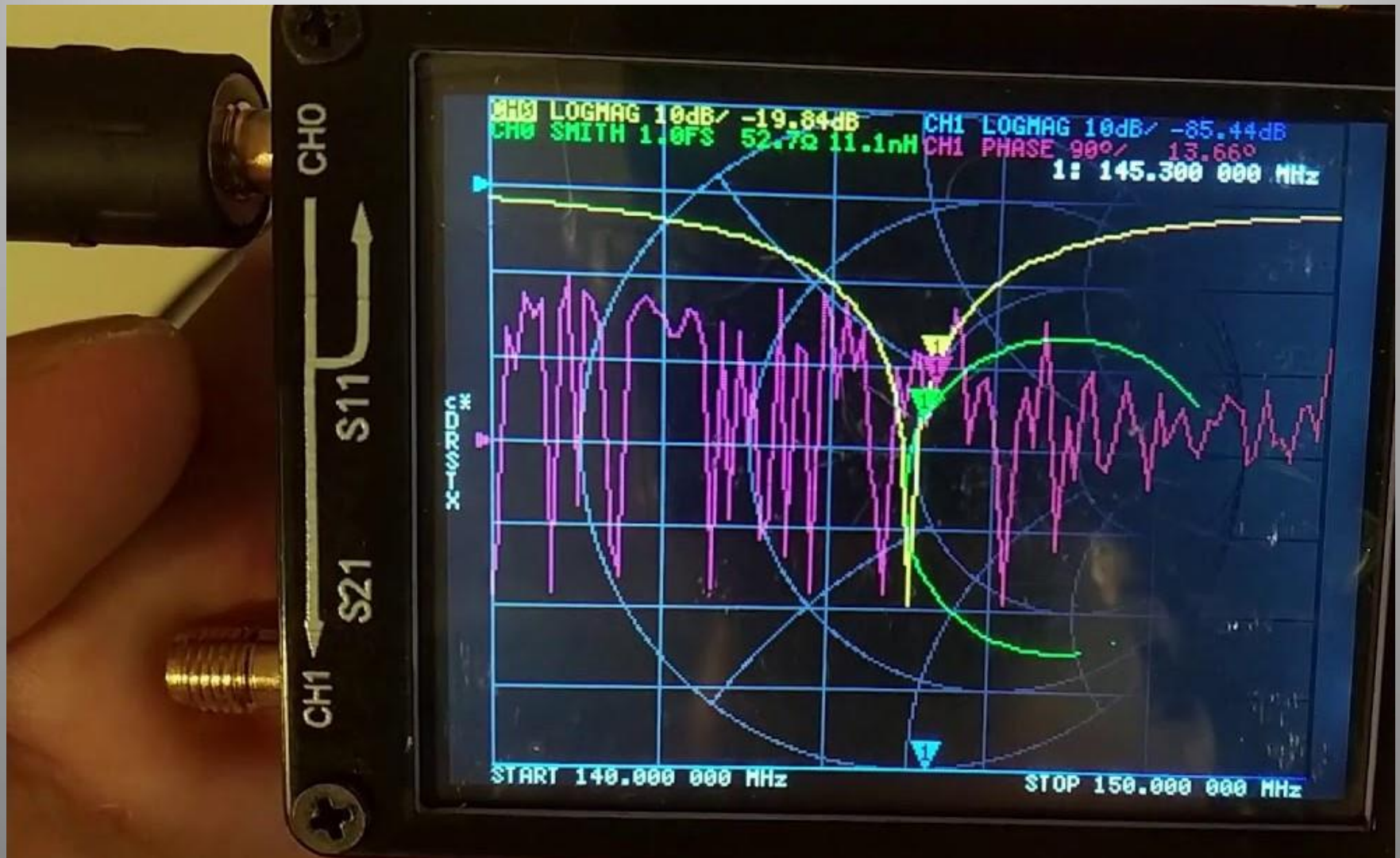

REFLECTION Parameters (Agilent Tech great resource)

Reflection Parameters

Reflection Coefficient $\Gamma = \frac{V_{\text{reflected}}}{V_{\text{incident}}} = \rho \angle \Phi = \frac{Z_L - Z_o}{Z_L + Z_o}$

Return loss = $-20 \log(\rho)$, $\rho = |\Gamma|$

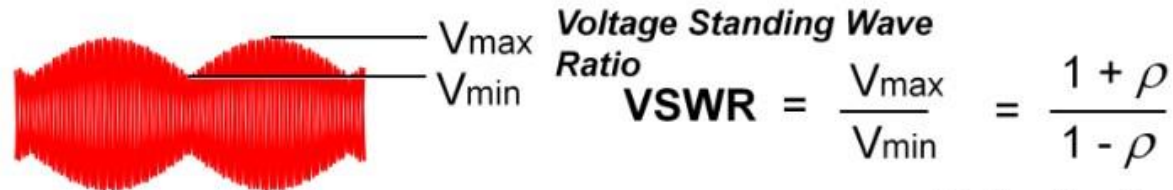

No reflection
($Z_L = Z_o$)

Full reflection
($Z_L = \text{open, short}$)

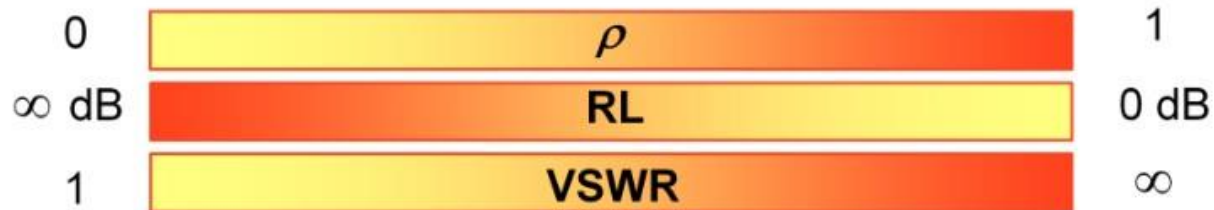

Let's check out some of the
antennas at K3EUI QTH

We are measuring the HF signals
returning to shack after

100 -150 ft

RG213 50-ohm coax

135 feet 80 meter Inverted V antenna
fed with 100 ft RG213 and W2DU current balun
On what frequencies is this antenna “resonant”?

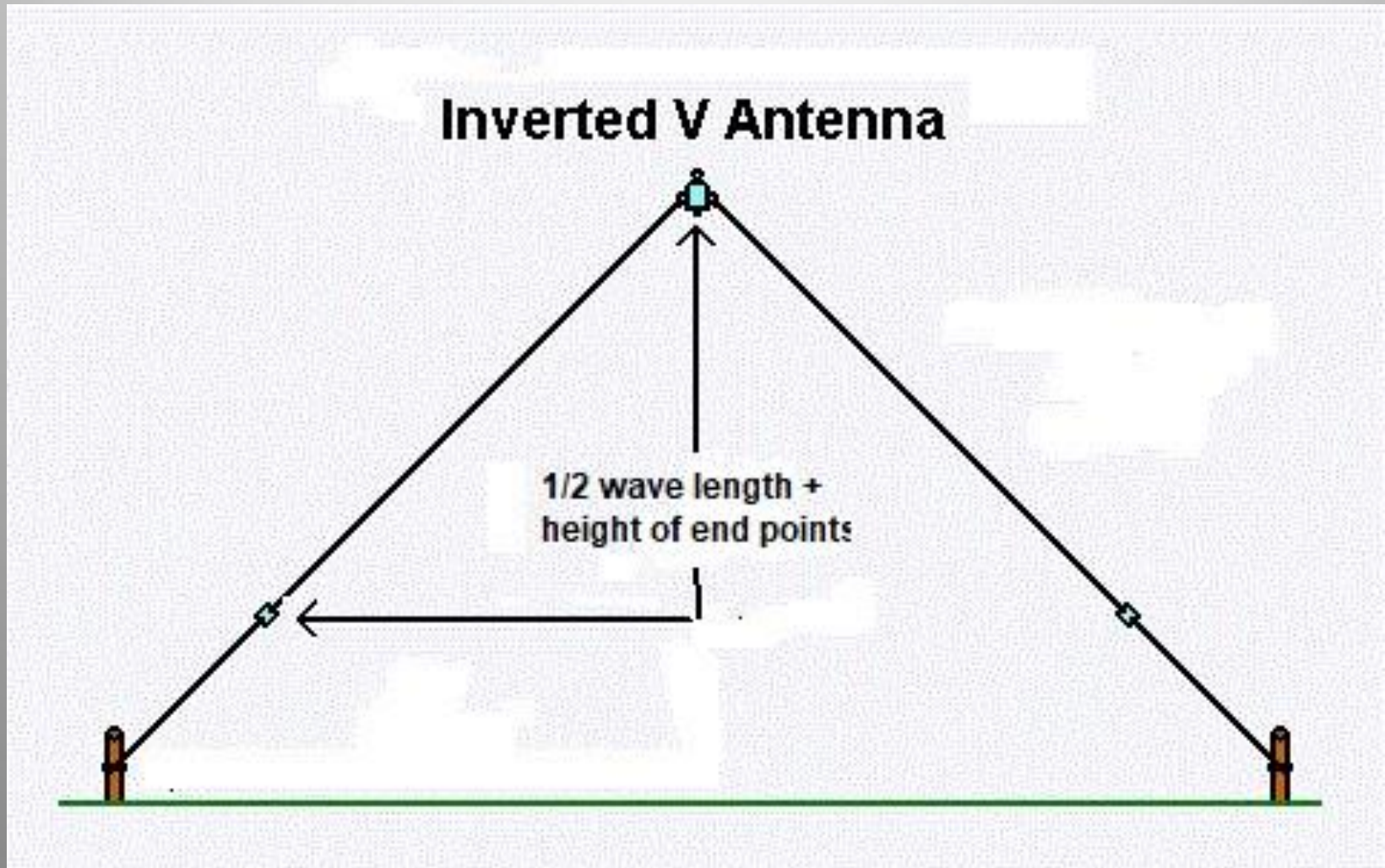

SWR plot: 135 ft center-fed dipole (3 – 30 MHz) ?

Note resonant “harmonics” are not in a ham band

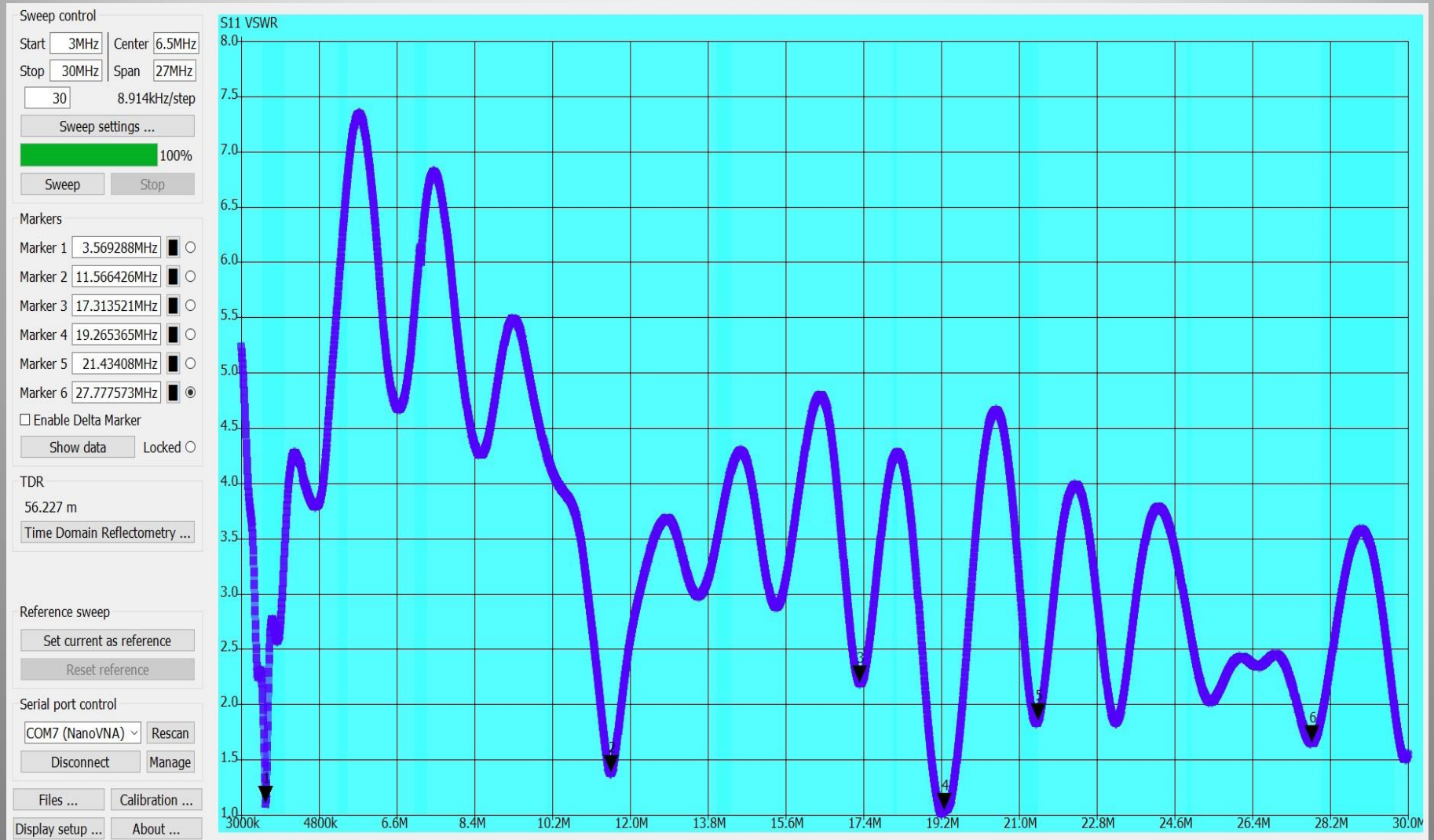

RETURN LOSS (dB) plot: 135 ft center-fed dipole shows the resonant frequencies more sharply than SWR

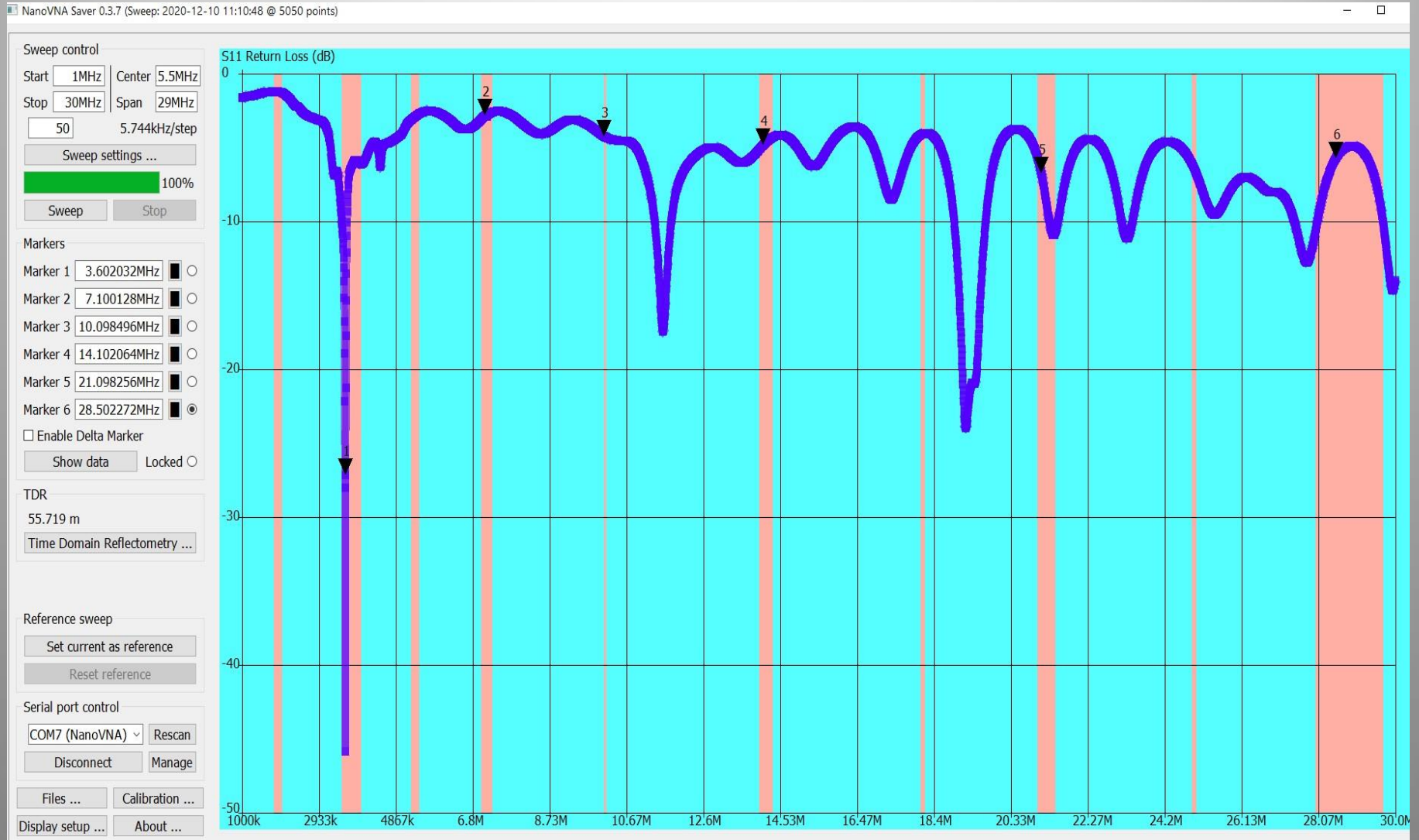

Smith Chart tells you everything you want to know

Where is the lowest SWR on the band?

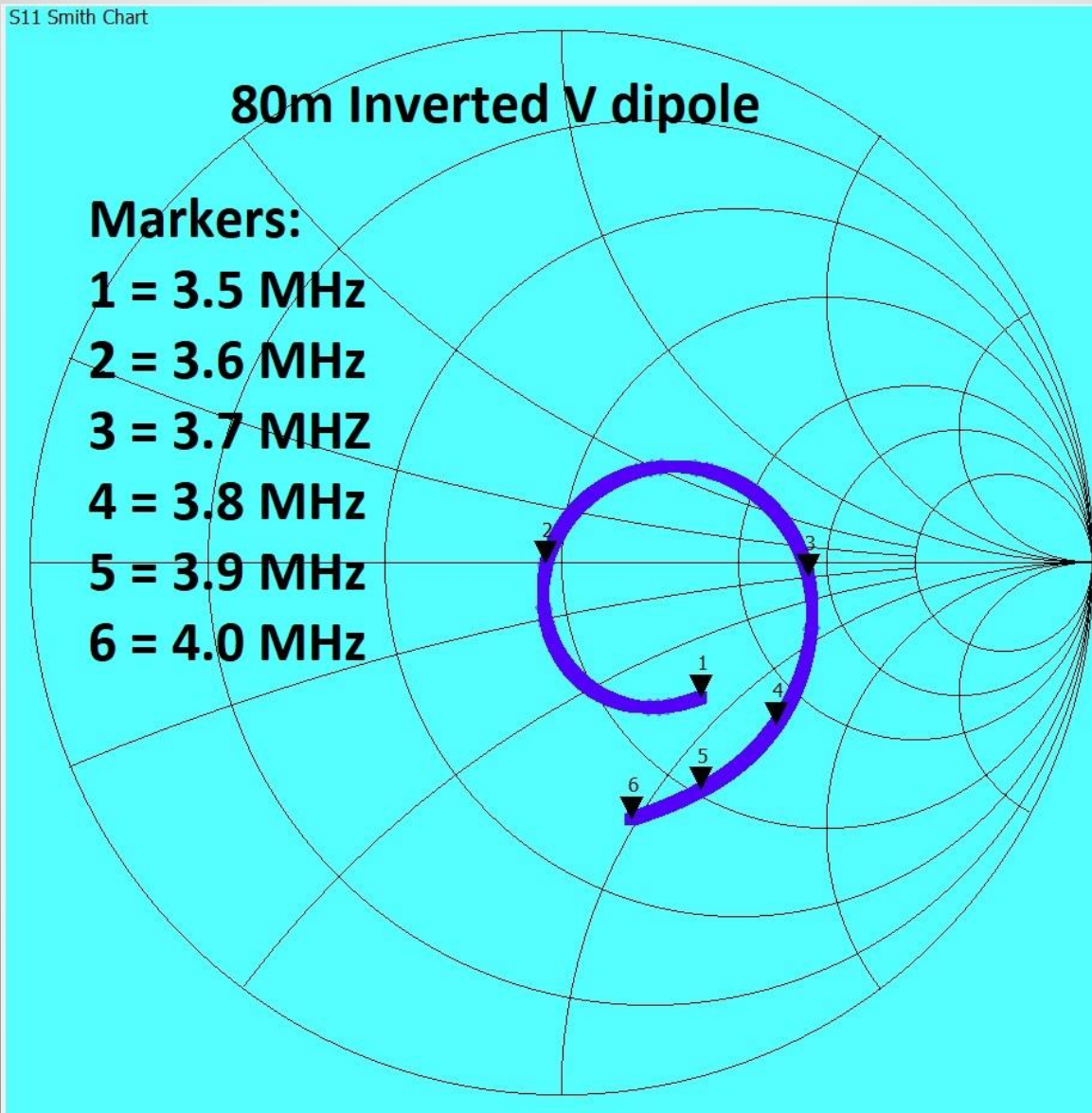

Resonance (3600 kHz) is easy to spot on this PHASE PLOT

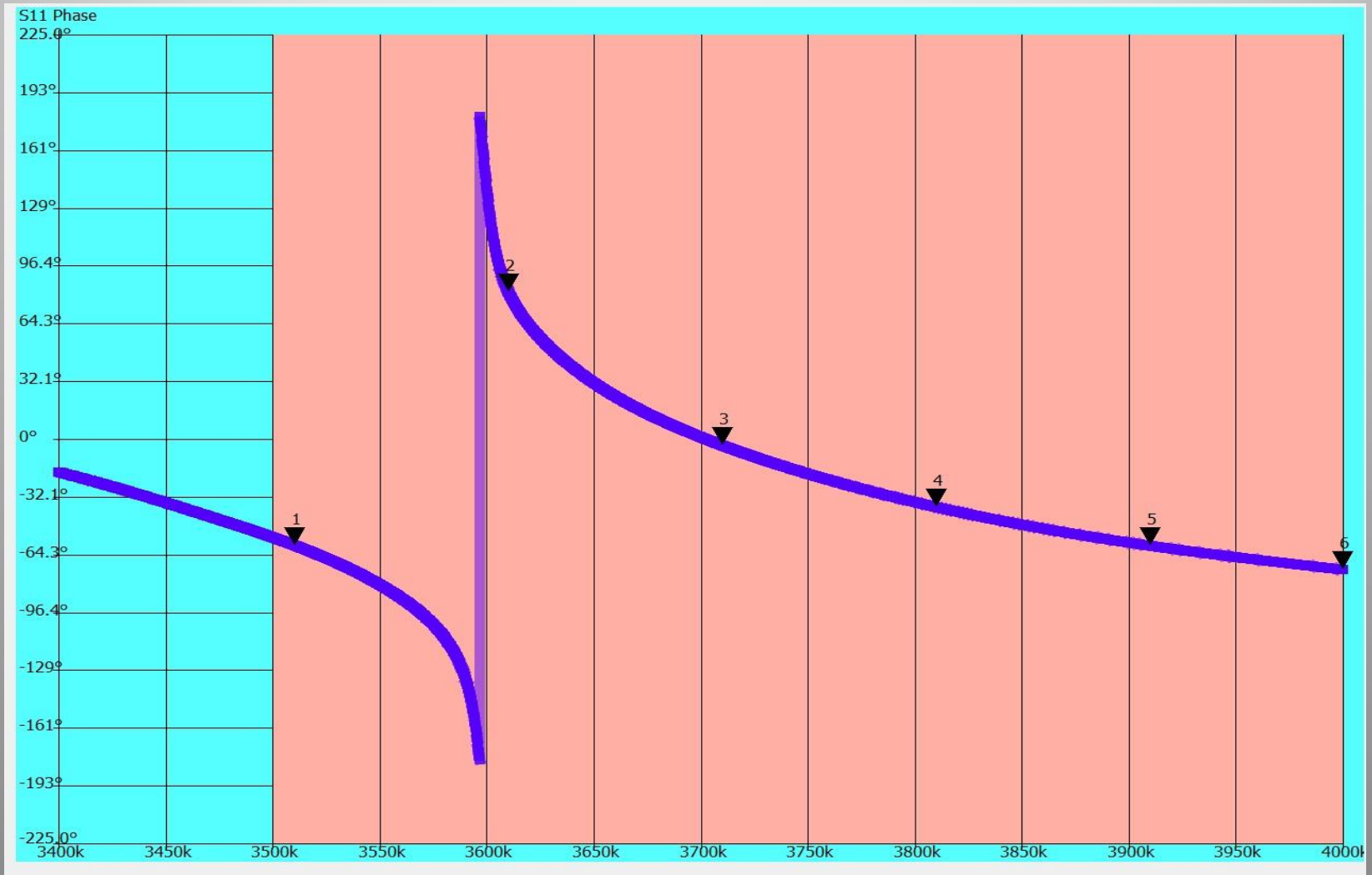

80m Inverted V antenna: all 6 graphs

At what frequencies will this antenna work best?

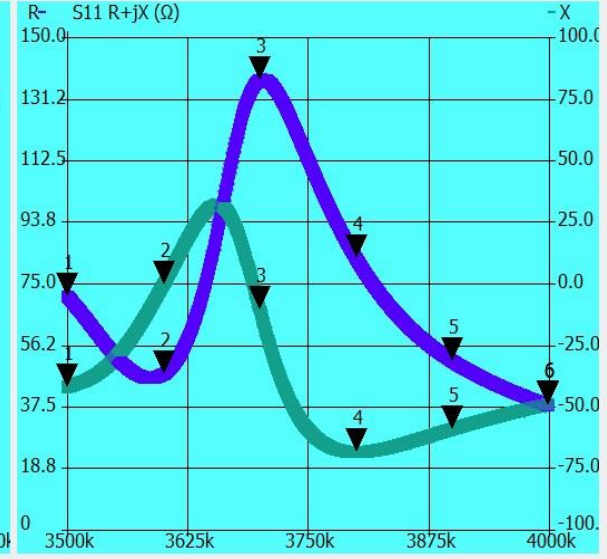
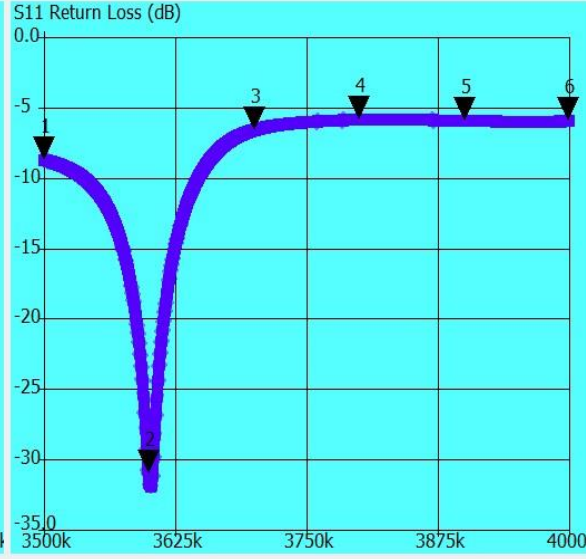
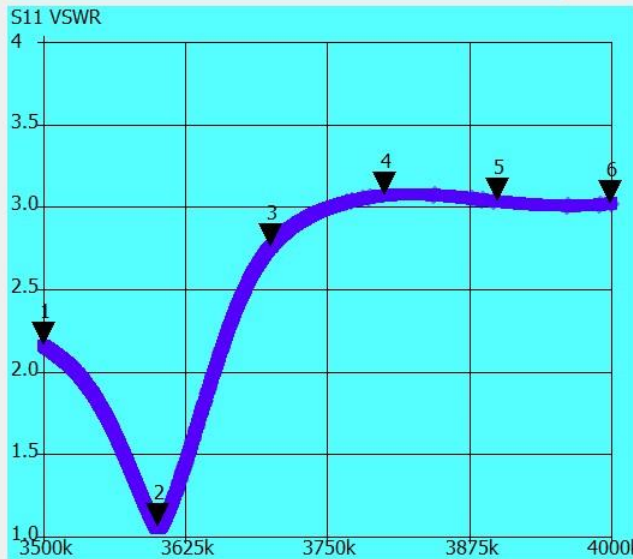
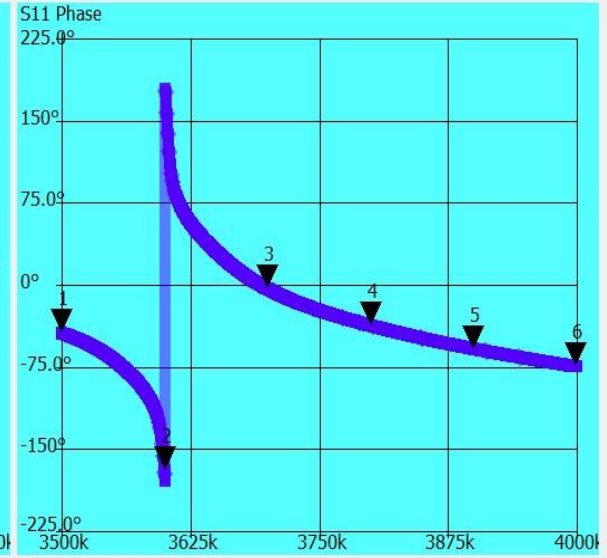
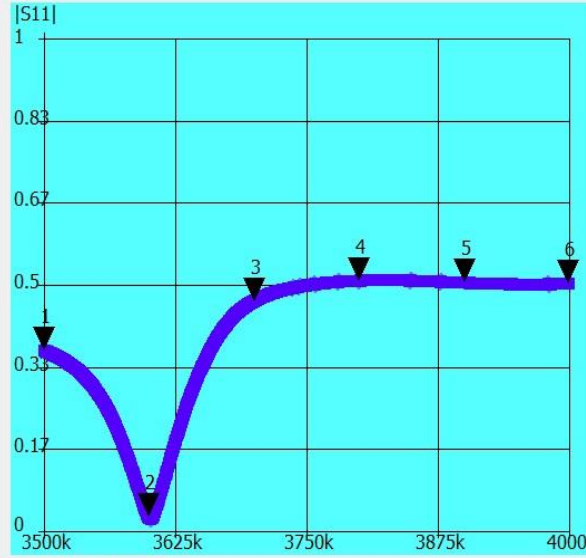
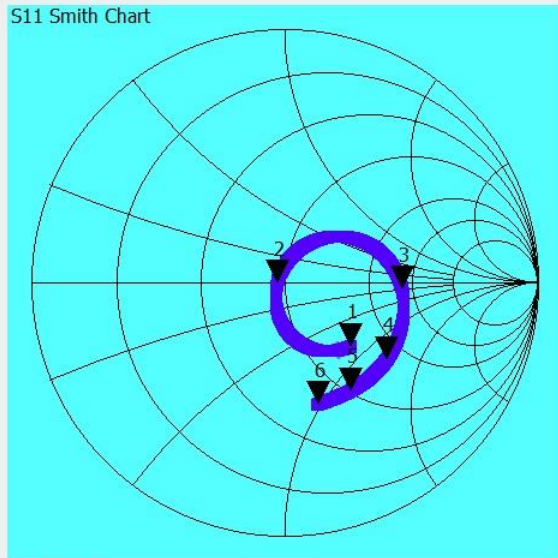

Can I QSY to 3990 kHz portion of PHONE band (SWR = 3:1)

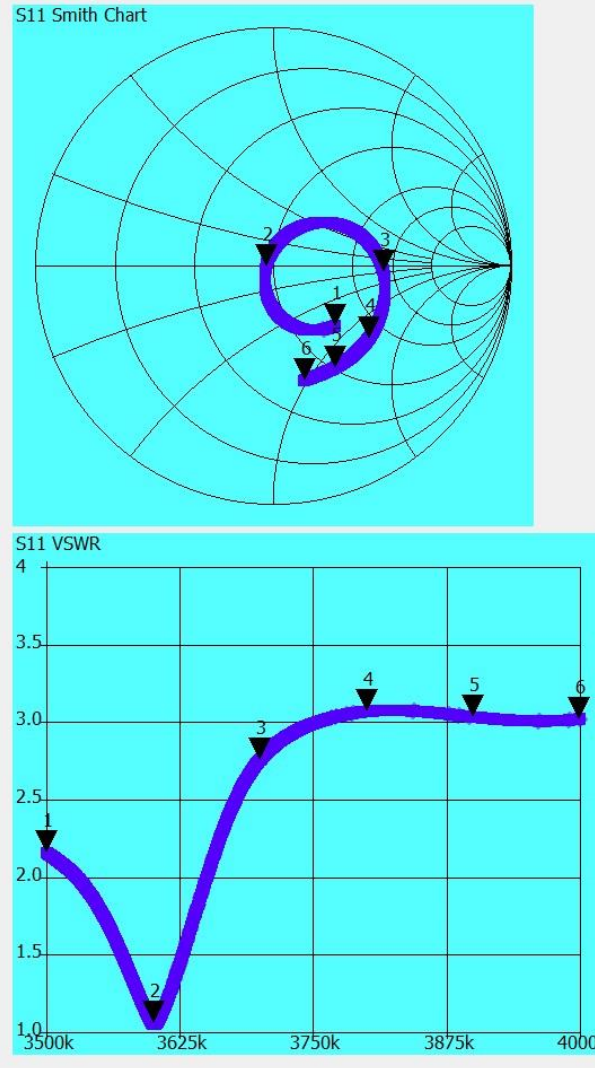

Introduce an “antenna tuner” in the shack
How does this work?



Same 80m antenna but now tuned to 3990 kHz (PHONE) by an antenna tuner in the shack

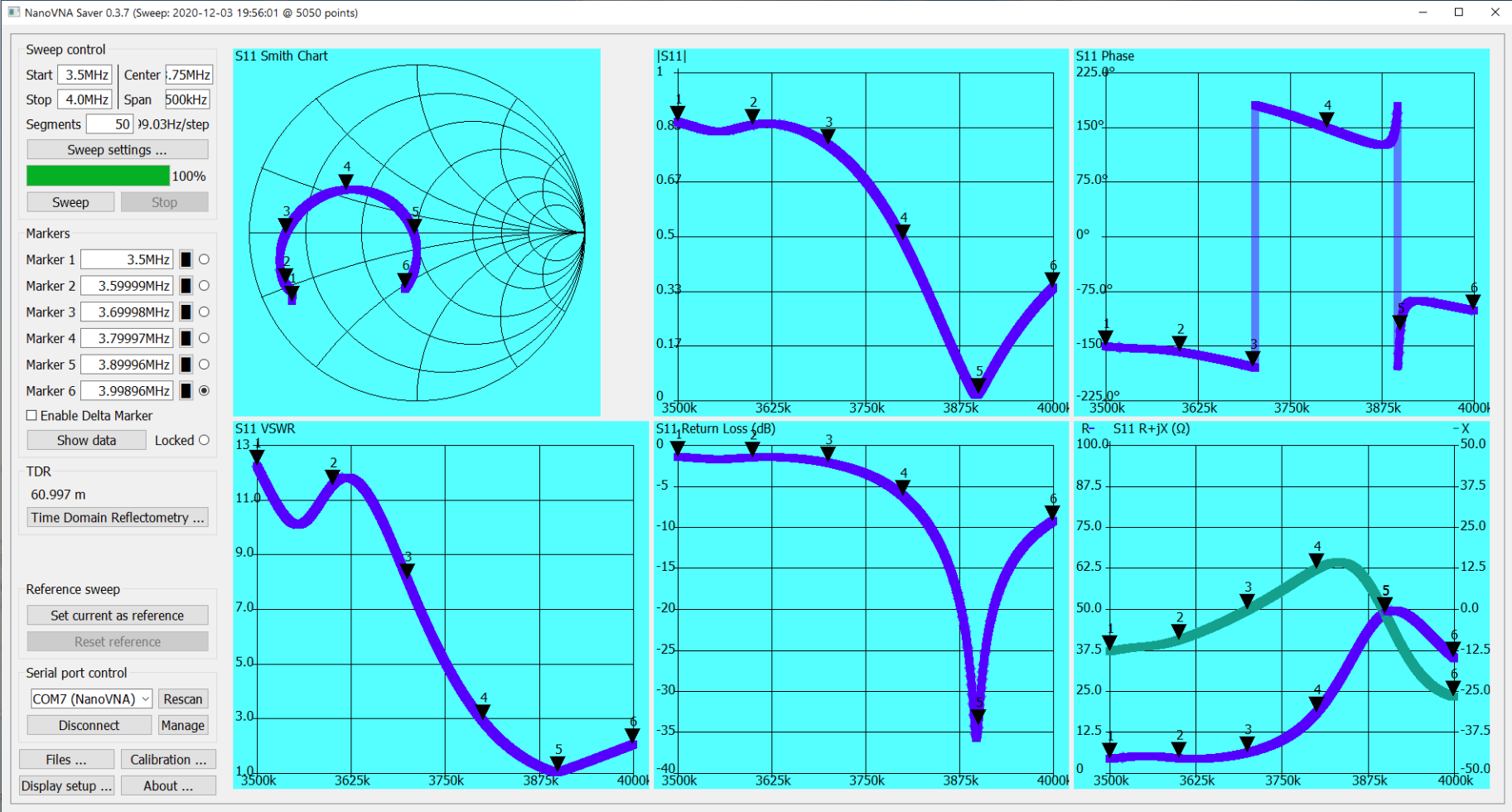

How might a two-band 80/40m TRAP dipole behave?

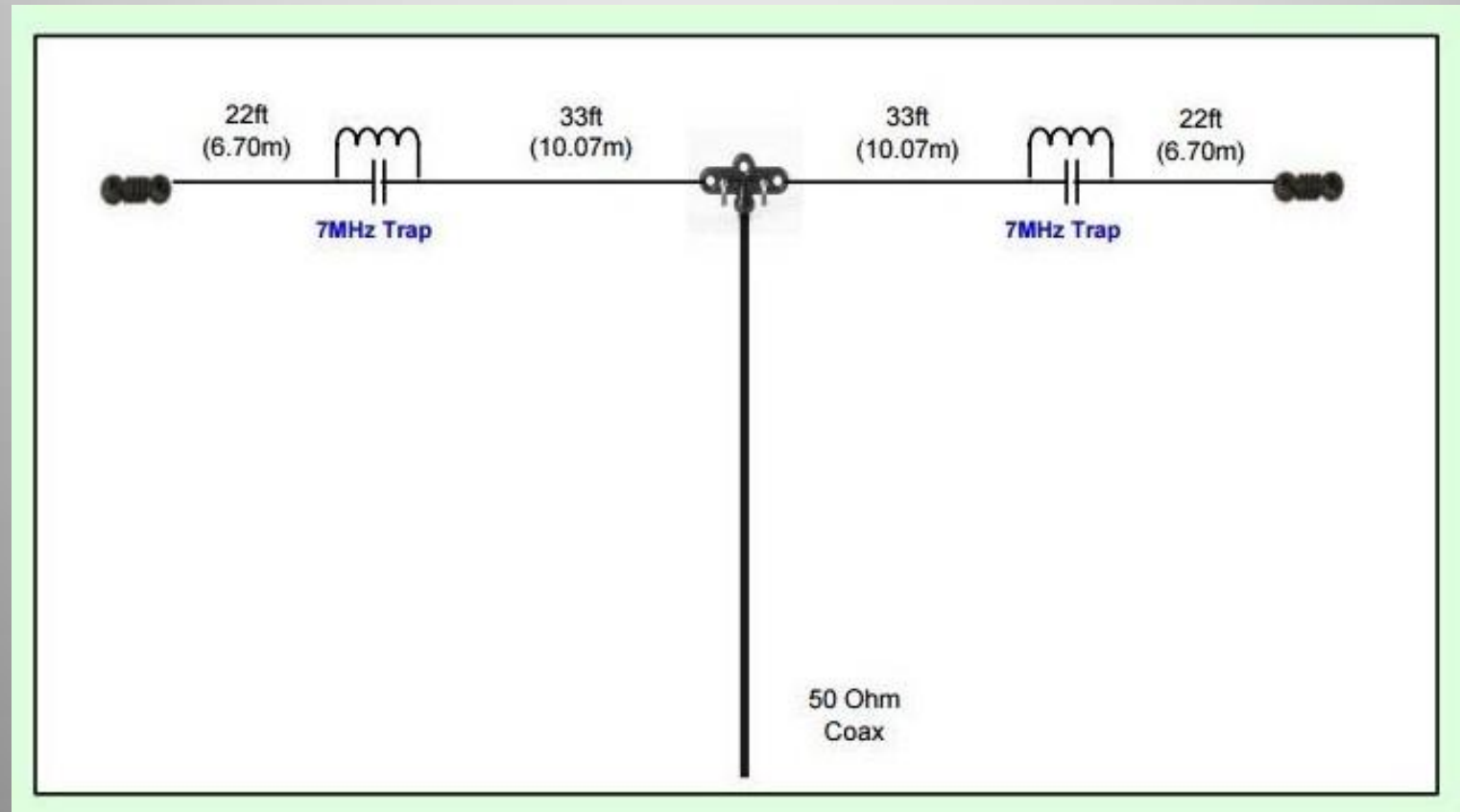

80 and 40 meter **TWO-BAND TRAP DIPOLE**

Trap is high-impedance LC circuit tuned to 7 MHz
Overall length about 110 feet: height 25 feet (NVIS)

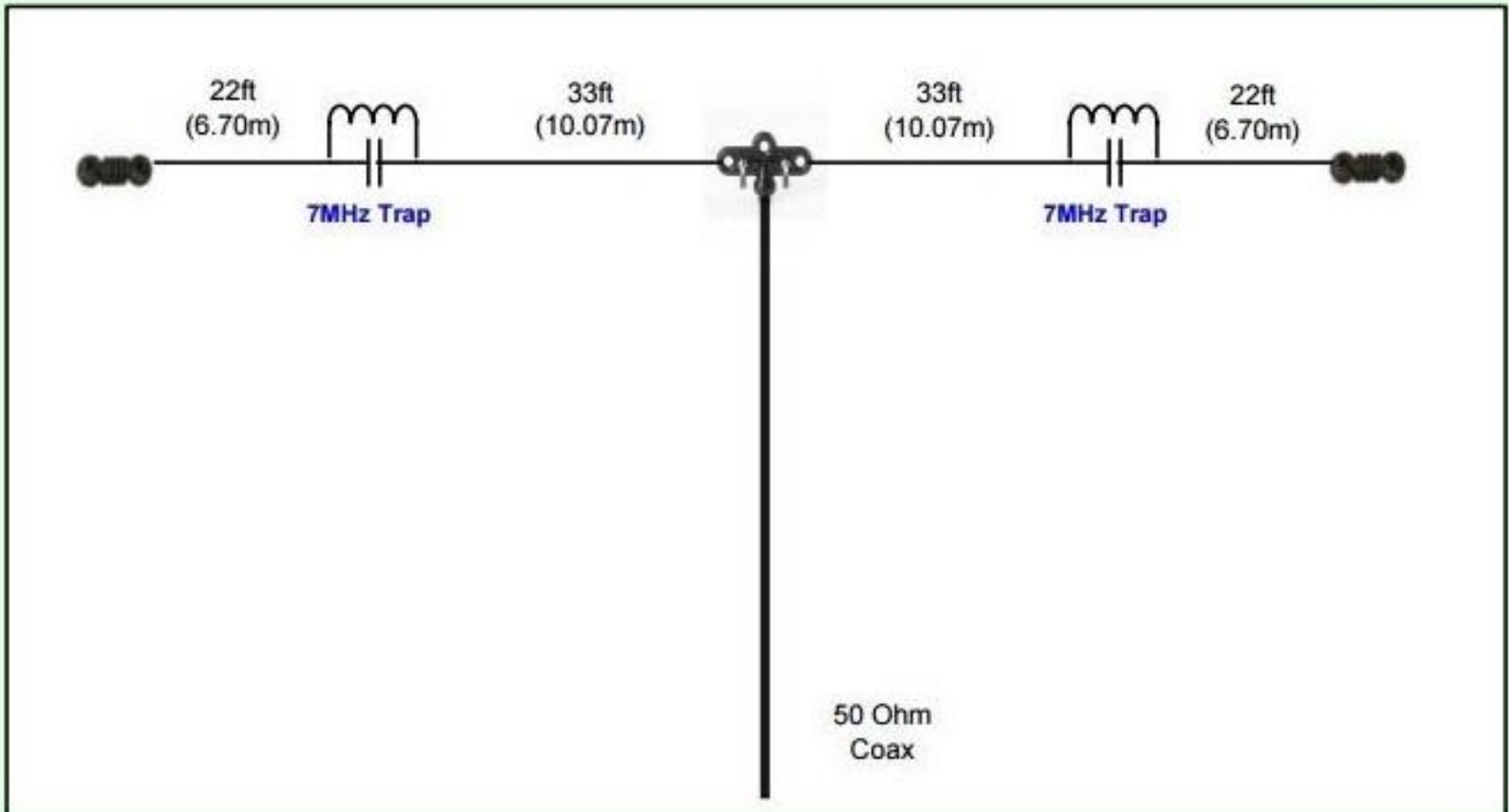

80/40 Trap Dipole RETURN LOSS and SWR

Low SWR on both 80m and 40m

NanoVNA Saver 0.3.7 (Sweep: 2020-12-10 11:29:05 @ 5050 points)

Sweep control

Start Center

Stop Span

5.744kHz/step

Sweep settings ...

Sweep Stop

Markers

Marker 1

Marker 2

Marker 3

Marker 4

Marker 5

Marker 6

Enable Delta Marker

Show data Locked

TDR

71.488 m

Time Domain Reflectometry ...

Reference sweep

Set current as reference

Reset reference

Serial port control

COM7 (NanoVNA) Rescan

Disconnect Manage

Files ... Calibration ...

Display setup ... About ...

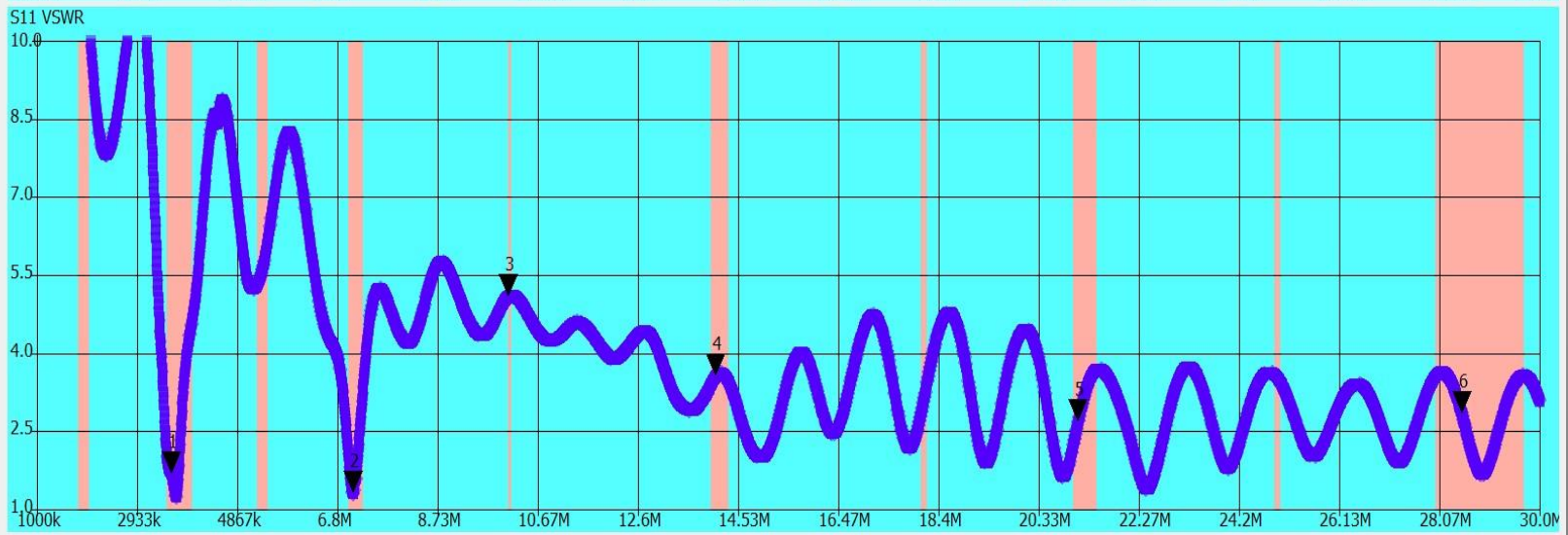
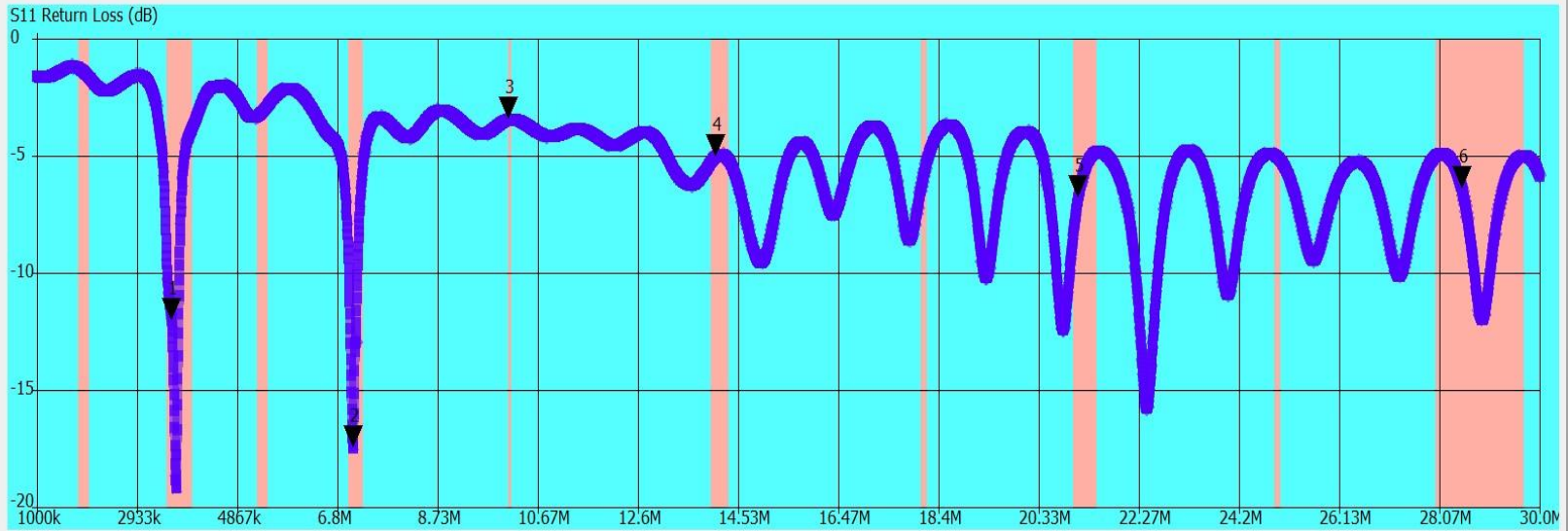

Trap Dipole 80m only all graphs markers #1-6 at 3.5, 3.6, 3.7, 3.8, 3.9, 4.0 MHz

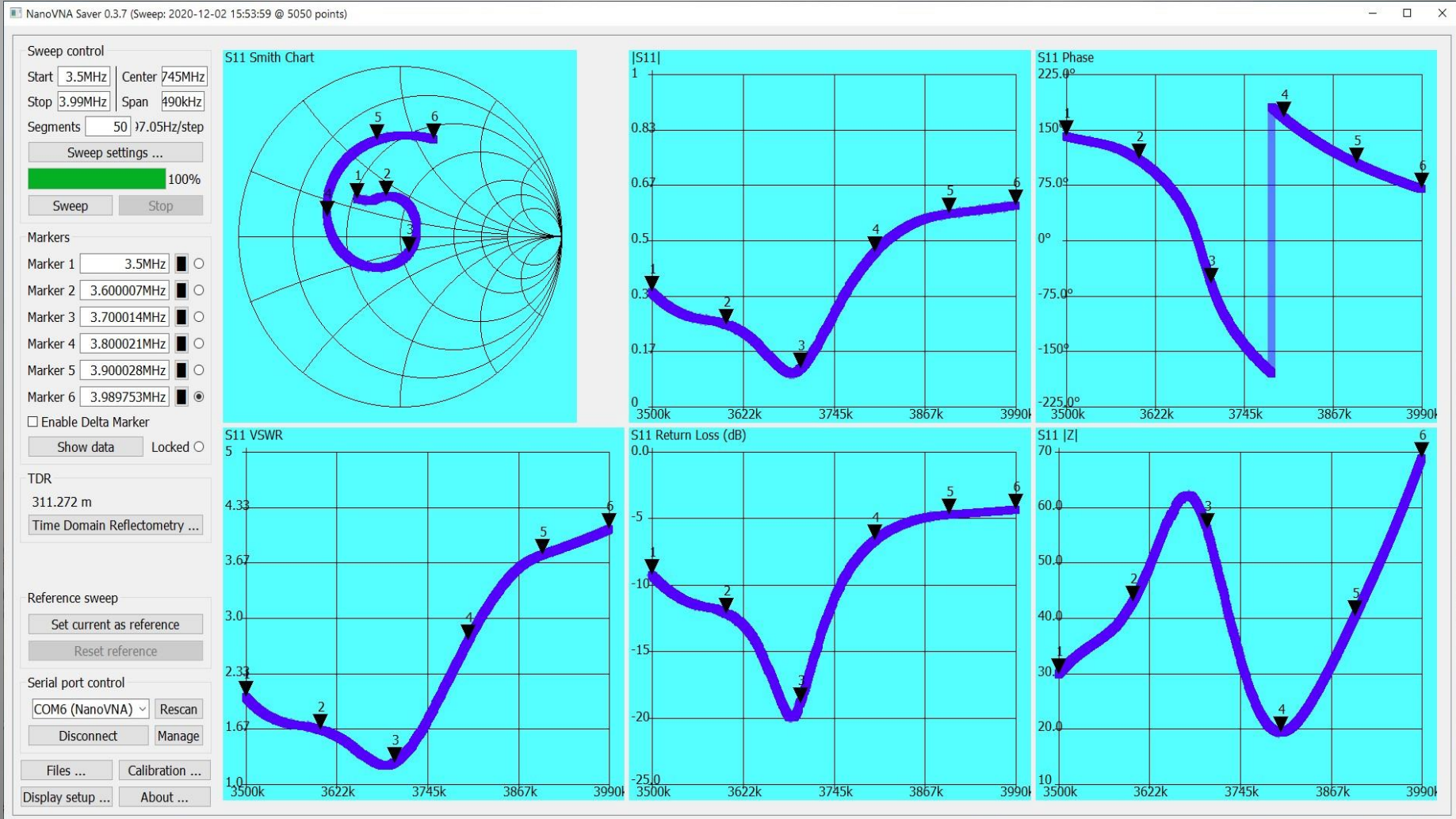

80m Trap Dipole Smith Chart: Bull's Eye SWR 1:1

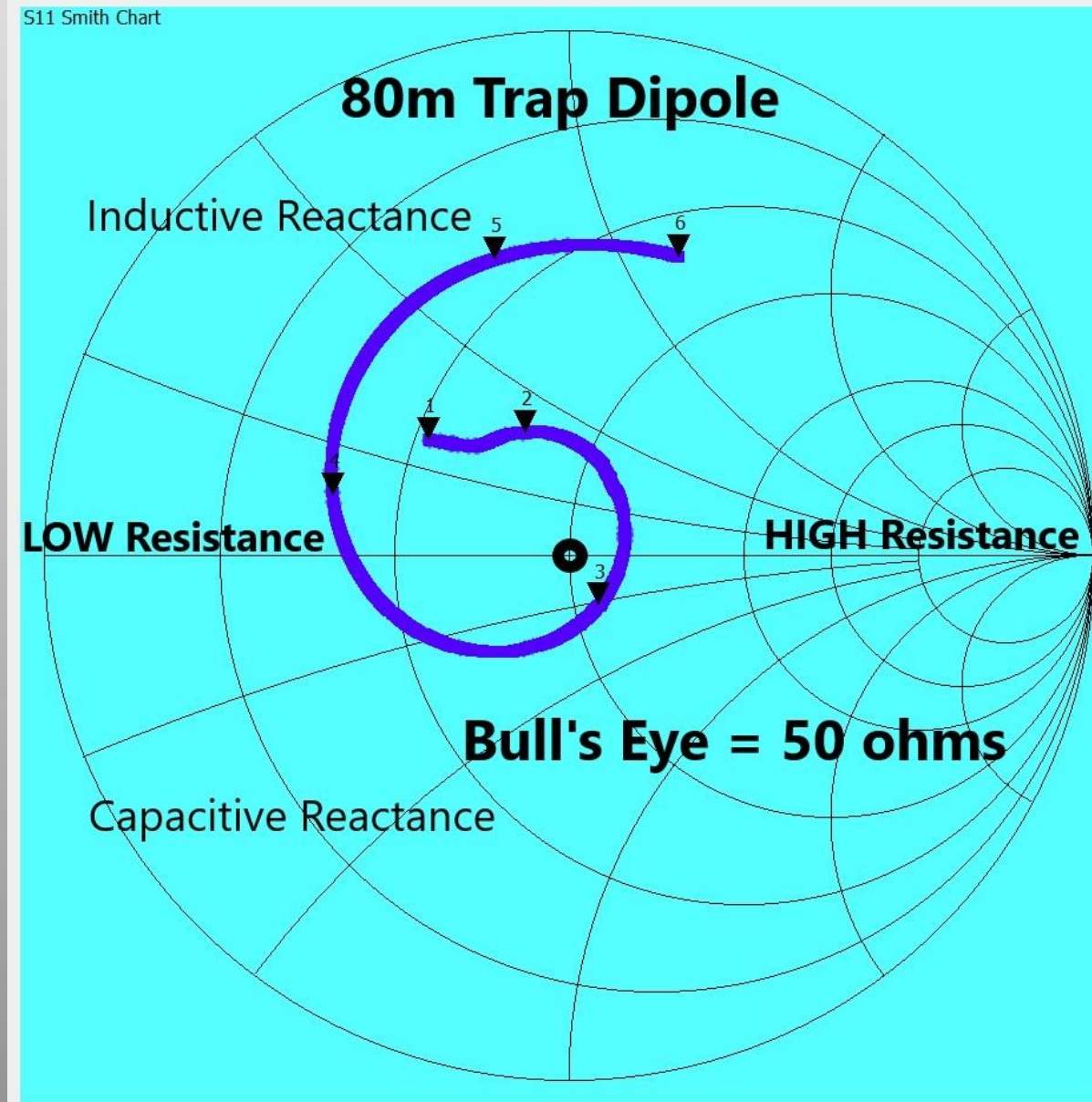

Trap dipole on 40 meters: 7.0 - 7.3 MHz (cut to the low end of 40m band)

S11 Smith Chart

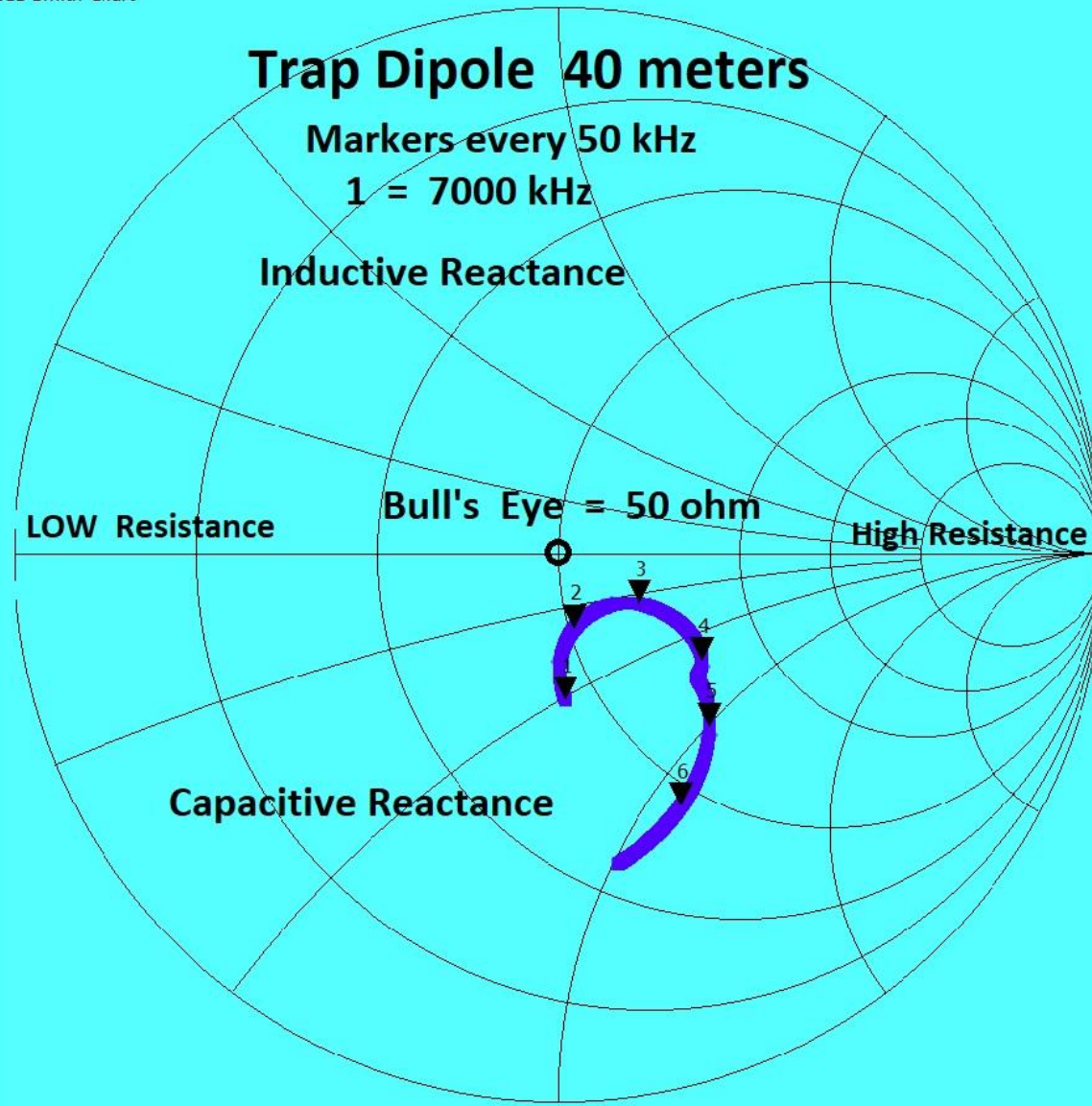

How do “traps” isolate 40m?

LC parallel circuit is a HIGH impedance at the resonant frequency

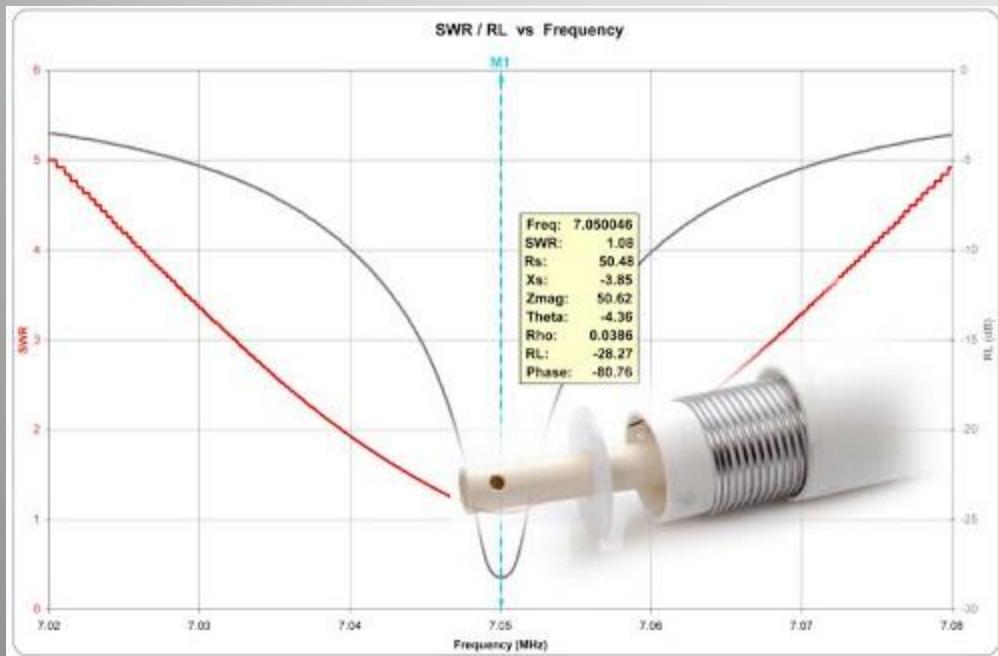

Trap Dipole: Return Loss and SWR looking at the trap resonance 7 MHz

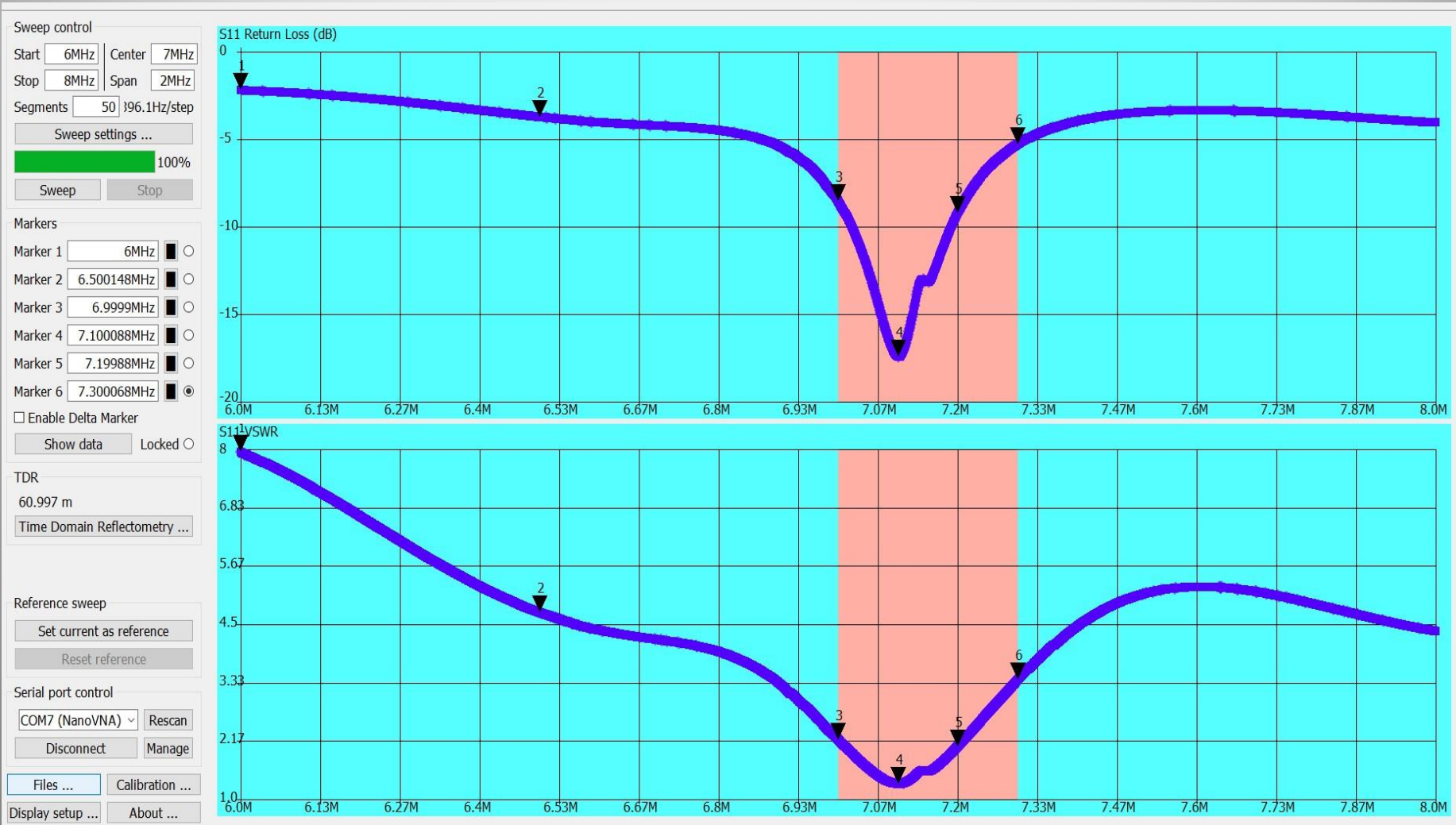

**80m Vertical: 2 inch diameter tubing
40 ft tall with “loading coil” at base and
two 65 ft radials 10 ft above ground**

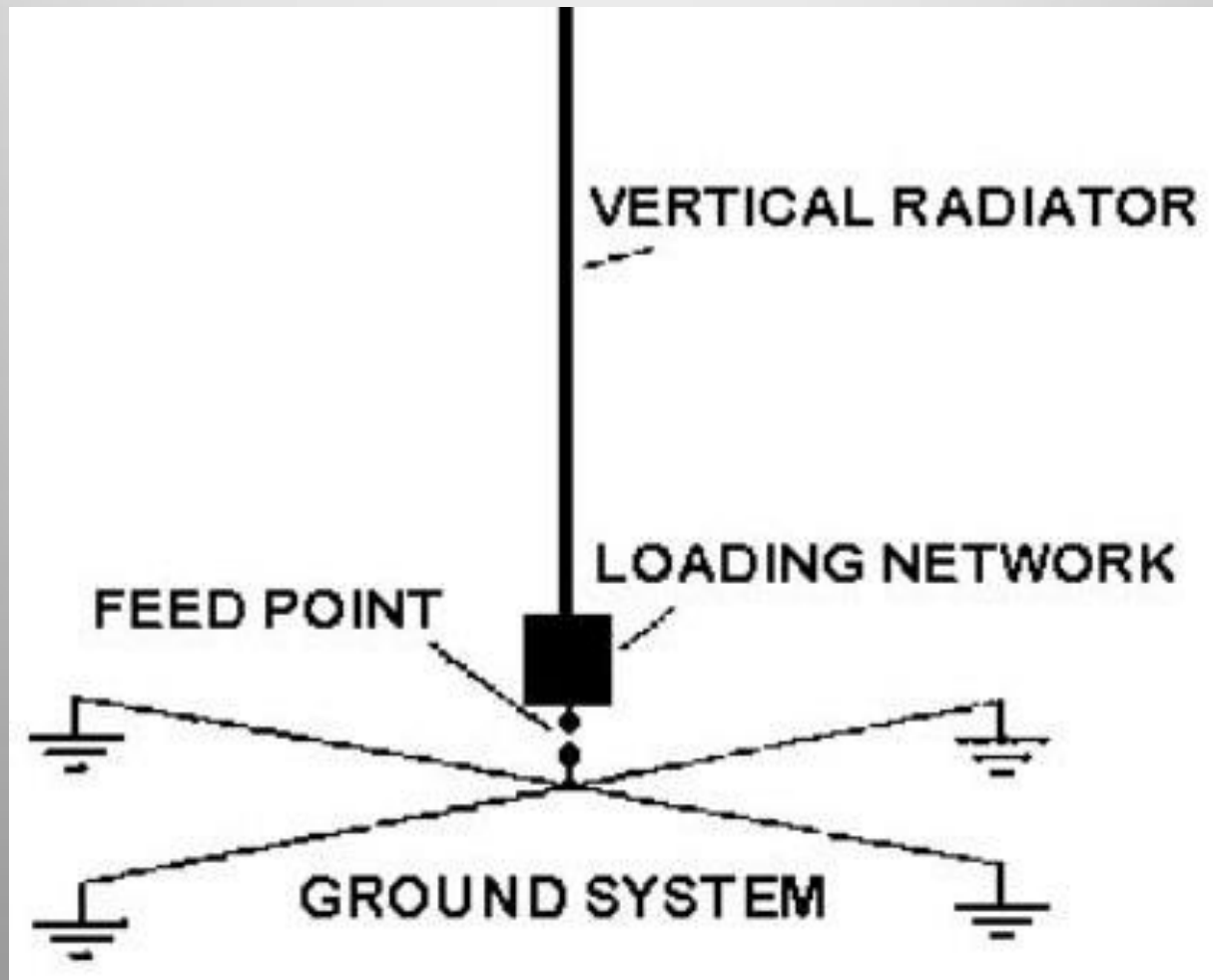

Smith Chart 80 m vertical (unusual pattern) Markers at 3.5, 3.6, 3.7, 3.8, 3.9, 4.0 MHz

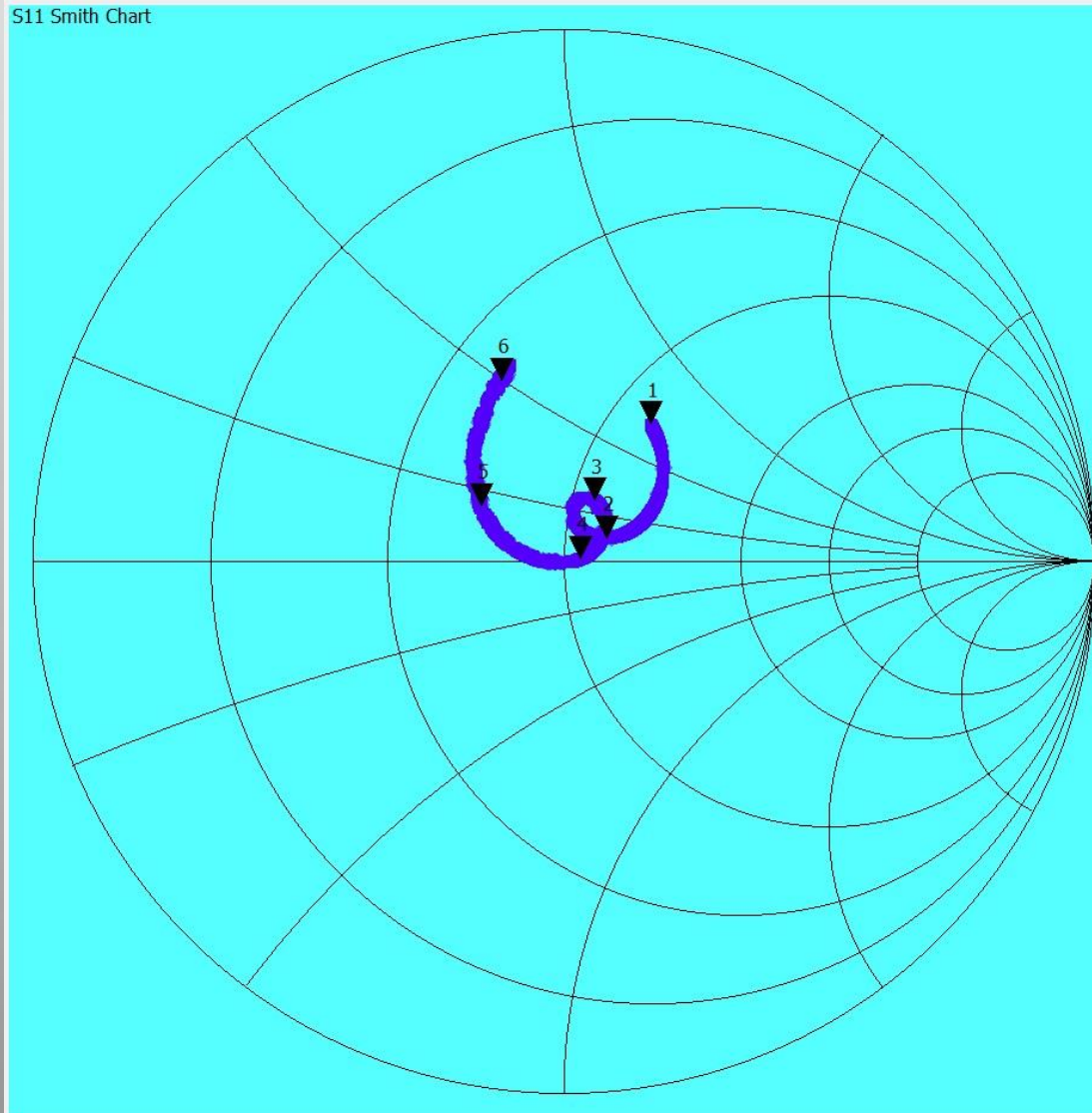

80m Vertical RETURN LOSS and SWR cut for the middle of the band 3800 kHz

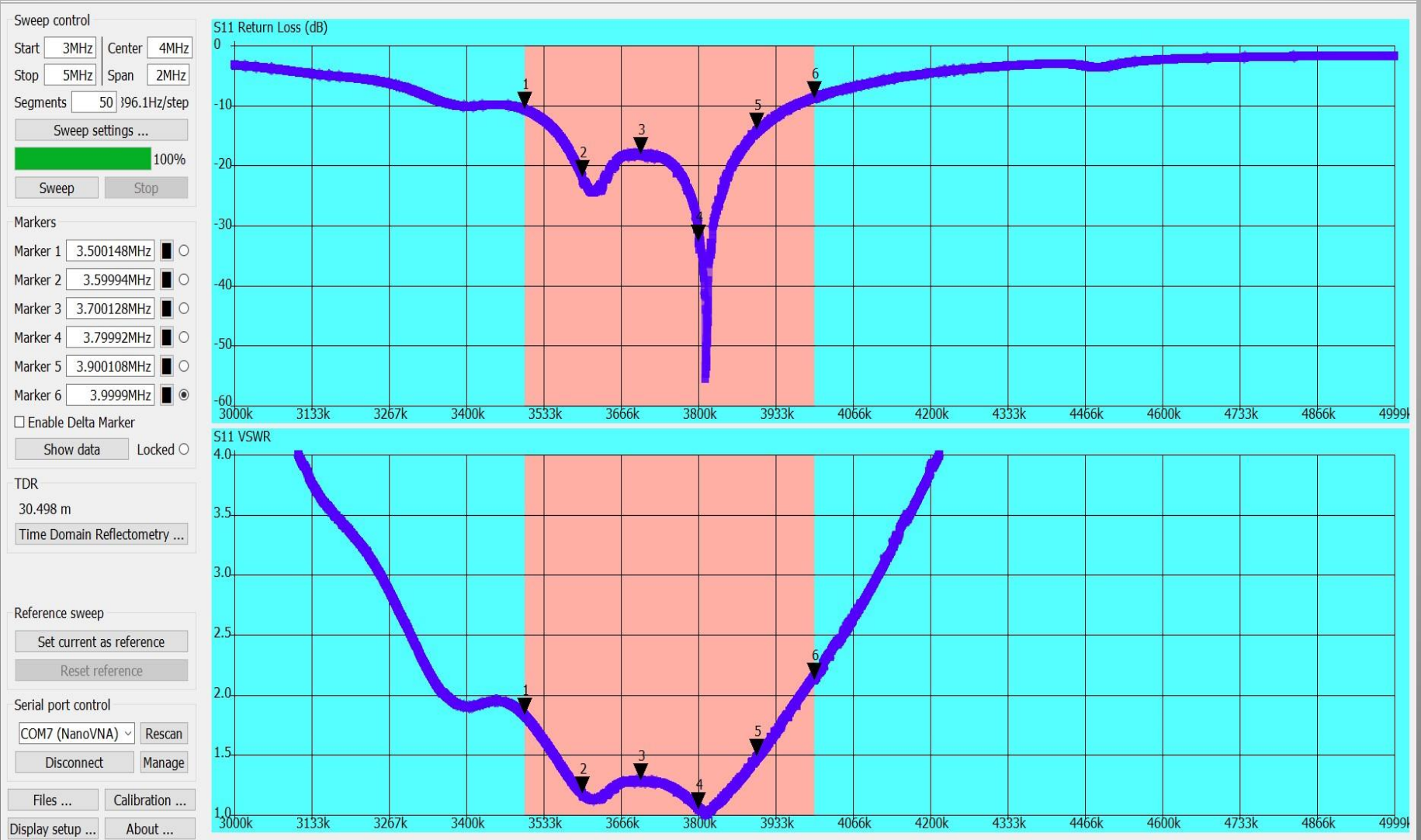

Single Band Vertical “ground plane”



20 meter home brew vertical: 17 ft high with 17 ft radials
this is obviously **mistuned** to 13.7 MHz

Conclusion: shorten the vertical and the radials to about 16.5 feet

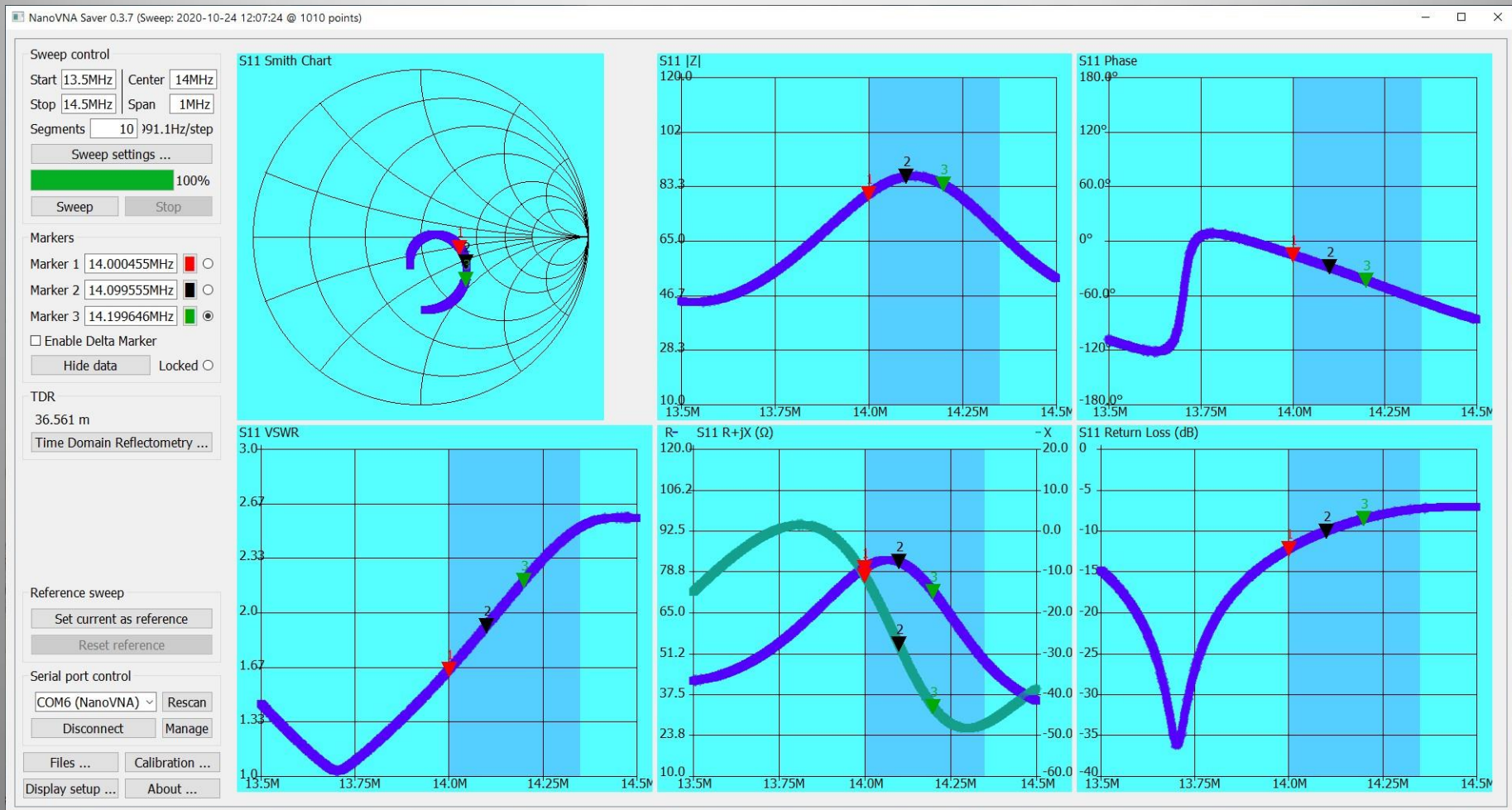

OR -- Insert Antenna Tuner in shack

This makes rig happy

**RIG sees 50 ohm Z and SWR=1:1 at rig's port
but tuner in shack does NOT change SWR on line**



New SWR across 20m looks great < 1.7 : 1 across band
So do we now have more power radiated by antenna?

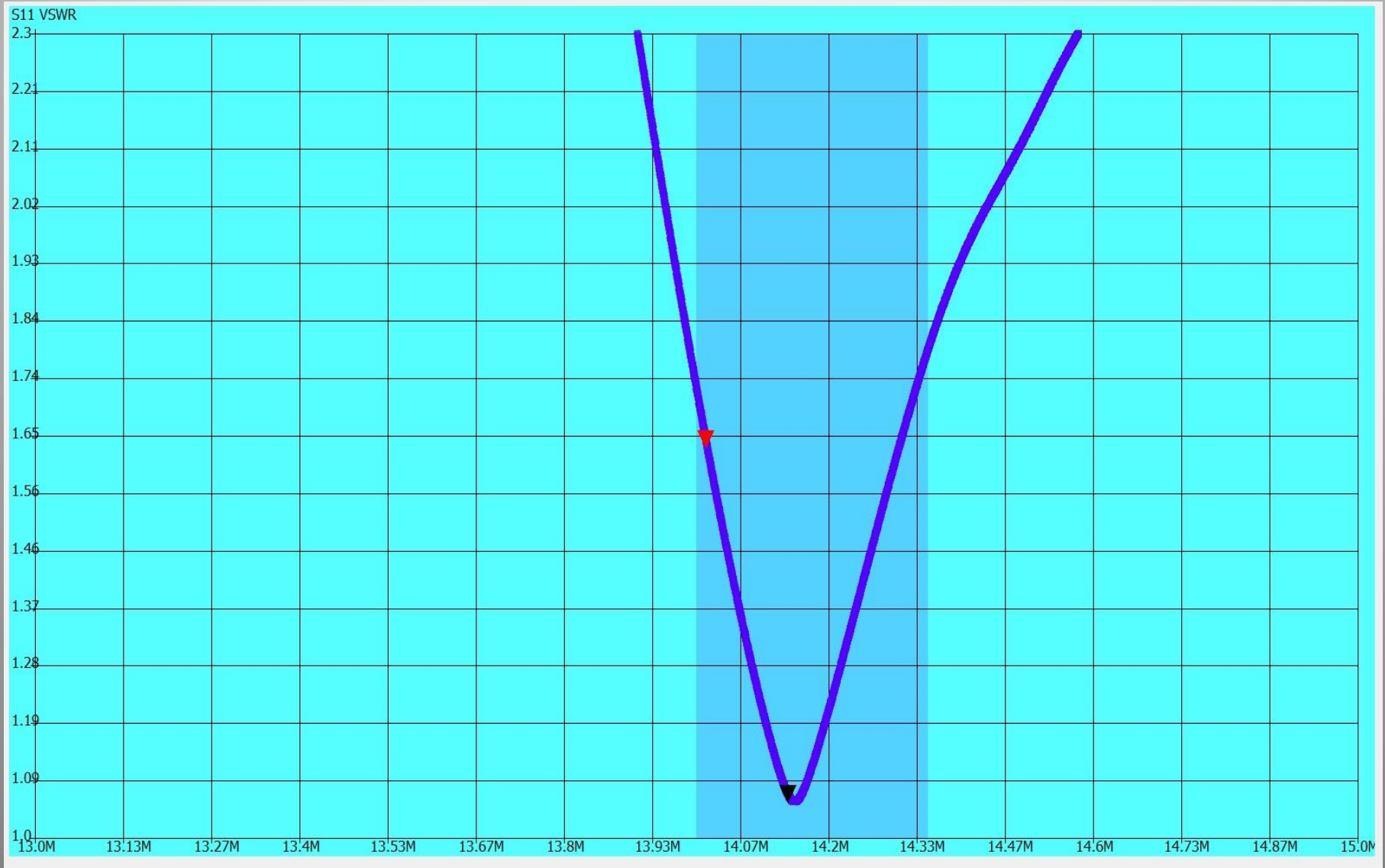

Cushcraft R5 ½ wave Vertical (5 bands)
 with four “traps” for 10/12/15/17 m bands
 (Traps act as parallel tuned High-Z circuits to isolate each band)

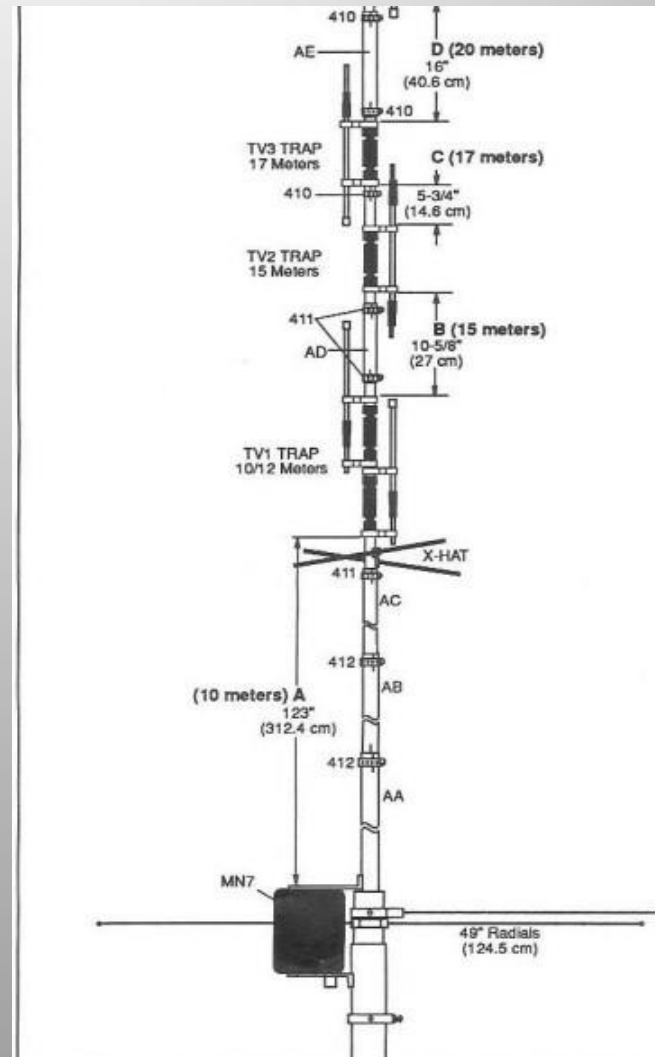
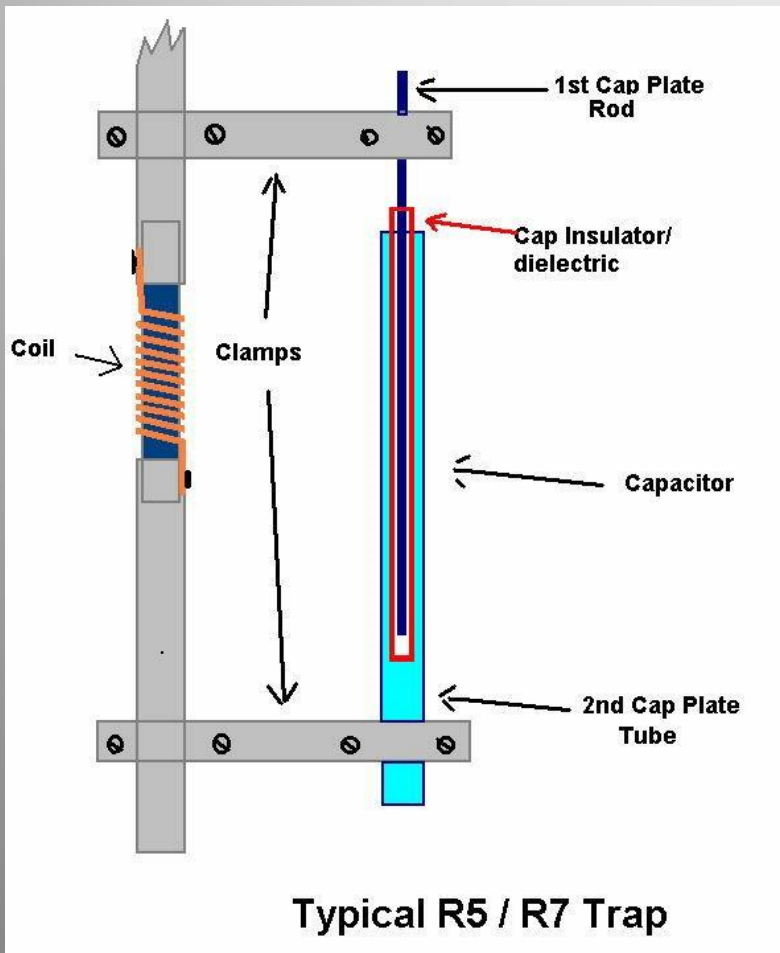

**Cushcraft R5
(traps for 10/12/15/17 meters)**

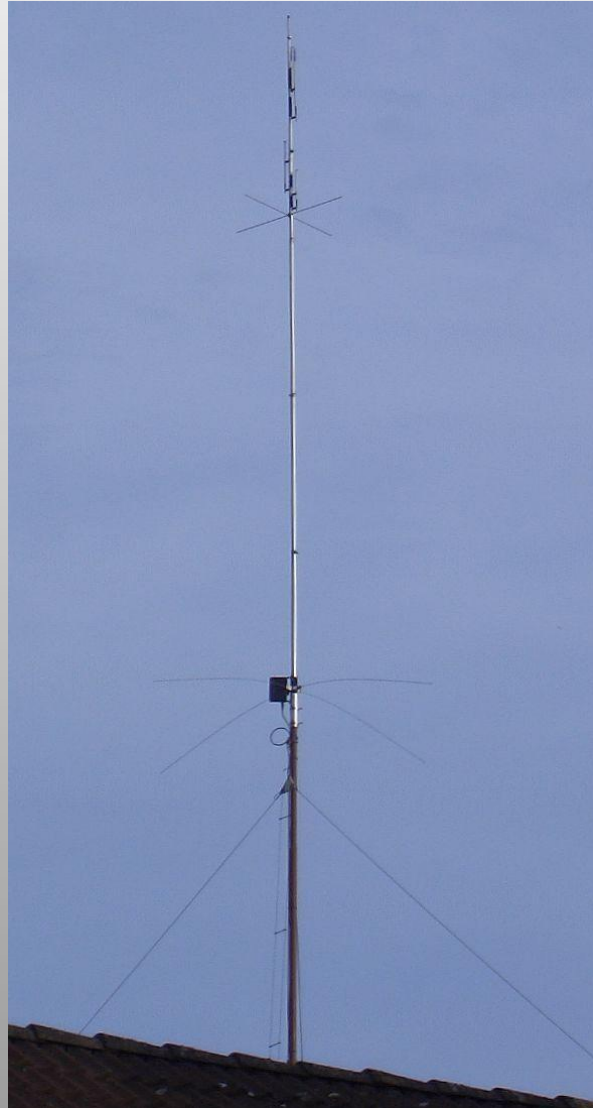

Cushcraft R5: 5 Band Resonances

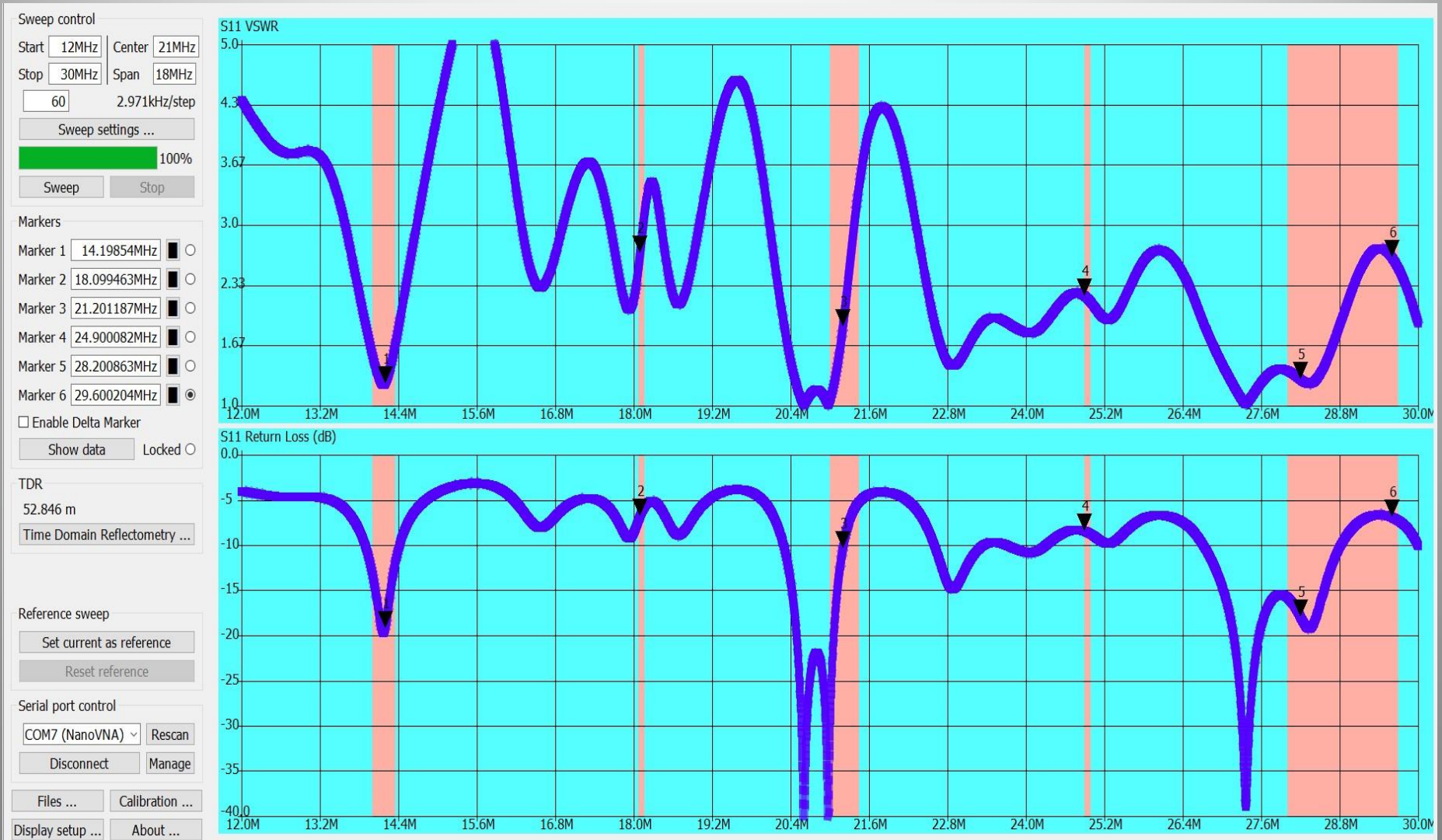

Cushcraft R5: 20m only Resonance 14.2 MHz

note PHASE plot agrees with SWR plot

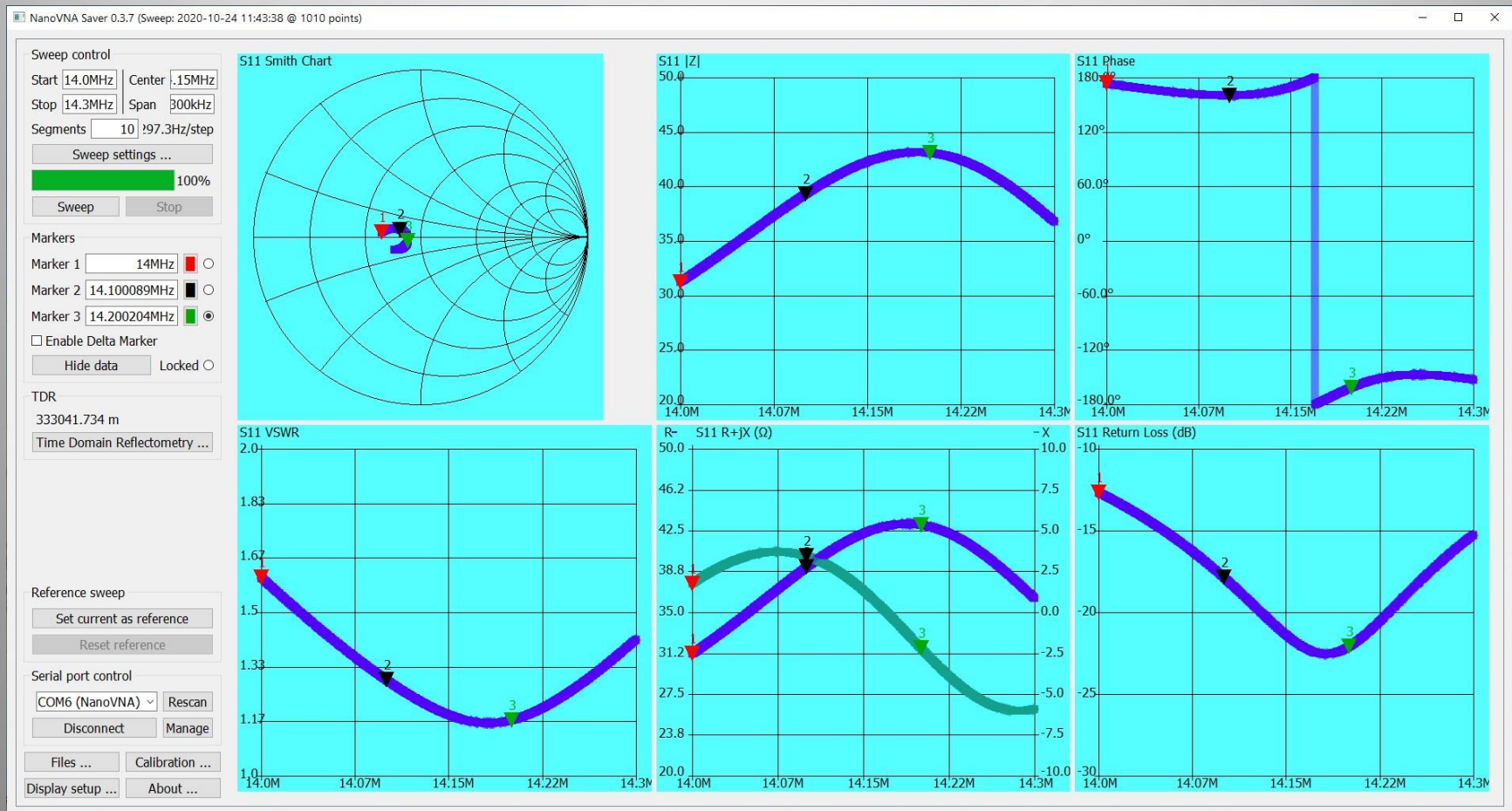

Cushcraft R5 10m only

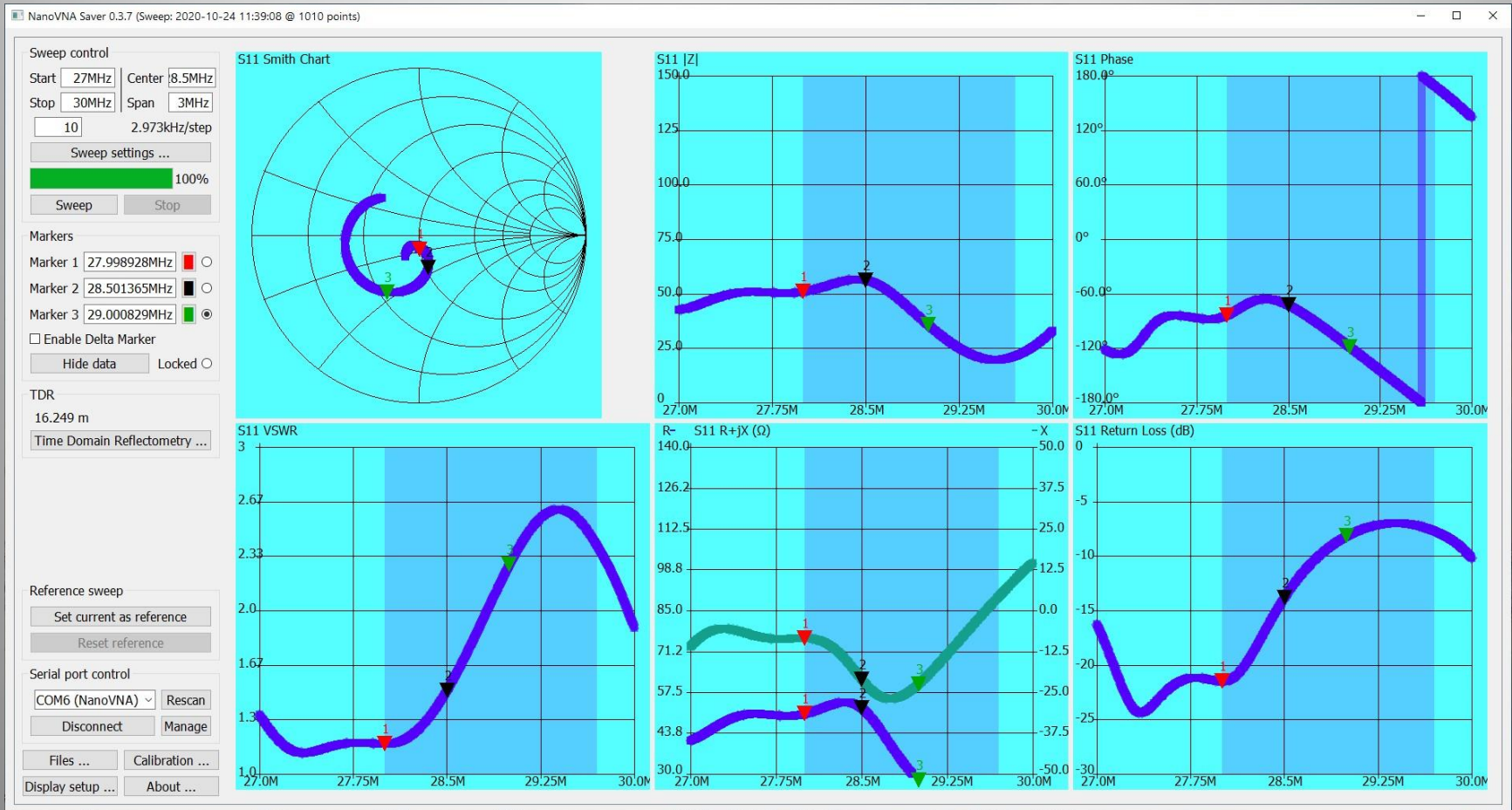

Cushcraft 10 element 2m beam



The “**Gamma Match**” is an UN-BALANCED circuit used to match the low impedance of beam to 50 ohms for coax

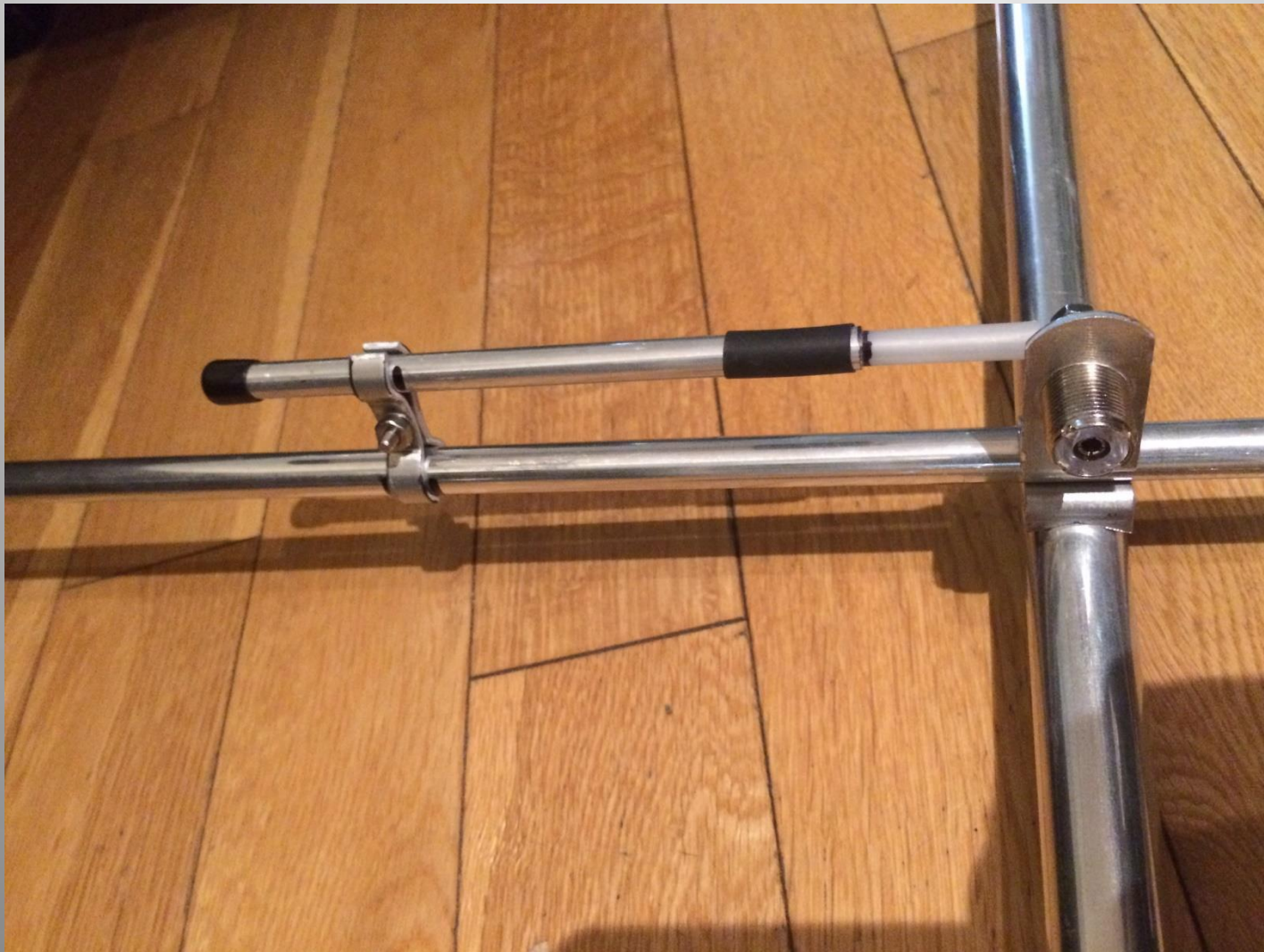

Cushcraft “**Ultra-Match**” is just two Gamma matches but provides a BALANCED approach relative to ground

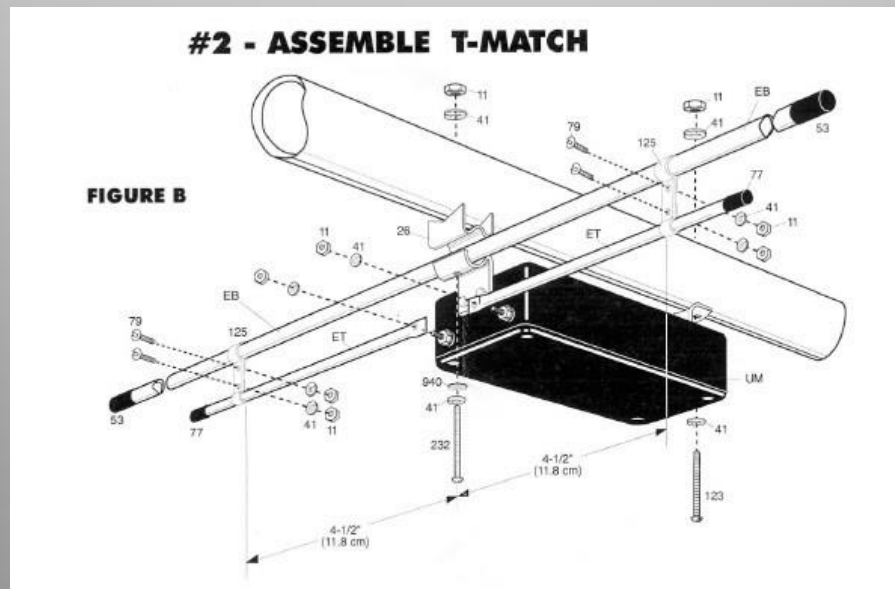

SWR Cushcraft 10 element 2m BEAM

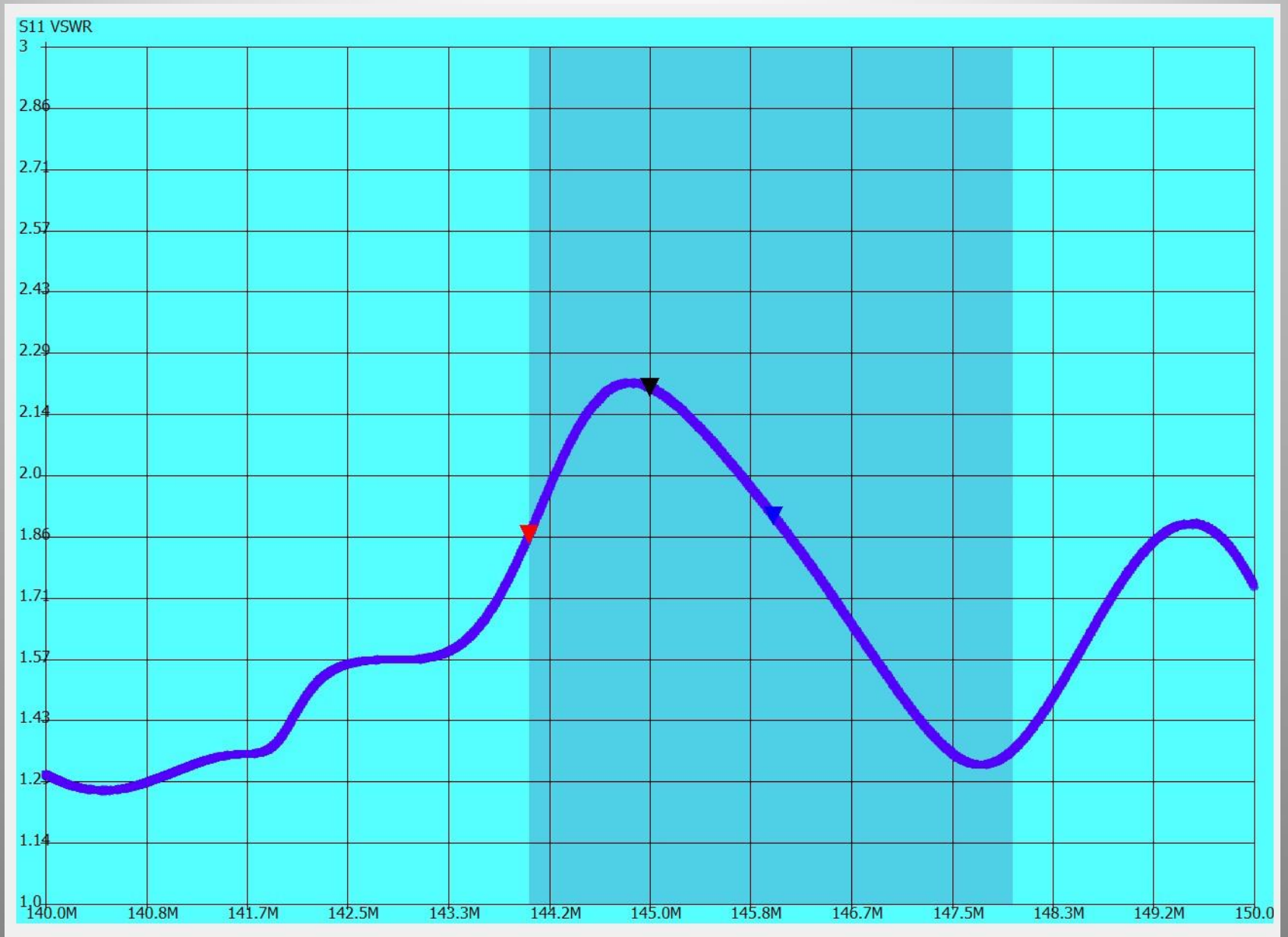

Impedance Cushcraft 2m BEAM

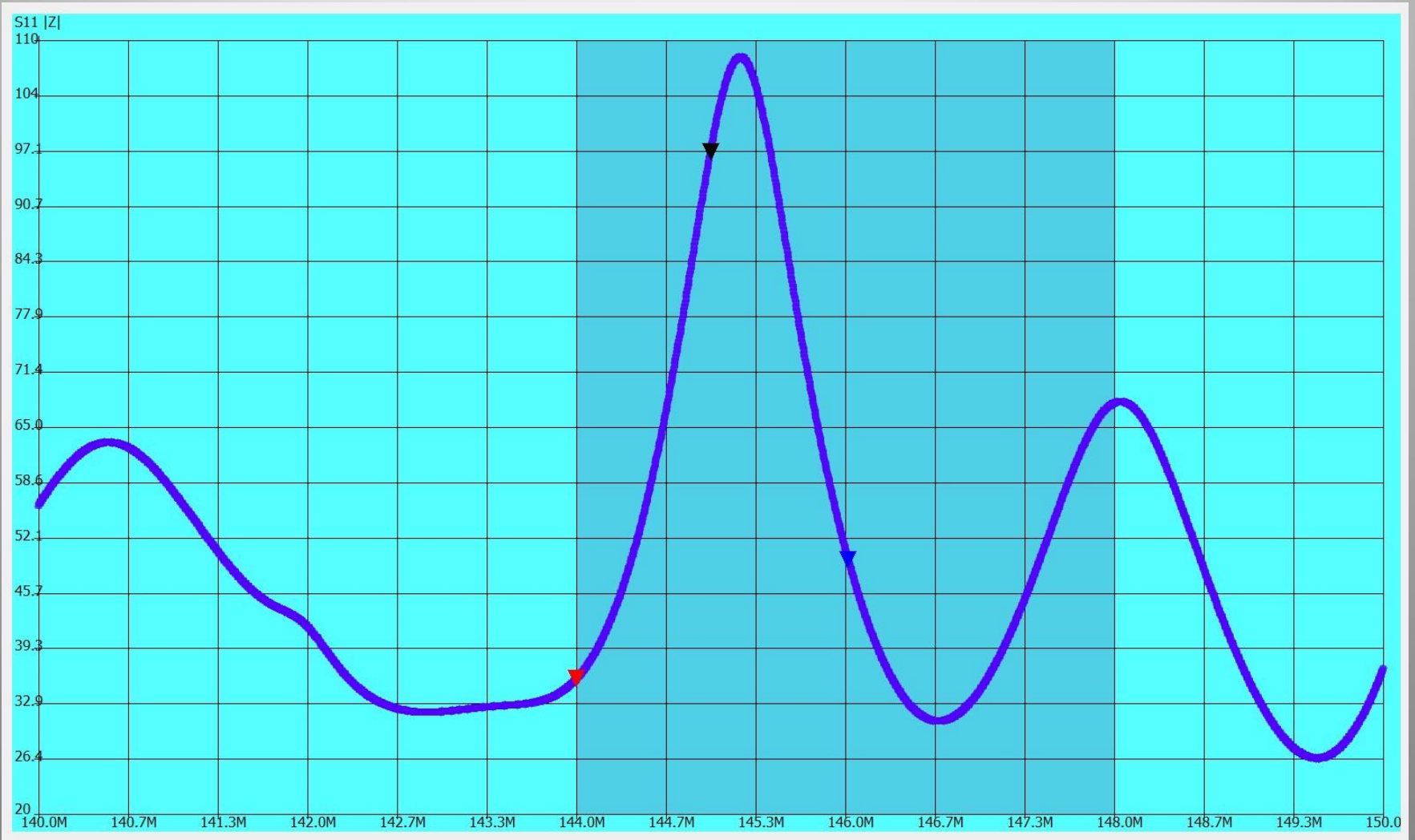

Cushcraft 11 element 70cm BEAM
now SWR is getting to be critical - why?



SWR Cushcraft 11 element 70 cm BEAM

note SWR < 2:1 from 400 – 500 MHz

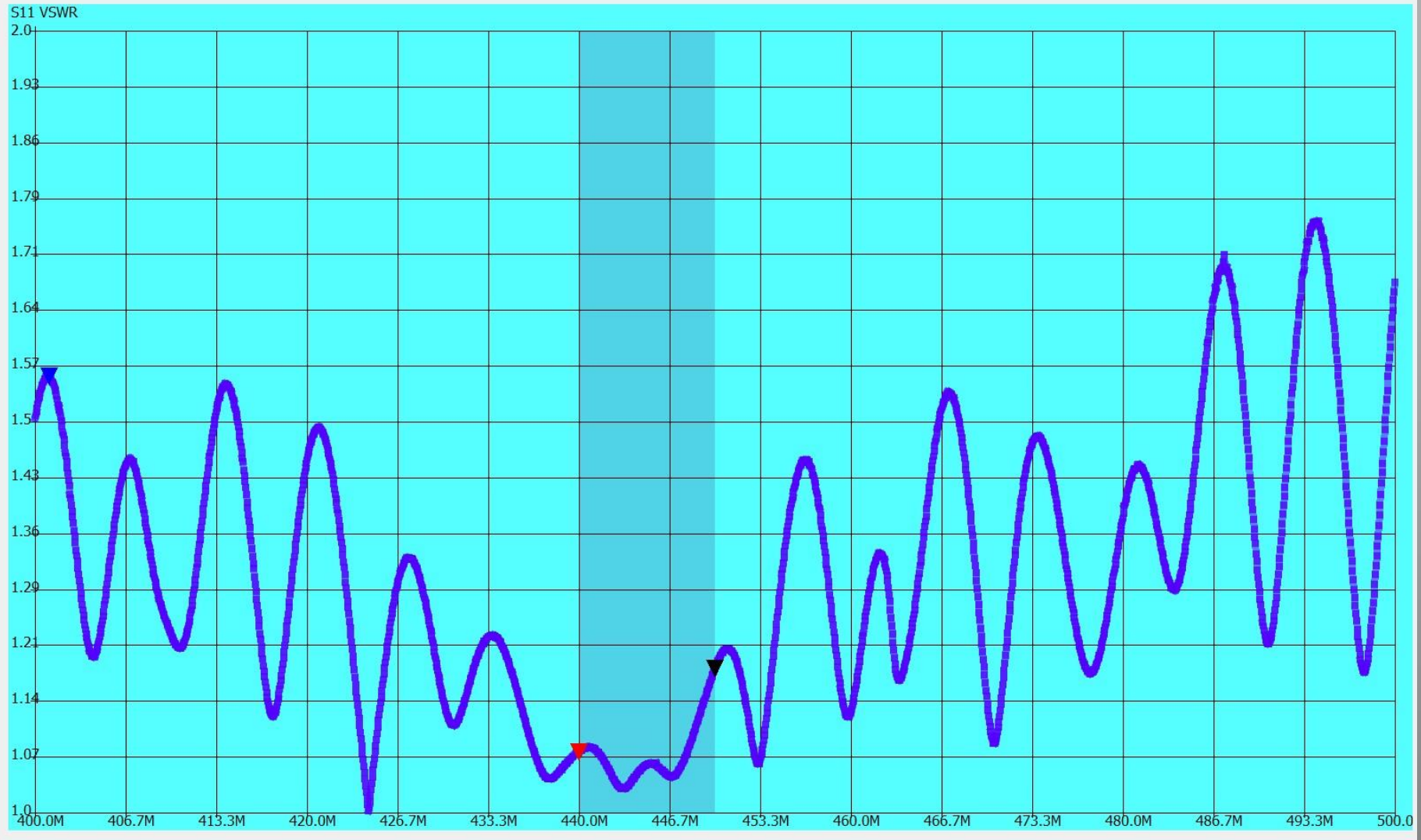

Diamond Dual Band 2m/70cm Vertical



Diamond VHF/UHF Vertical

2 meters: SWR and RETURN LOSS

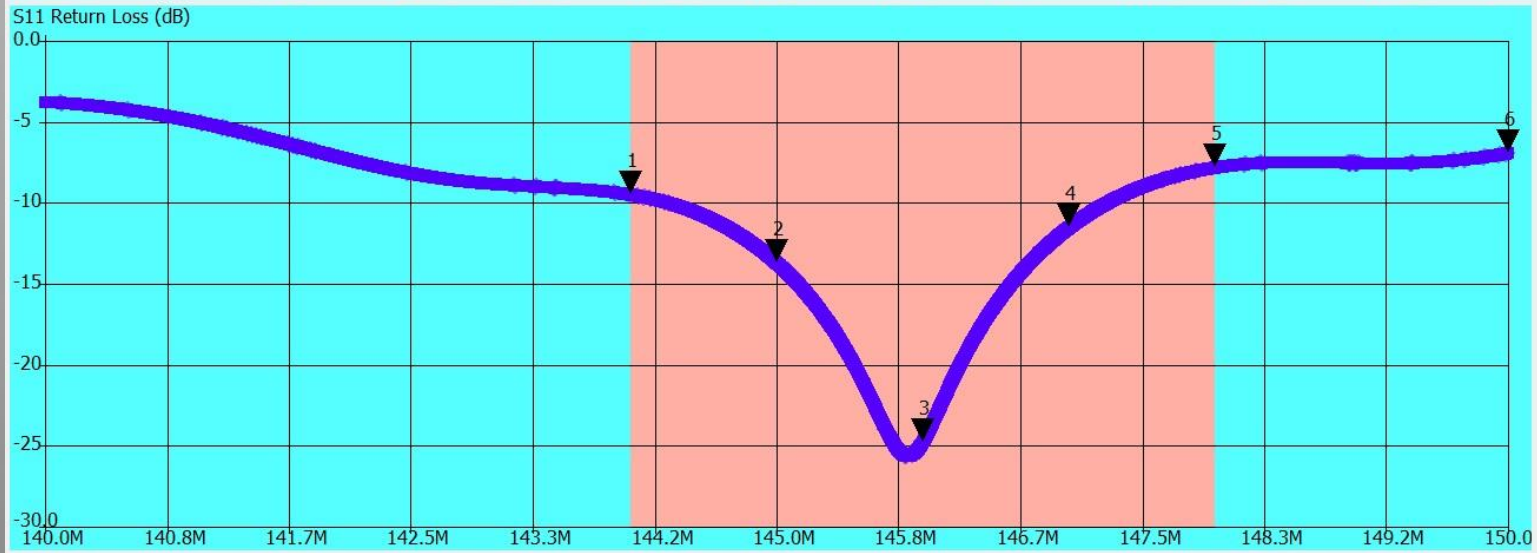
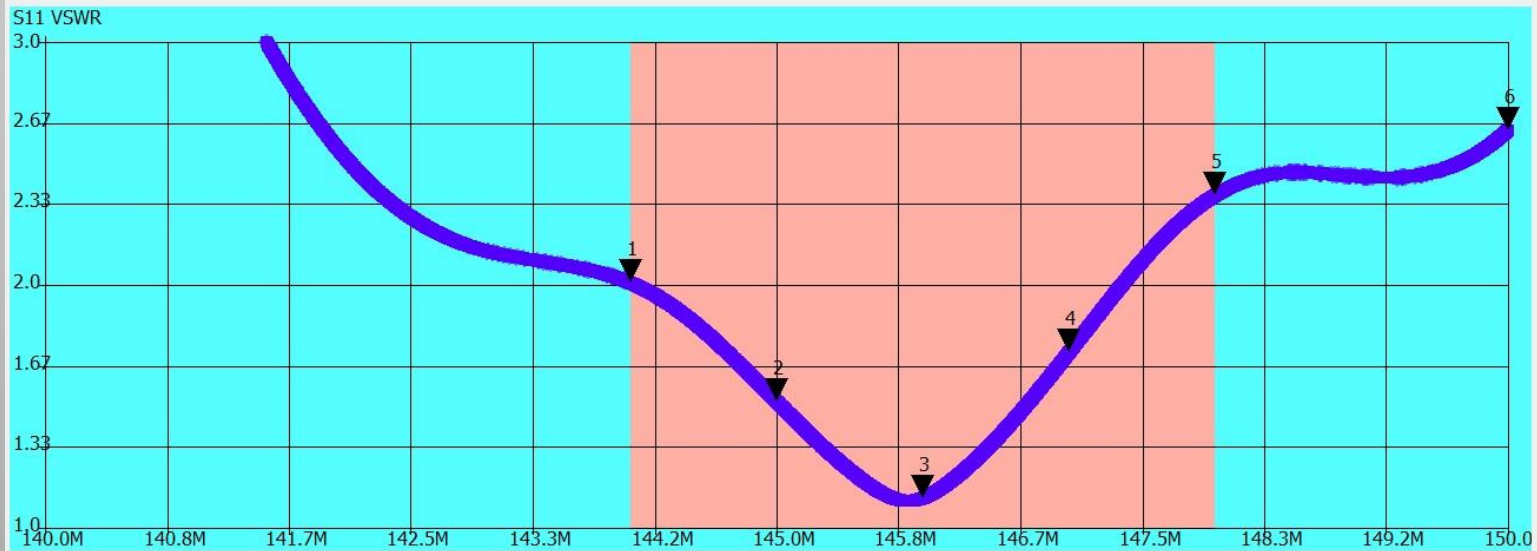

Dual Band VHF/UHF vertical

430 – 450 MHz

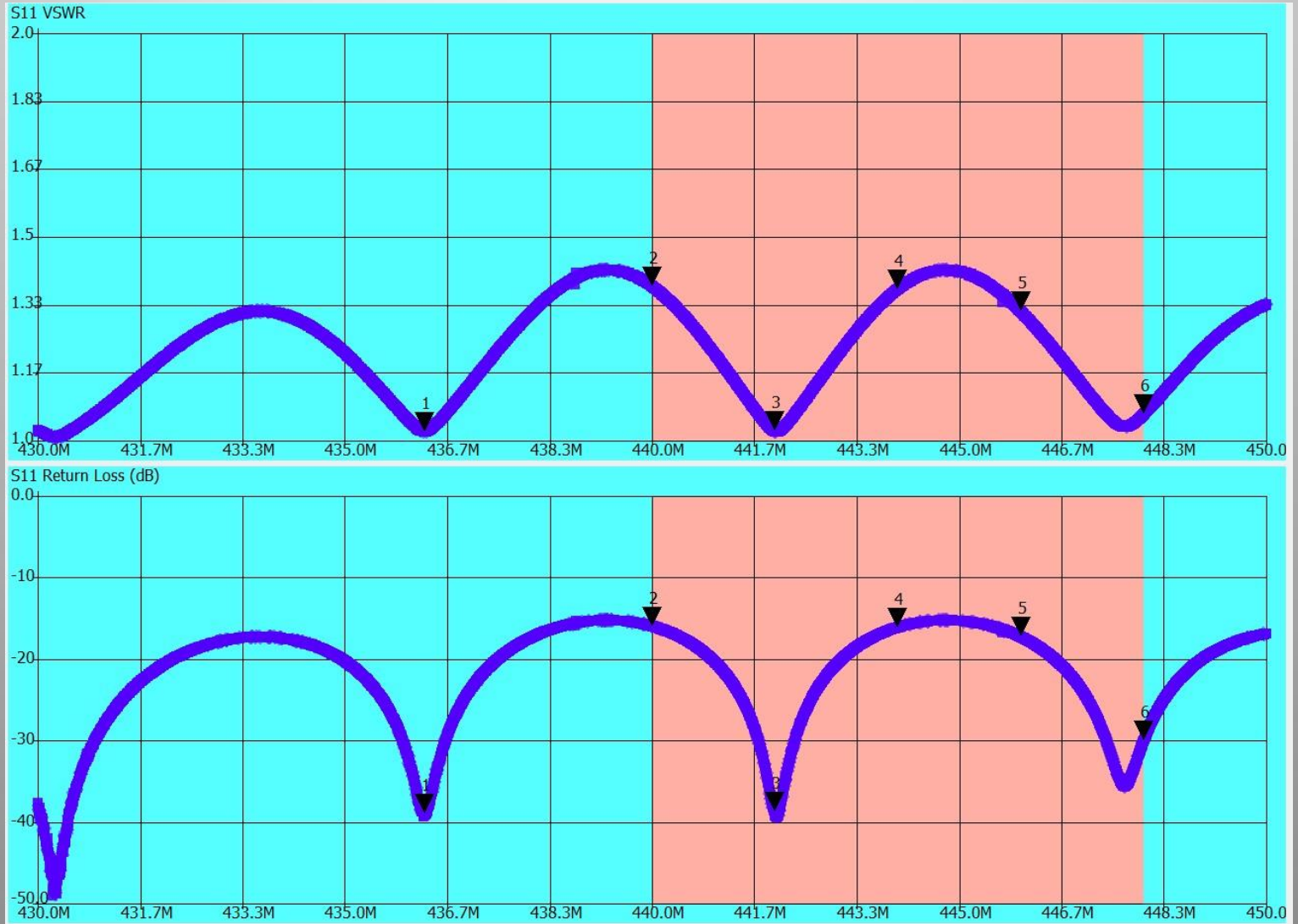

Hustler G6 2 meter vertical “gain” antenna



Hustler G6 2m vertical broad tuning across 2m band

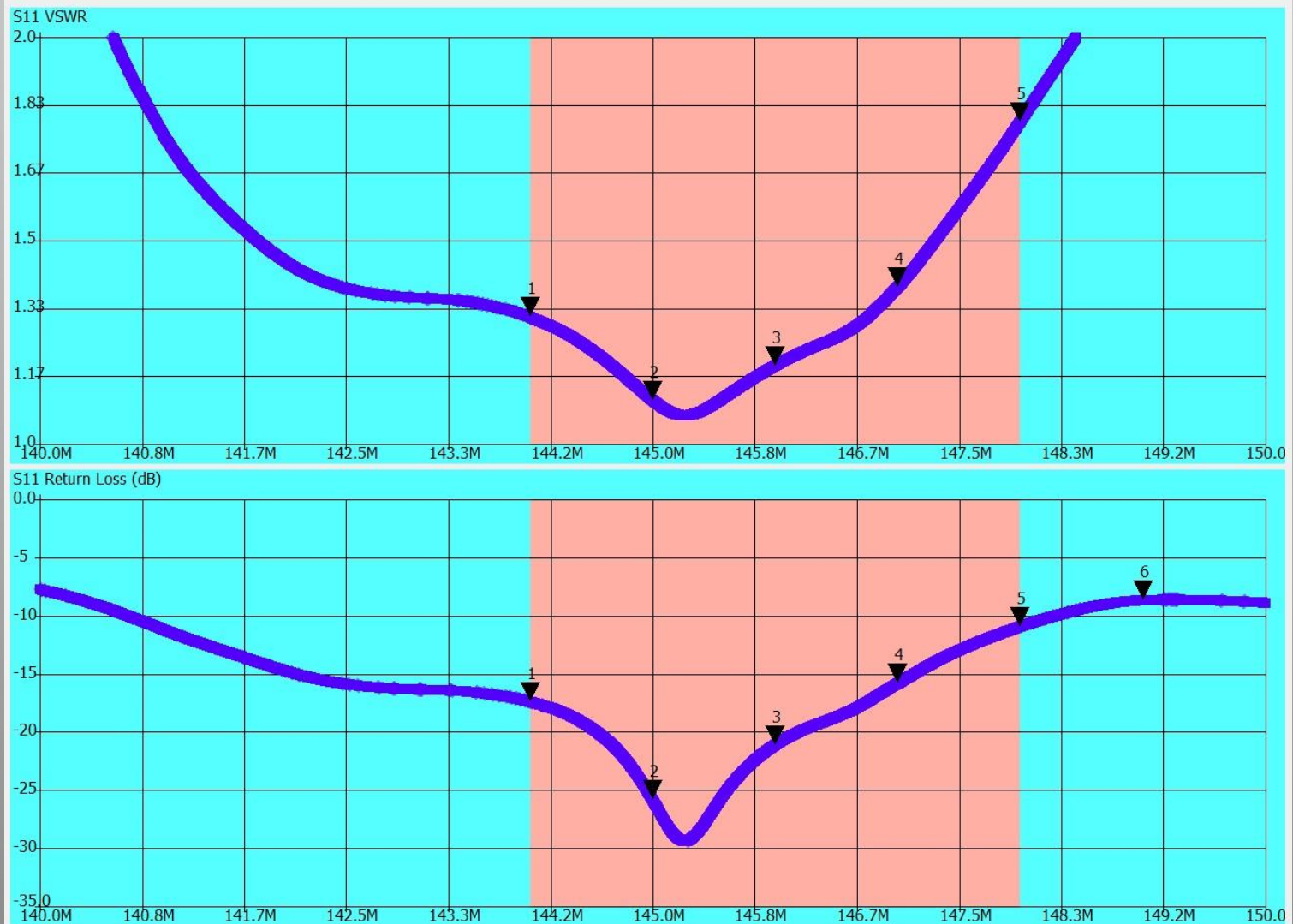

MFJ 3 element 2 meter beam this one needs some tuning!

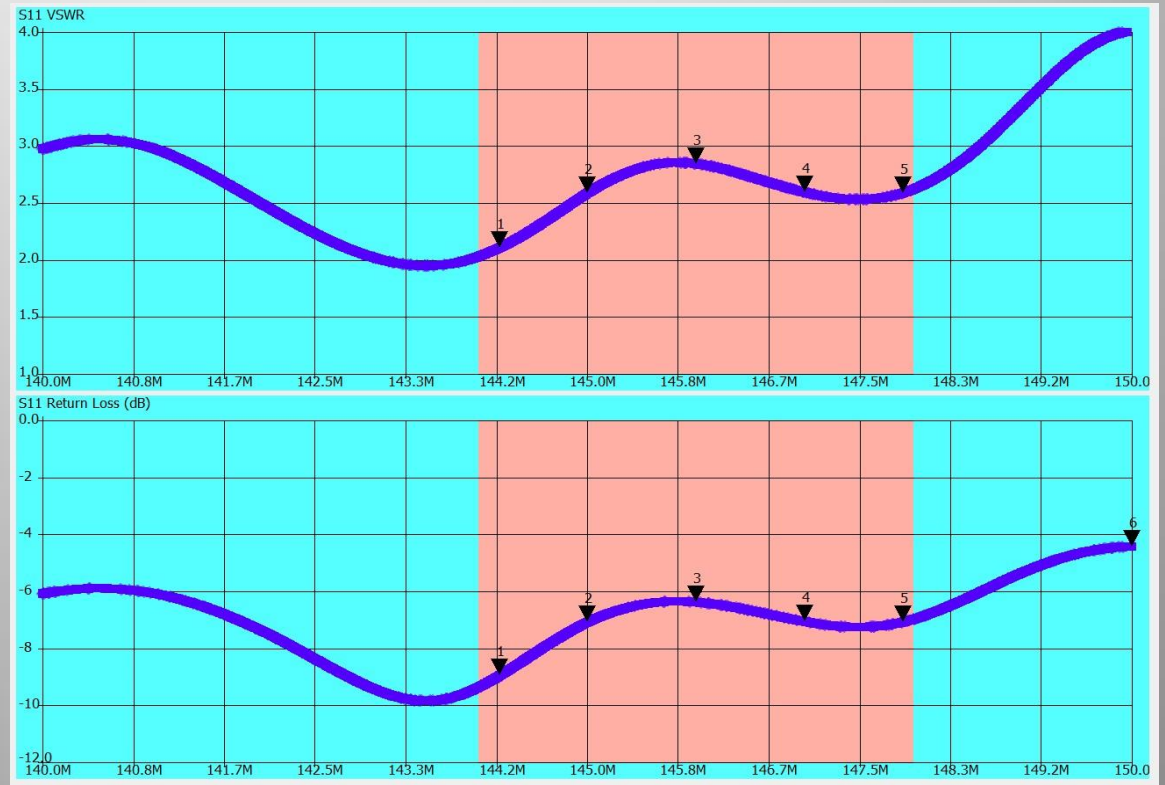

Other uses for a Nano VNA

Measure Cable Length

Measure Cable characteristic impedance (Z)

Measure Cable loss (attenuation) in dB/100 ft

Measure the Q (sharpness) of an antenna trap

Measure the inductance L of a coil

Measure the capacitance C of a capacitor

Measure the impedance Z of a RLC circuit

Measure PHASE ANGLES

Useful Adapter: SMA to S0239
but is the impedance still 50 ohms at UHF

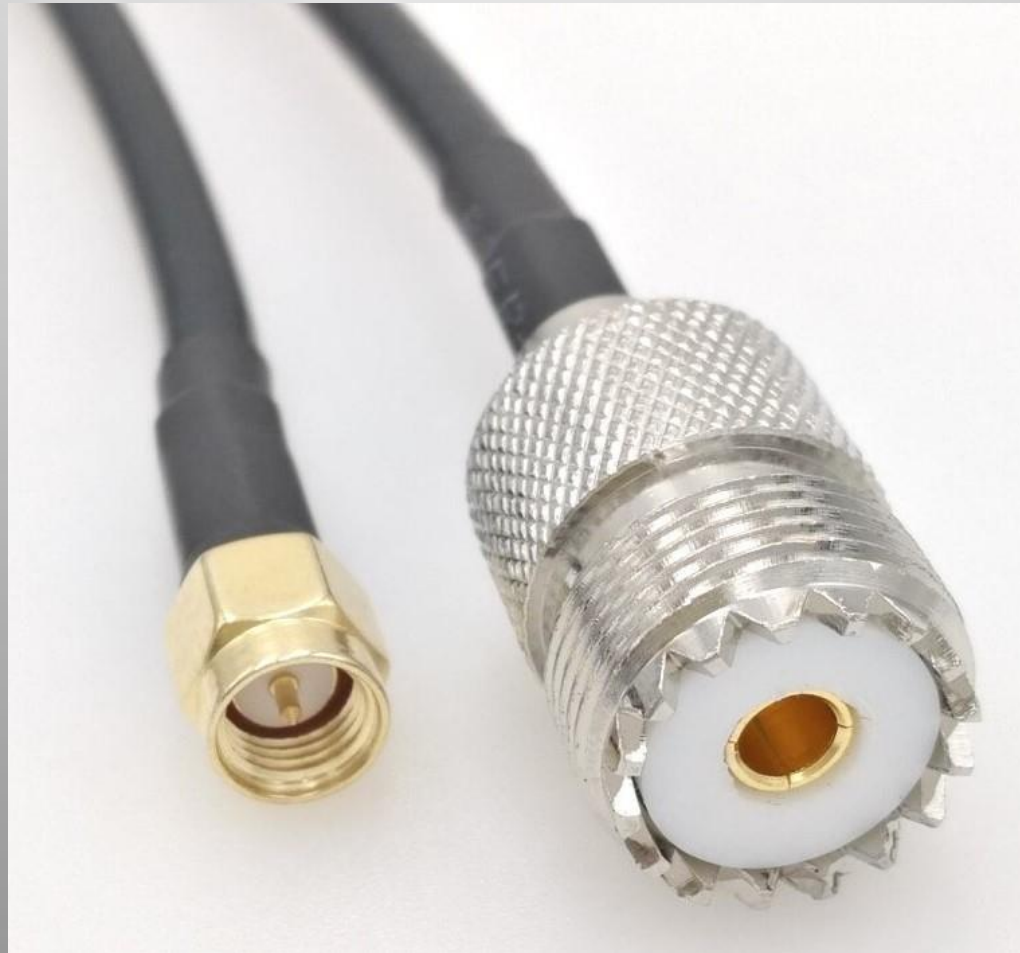

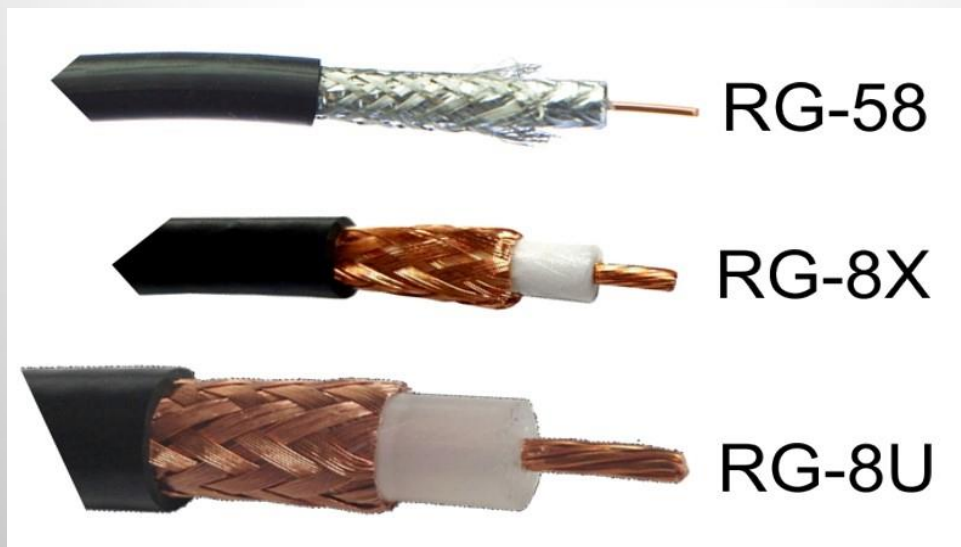

Attenuation (dB per 100 feet)

Coax Cable Signal Loss (Attenuation) in dB per 100ft*

Loss*	RG-174	RG-58	RG-8X	RG-213	RG-6	RG-11	RF-9914	RF-9913
1MHz	1.9dB	0.4dB	0.5dB	0.2dB	0.2dB	0.2dB	0.3dB	0.2dB
10MHz	3.3dB	1.4dB	1.0dB	0.6dB	0.6dB	0.4dB	0.5dB	0.4dB
50MHz	6.6dB	3.3dB	2.5dB	1.6dB	1.4dB	1.0dB	1.1dB	0.9dB
100MHz	8.9dB	4.9dB	3.6dB	2.2dB	2.0dB	1.6dB	1.5dB	1.4dB
200MHz	11.9dB	7.3dB	5.4dB	3.3dB	2.8dB	2.3dB	2.0dB	1.8dB
400MHz	17.3 B	11.2dB	7.9dB	4.8dB	4.3dB	3.5dB	2.9dB	2.6dB

Use CH0 for both signal out and reflection in
“**Time Domain Reflectometry**” ==> distance = velocity x time
Velocity of RF in cable = velocity factor x speed of light
Measure the **loss** of the return signal (dB) = **cable attenuation**

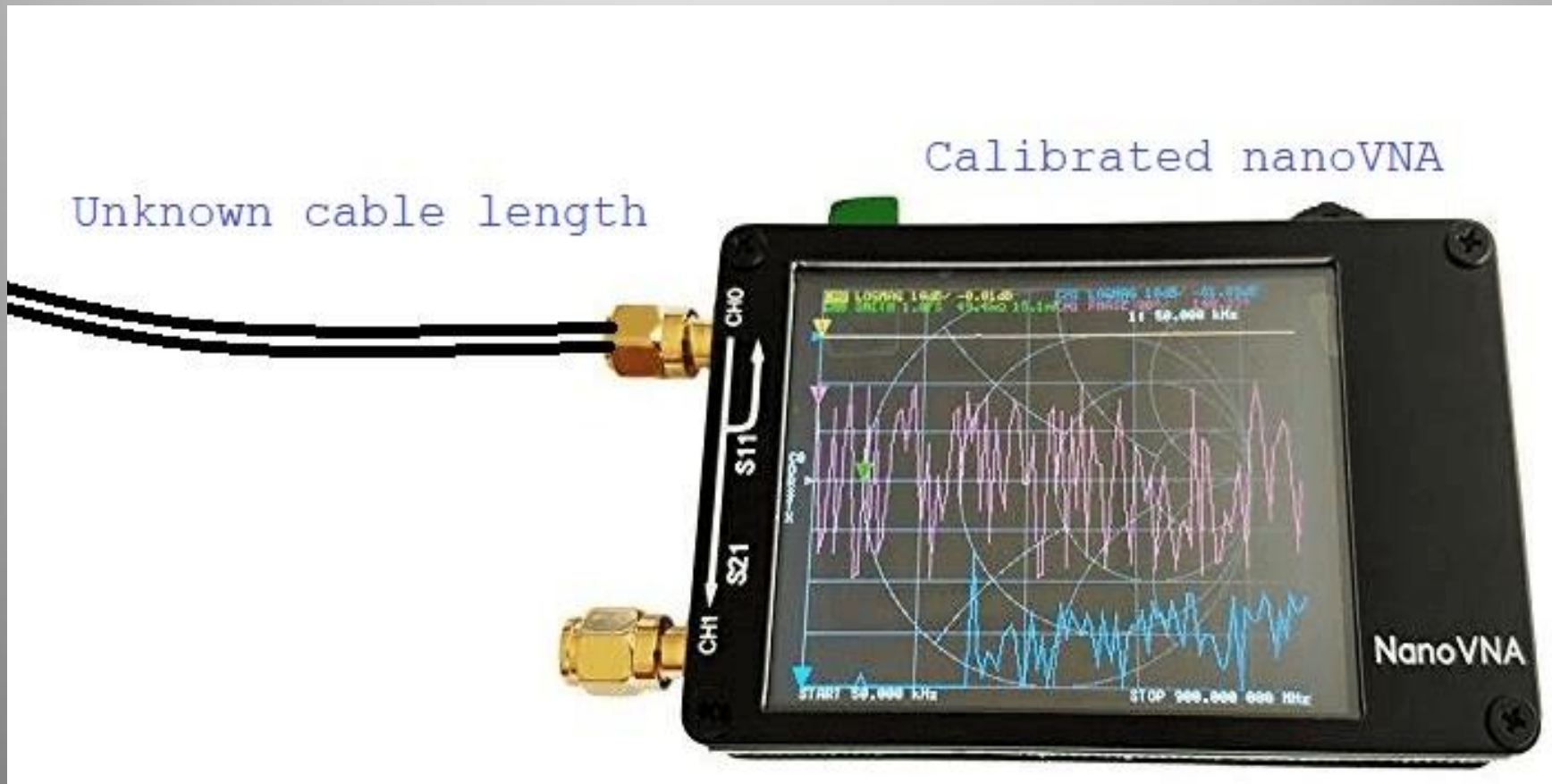

HOW TO: Measure Length of unknown coax cable

Connect a cable that converts SMA to SO239 (coax female)

Calibrate the Nano VNA first, then SAVE CALIB file

Connect an unknown length of RG8X coax to Ch0 via a PL259 plug

Short out the “far” end of the 50 ohm RG8X coax

Set the FREQ sweep from 1 MHz to 100 MHz

Set the TDR display function to ON

What “should happen”

When the RF gets to the shorted end of the coax, impedance = 0

100% of the RF should reflect back to Ch0 (SWR is infinite)

TDR display: Belden RG8X cable (VF = 0.82)

An impedance “bump” appears 17.1 meters: WHY?

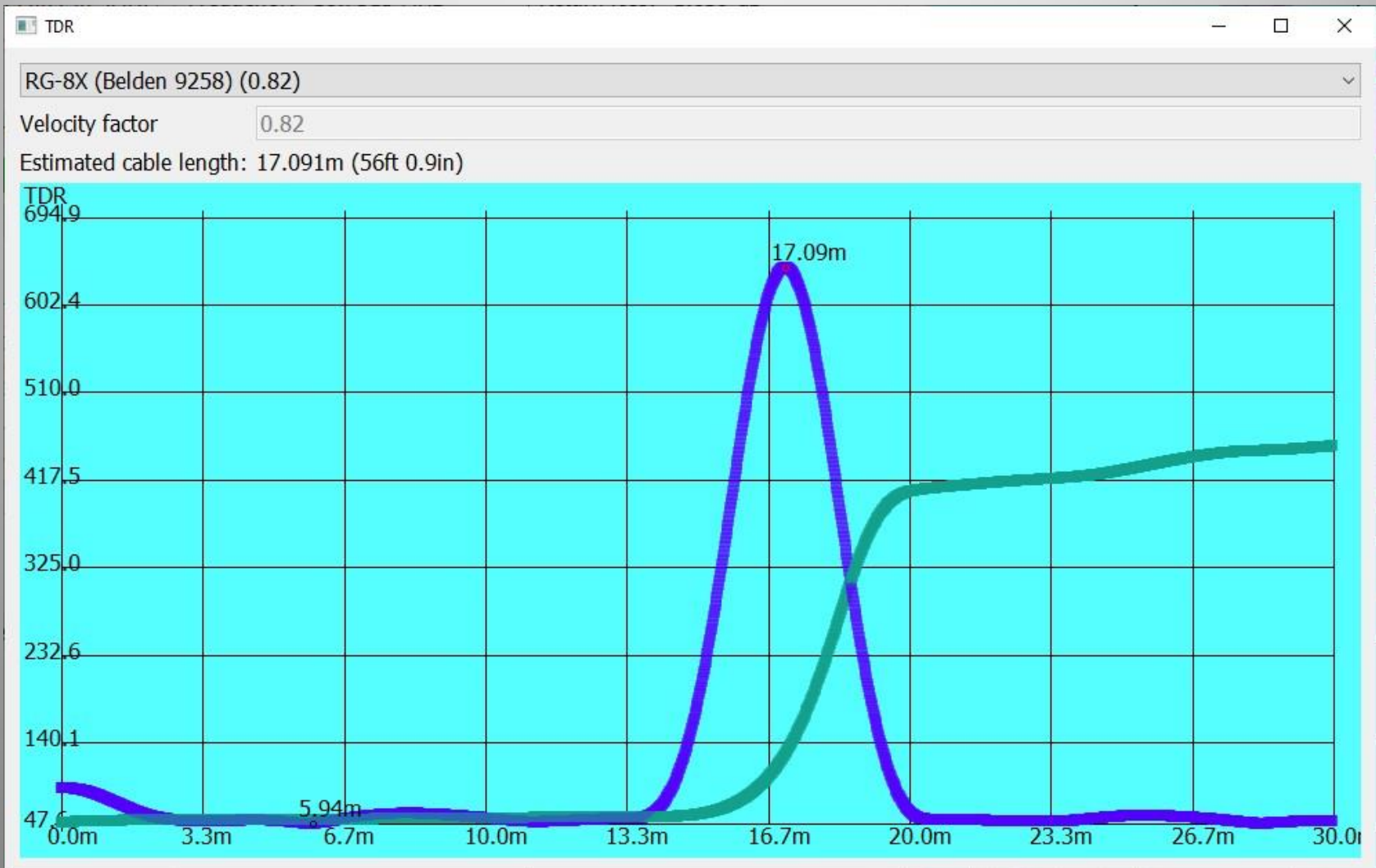

Attenuation (dB) of 50 ft **RG8X** vs. Frequency (1-100 MHz)

At what frequency is the “heat” loss = 50% of the power?

Why does the attenuation increase with frequency?

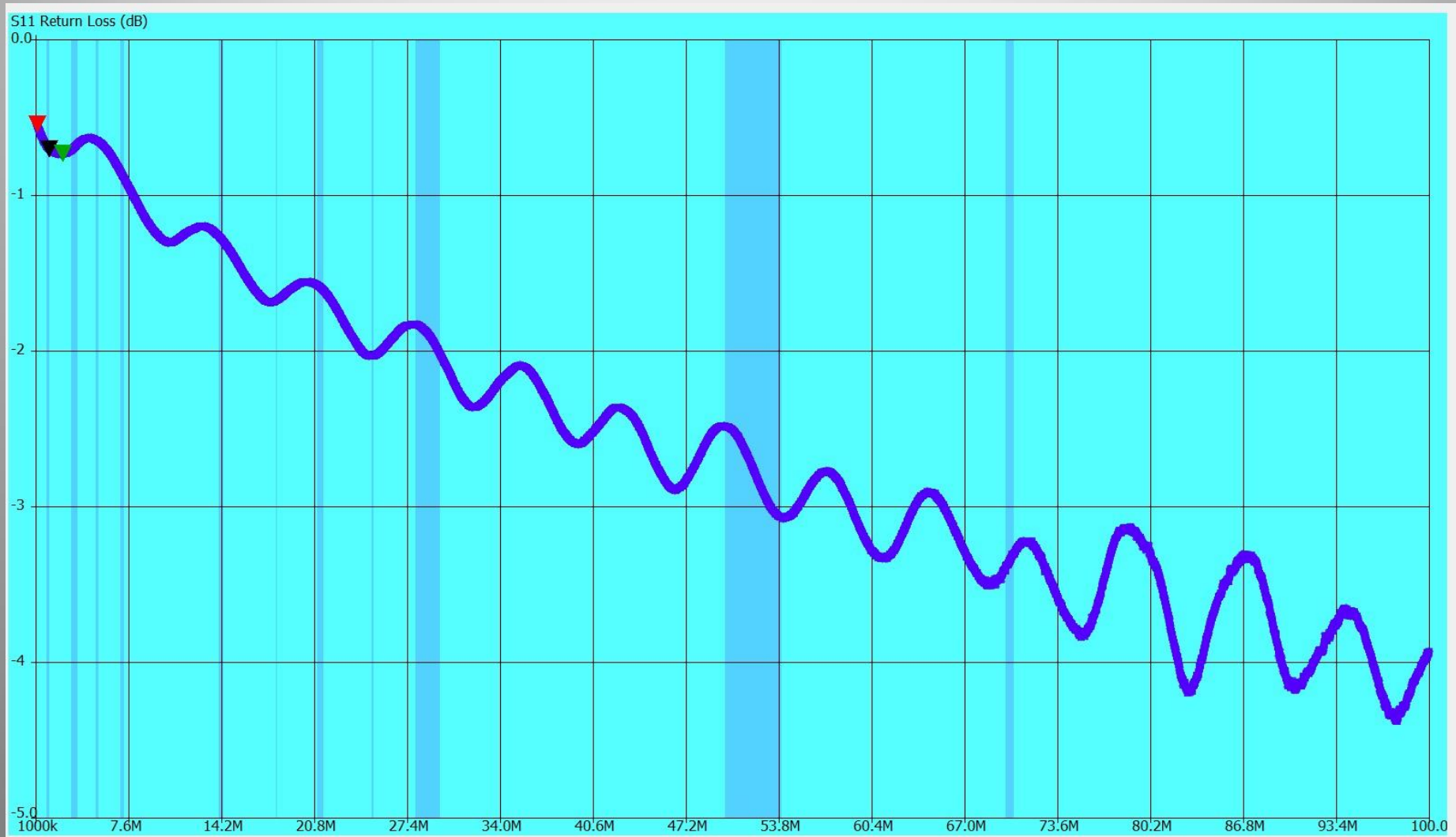

dB LOSS AT FREQUENCY

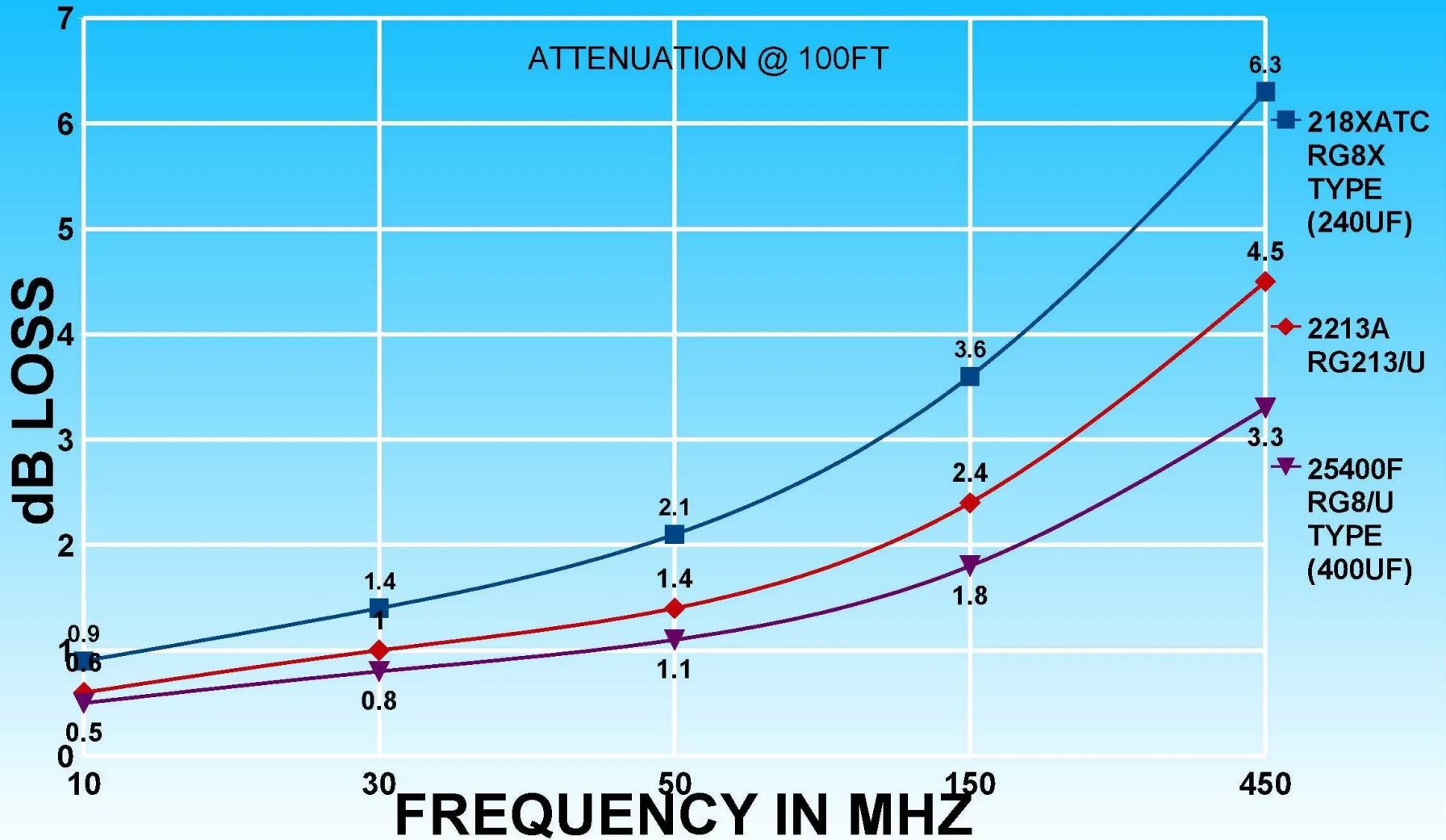

Measure the frequency response of a LC filter by measuring the “THRU” response: Ch0 to Ch1

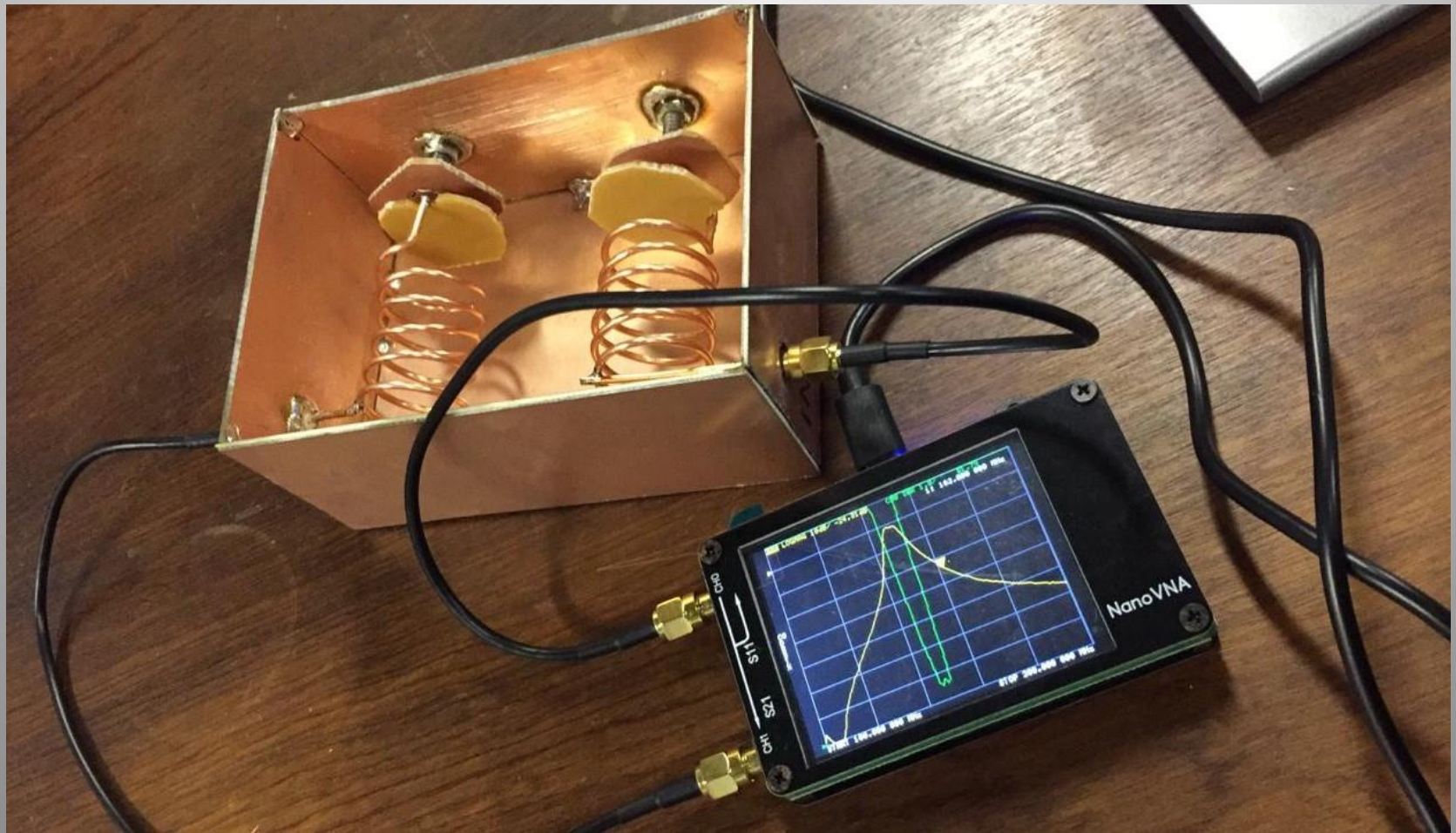

Help to adjust a manual ANTENNA TUNER
Where on the Smith Chart do you “want” the cursor?



Advanced: measure trap Q by use of TWO Channels



A FM broadcast band-stop “filter”

Use the S21 mode (two ports)

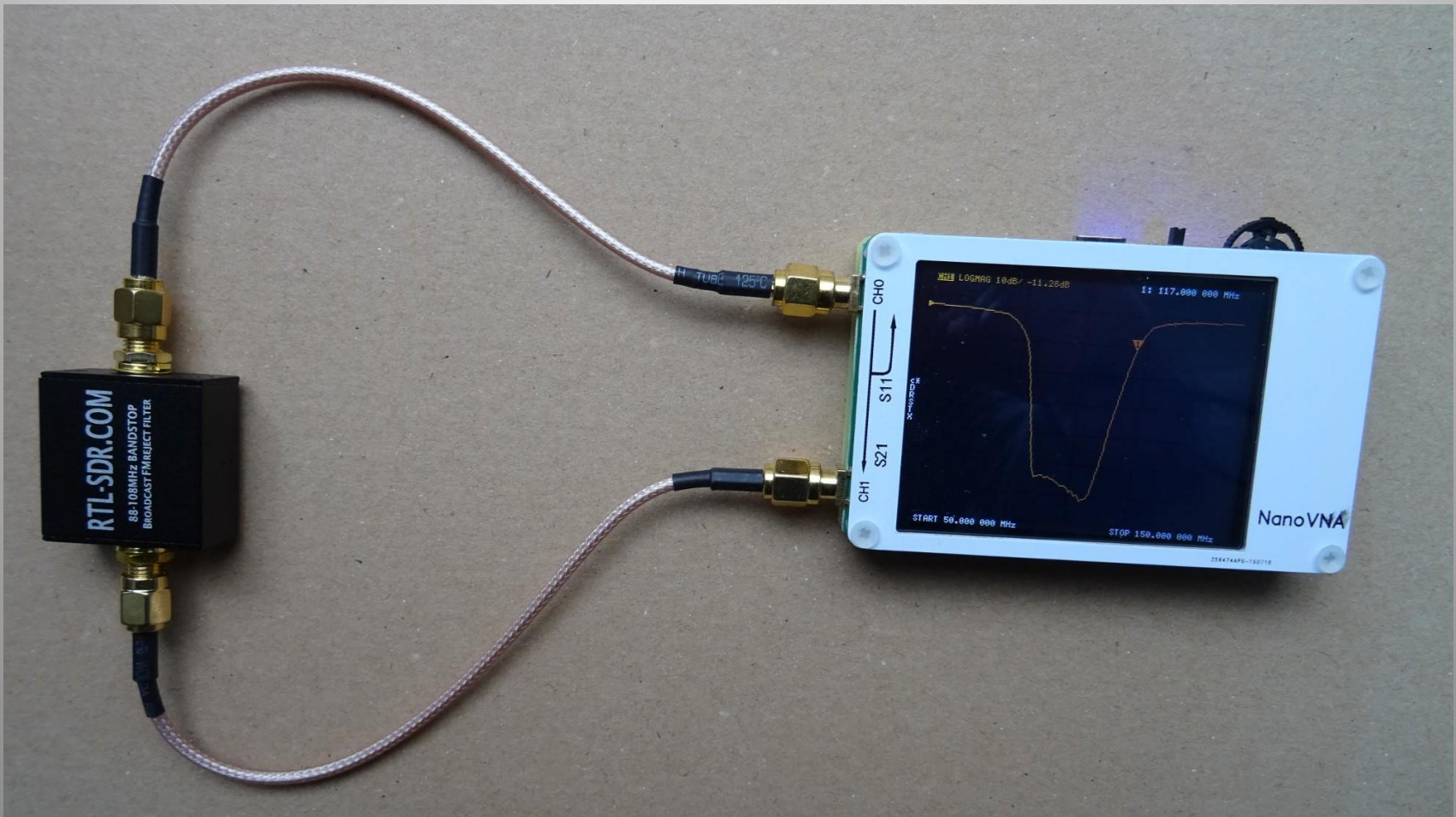

A Great Teaching Tool !

